

By A. R. Winstanley

THE DEVICE to be described here is designed to generate an audible tone after a predetermined delay. The delay period can be adjusted between approximately three seconds and one hundred seconds, but much longer delays can be obtained by experimenting with component values.

Suggested uses include its utilisation in children's games as a "time up" buzzer, or possibly delayed action burglar alarms. The photographer will also find it most useful.

CIRCUIT DESCRIPTION

The circuit diagram is shown in Fig. 1. Transistor TR1 is a special type of transistor called a "unijunction transistor". In this circuit it is normally off, that is, there is a very high resistance between base 2 and base 1.

Capacitor C1 is a large electrolytic capacitor which charges up slowly through VR1 (a variable resistor) and R1, until the potential at the emitter of TR1 is approximately 5.5V.

At this point the unijunction transistor rapidly switches over and C1 is able to discharge through the transistor and R3 to ground. The electrolytic capacitor will then recharge and the whole process is repeated until the power supply is removed from the circuit.

Note that by adjusting C1, R1 or VR1, different time delays can be achieved.

TRIGGER PULSE

The positive discharge pulse at base 1 of TR1 is transmitted by C2 to the gate of CSR1. This device is a controlled silicon rectifier or "thyristor" and normally a very high resistance exists between anode (a) and cathode (k). Once however, a suitable pulse is received at the gate terminal (g), the thyristor will rapidly trigger and the anode to cathode resistance falls to a very low value. The circuit to WD1, a miniature audible warning device consuming only 15mA, is therefore completed and the buzzer operates.

A thyristor will remain in this conductive state once a pulse is transmitted to its gate. It can be reset by removing the power supply or reducing the anode/cathode current to a very low value. Resistor R4 is included in the anode circuit to ensure that a minimum holding current is always flowing when the c.s.r. is conductive, therefore preventing it from resetting undesirably.

The audible warning device could be replaced with a visual indicator but the load must not exceed the forward current rating of the thyristor (500mA) and due attention should be paid to the capacity of the PP3 battery from which the circuit operates.

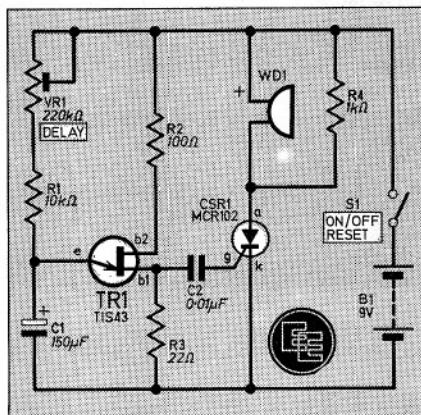

Fig. 1. Circuit diagram of the Time Delay Indicator.

CONSTRUCTION

The circuit is housed in a Bimbox, type BIM2003/13 plastic box measuring 112 x 62 x 31mm, although any similar size case can be used. The circuit itself is built onto a small piece of 0.1 inch stripboard measuring 23 holes by 9 strips as shown in Fig. 2. This is trimmed from the standard 10 strips x 24 holes stripboard and enables the circuit board to be retained in the p.c. guides moulded into the interior of the plastic case.

Construction is quite straightforward. The only points to watch are correct orientation of the transistor and thyristor leads. Also make sure you connect the electrolytic capacitor and audible warning device the right

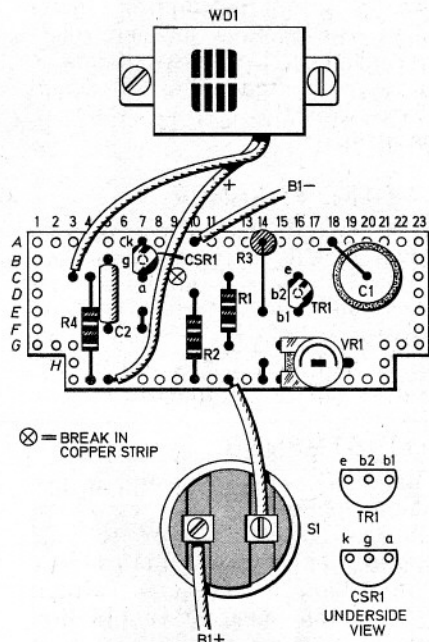

Fig. 2. Complete wiring details for the unit. Note that if you are using the Free piece of stripboard with this issue, one strip and a column of holes need to be removed. This is to allow the board to be vertically mounted within the specified case, using the fixing slots. Also note the two cut-outs and one break to be made.

COMPONENTS

Resistors

- R1 10k Ω
- R2 100 Ω
- R3 22 Ω
- R4 1k Ω
- All $\frac{1}{4}$ W
- carbon $\pm 5\%$

See
**Shop
Talk**
page 144

Potentiometer

- VR1 220k Ω miniature horizontal preset

Capacitors

- C1 150 μ F 10V elect.
- C2 0.01 μ F polyester

Semiconductors

- TR1 TIS43 n-channel unijunction transistor
- CSR1 MCR102 or similar thyristor (0.5A 30V)

Miscellaneous

- WD1 9V 15mA audible warning device (Maplin)
- S1 s.p.s.t. "Hekla" rocker switch (Maplin)
- B1 9V PP3 battery
- Stripboard: 0.1 inch matrix 9 strips x 23 holes; plastic case: Bimbox type BIM2003/13 blue or similar 112 x 62 x 31mm; battery clip to suit B1; lettering as required; connecting wire.

Approx cost—Guidance only
£2.50 excluding case

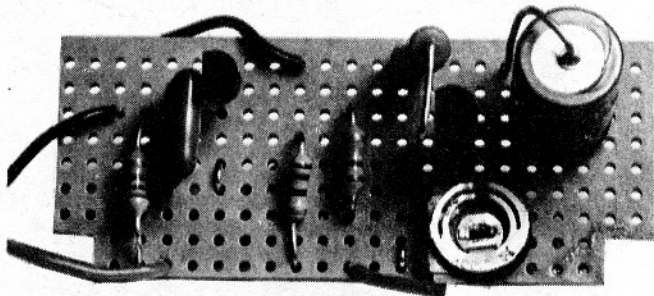

The completed circuit board showing layout of components. Note the two small link wires. If you use the specified case and the stripboard given Free with this issue you must remove one strip and a row of holes, and cut the corners as shown. This allows the Ild to hold the board in place

way round. Finally do not overheat the semiconductors (TR1 and CSR1) in the soldering process. A heatshunt is advised for this process.

Drill the case as necessary to take the switch and buzzer. The latter item is mounted on the exterior of the case using two 8BA bolts. Complete the

unit and arrange the internally-retained components to conform with the overall arrangement used in the prototype unit.

The case could be lettered if desired; use rub-down lettering and then give the case a light coat or two of clear aerosol lacquer. This should all be done just after the case has been drilled.

The battery can be retained using double sided adhesive foam strips.

Once constructed, set the preset resistor to give the desired delay before the alarm sounds. The device is then complete and ready for use. ☒

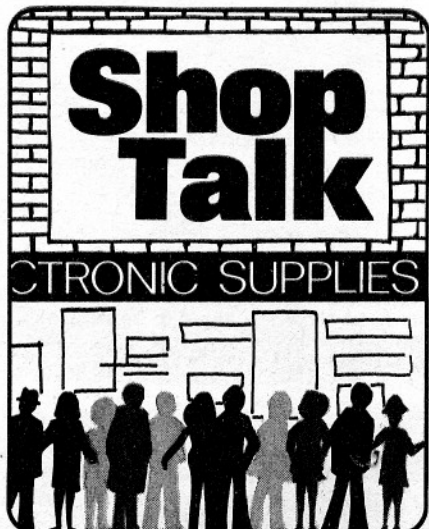

By Dave Barrington

CONSTRUCTIONAL PROJECTS

Just a look at the list of this month's construction projects should send most readers rushing for their soldering irons.

Time Delay Indicator

For the *Time Delay Indicator* a thyristor type MCR102 is called for and could prove a problem. However, this should be available from Maplin. Also, any other type which requires a 0.8V at 0.2mA gate trigger signal will be suitable.

The audible warning device and switch is available from many of our advertisers. An alternative warning device is obtainable from Progressive Radio, 31 Cheapside, Liverpool, L2 2DY, price 78p (postage extra). Specify the 9V version. The Bleeptone from Home Radio or the Mini-Bleeptone from Verospeed (£3.80 plus VAT) are also suitable types.

Direction Indicator

One or two points need to be made regarding the *Direction Indicator*. The transistor type 2N4060 may be difficult to obtain, but is listed by Maplin Electronic in their catalogue. Also, the 2N4061 or 2N4062 may be used for TR3.

The relay specified does not necessarily have to have four sets of contacts, they must however be change-over types, as three sets of contacts are wired in parallel merely to be on the safe side when carrying the large currents required by the indicators. Any other relay, provided it can handle the current requirements, with at least two sets of changeover contacts can be used.

When incorporating the "Hazard Flasher" modification, a heavy duty relay is specified. This relay replaces the existing one only if the original cannot handle the increased current.

One Transistor Radio

There should be no problems with components for the *One Transistor Radio*, but some readers may experience difficulty in locating the Dilecon 300pF variable capacitor Cl. Maplin, Watford, Home Radio, Greenweld are just four of our advertisers who should be able to supply.

Versatile Power Supply

The only item that could be troublesome in the *Versatile Power Supply*, this month's *Mini Module* project, is likely to be the mains transformer. This transformer calls for a 9V-0-9V secondary and many of our advertisers should be able to supply an equivalent.

2020 Tuner Amplifier

This month we get to grips with the hardware for the *2020 Tuner Amplifier*. The cord drive assembly for the radio section is available from Maplin Electronics.

For those readers who are not too keen on doing their own metal bending a kit of undrilled metal work is available from Kitson's Sheet Metal Ltd., It may be possible that readers can

make arrangements with their local stockists who may be prepared to do the necessary bending.

Labcentre

Our major constructional article this month is the *EE Labcentre* and we are sure it will appeal to both the professional and amateur alike. Provided details are followed carefully it should not present any difficulties in construction and only a few components warrant further mention.

The "executive" type briefcase used to house the electronics and tools is, of course, arbitrary and readers may use any suitable housing of their own choice. The "test bed" or breadboarding strip used in the prototype was of American origin but there are now many alternative types available from advertisers which would be suitable.

We found that the Super Strip SS2 from Lektrokit Ltd. London Road, Reading, Berks. RG6 1AZ is identical to the original at a cost of £11.50 including postage. The SS2 is also available from Maplin, Watford and Marshalls.

Should the mains switch with built-in neon prove troublesome to obtain it can be replaced with a standard mains switch and a separate mains neon indicator.

As the *Labcentre* is going to see regular service we suggest readers use a good quality printed circuit board for this project. If readers do not feel capable of making their own board they can be purchased from C.C. Consultants, 77 St. Marks Road, Worle, Weston-Super-Mare, Avon BS22 0HN, who hold the copyright for the p.c.b. design. The cost is £4.85 including postage.

Components Sale!

We understand that in readiness for their move to new premises shortly, Home Radio are going to offer drastic price reduction on certain components. Items being offered are new stock surplus to current catalogue.

This offer is to personal shoppers only at their current address from March 24 to 31.