

Stuck In the Sixties: Power Grid Modernization Remains Elusive

Mark Sardella, PE Santa Fe, New Mexico USA

Nearly half of all electricity generated in the world today comes from power plants that use steam turbines built in the days of rotary telephones and manual typewriters, operating at thermal efficiencies of around thirty-percent and thereby discarding seventy percent of the energy in the fuel they consume.

How did the electric power industry miss out on the technological revolution of the past 50-years, and what can be done to bring the industry in-line with telecommunications, transportation, computing and countless other industries that have evolved so dramatically over the same time frame?



A phone built in 1968, compared to a typical phone in use today.



A coal-fired power plant built in 1968, compared to a typical coal-fired power plant in use today.

The key to power grid evolution begins with removing the barriers that hinder it, followed by laying the organizational and regulatory foundation on which evolution can flourish. Power networks are complex systems, and as such they can be guided, using appropriate ownership models, incentives and policies, to self-organize into highly beneficial and adaptive states.

Power Grid Evolution

It is helpful to know what the evolution of the power grid might look like, and since a couple of regions around the globe have evolved grids, we have a window through which to see the future.

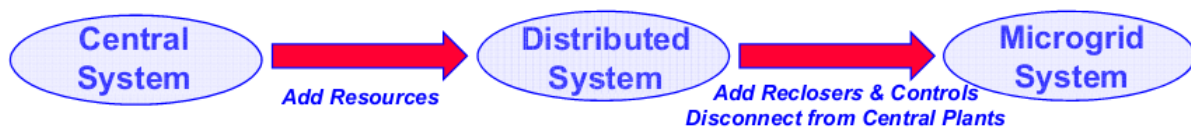

The most obvious characteristic of evolved grids is that they are decentralized. The typical way the decentralization process begins is by connecting additional generators to the grid, including solar and wind but preferably including a wider array of technologies. The next step in decentralization is connecting other types of resources to the grid, including controllable loads and energy storage systems, such as batteries. All three types of resources to be added – generation, storage and controllable loads – should be diverse in size and technology and should be dispersed widely throughout the network.

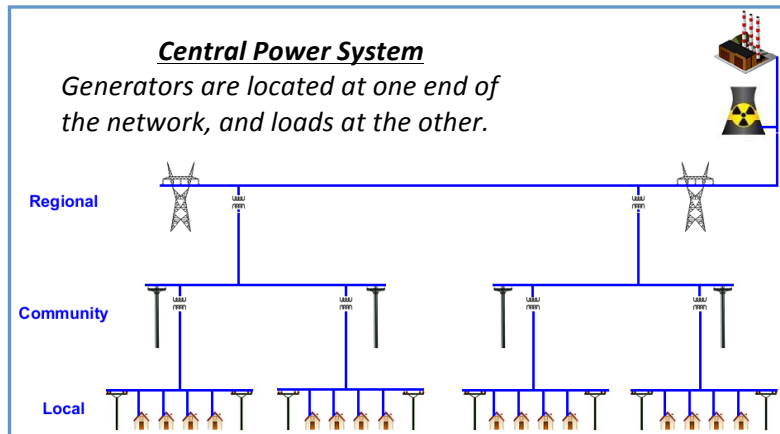

Decentralized power networks are considered an evolutionary step forward because they are more

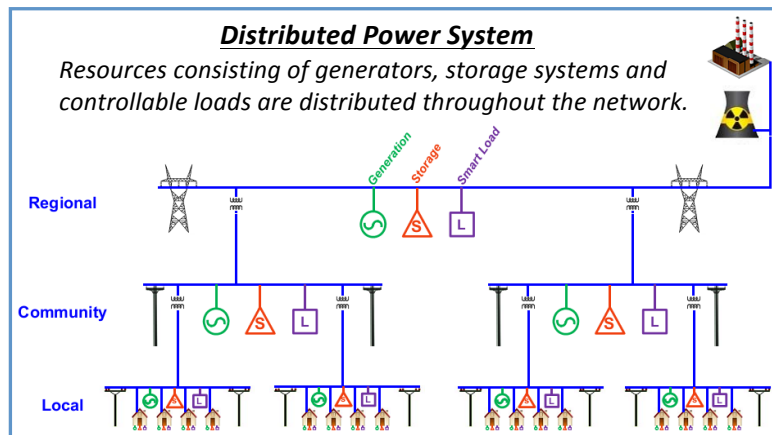

diverse, more complex and they bring significant advantages. Distributed power systems are less reliant on the large, central power stations that are so inefficient, and they reduce reliance on expensive, long-haul transmission lines. Diversifying the energy supply opens electricity markets to new players, and makes the grid less vulnerable to problems that arise with any single generation

technology. And distributed grids are more easily expandable, because increased loads can often be served by simply adding new generators rather than upgrading power lines.

The next evolutionary step beyond distributed electric systems is microgrid systems. Microgrids are decentralized power networks that have been strategically populated with distributed resources to the point that they are able to operate without central power stations. They have the ability to interconnect with other power grids, but they disconnect automatically whenever it is beneficial to do so, such as when the other grid experiences an outage. When disconnected (or “islanded”) from other grids, microgrids rely solely on their own resources – generators, storage systems

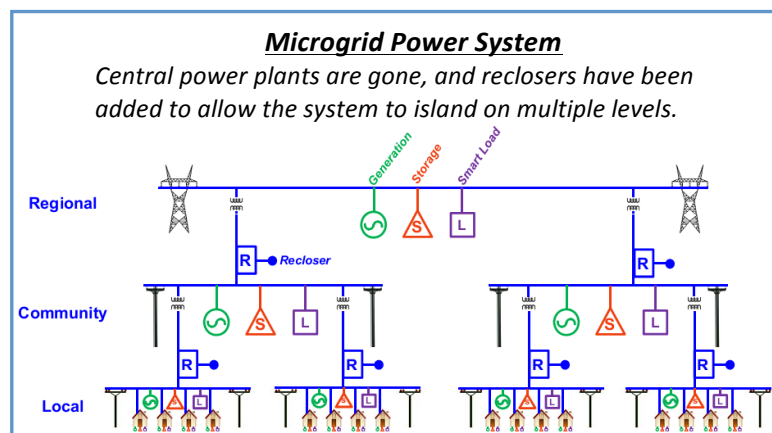

and controllable loads – which work together to maintain stable conditions on the grid and a balance between electricity supply and demand.

Moving from distributed systems to microgrid systems is especially significant because it enables local self-reliance in electricity. Once a region is no longer reliant on an outside power supplier, an entirely different relationship forms between the region and its former electric supplier, putting the region in a much stronger negotiating position and making it far less vulnerable to outside influences.

Policy Drives Evolution

Most technological evolutions are driven by innovation and access to capital, but evolution in the electric power sector is predominantly driven by regulation. Privately owned electric utilities are powerful monopolies, especially where regulators allow a single, private company to own both the distribution system and the generation resources. Regulators attempt to reign in the power of such utilities by making rules controlling access to markets and assigning risks and rewards. Regulatory policy, depending on how it is crafted, can either promote or hinder the evolution of electric power systems.

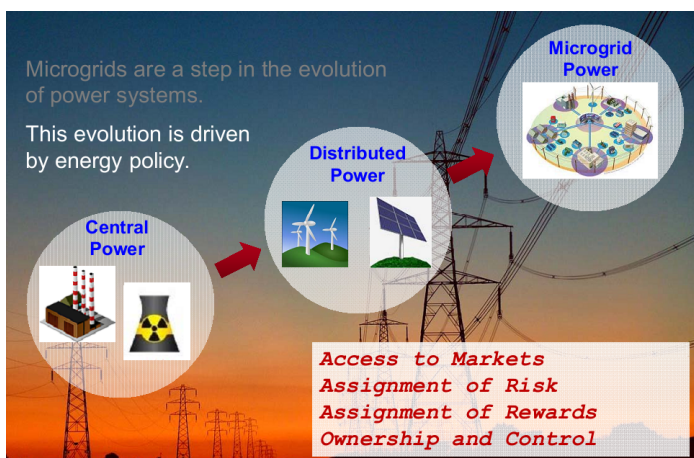

Importance of Power Evolution

Evolved electric power systems, including microgrids, would yield a number important advantages over our current electric systems. First, microgrids lend themselves to newer, smaller generating units that are generally more efficient and less polluting. Given that the U.S. electric power sector releases more than 300 million pounds of toxic air pollution annually, and is responsible for one-third of all U.S. climate-changing emissions, this is a significant benefit.

The network architecture of microgrids gives them outstanding fault tolerance, assuming the connected resources have been selected and installed strategically. Unlike a central power system, in which the loss of a critical generator or transmission line can cause a widespread outage, a well configured microgrid simply breaks itself apart into smaller units when a fault occurs, under a process called “dynamic islanding.” The degree to which connected resources have been selected and strategically located on the grid determines the number of islands that can form. For

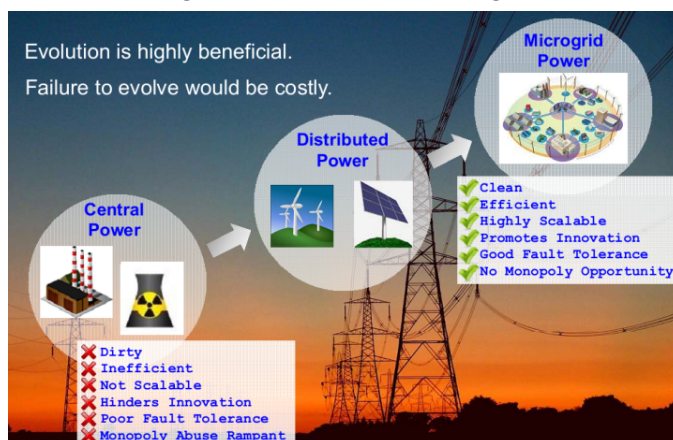

example, given a microgrid system with sufficient generation, storage, and load resources, individual homes could island from their neighborhood power system, the neighborhood system could island from the local power system, and the local system could island from the regional system.

Microgrids also offer significant economic advantages over central power systems. Because microgrids are decentralized, the money spent on electricity from microgrids gets dispersed more widely, creating a more vibrant and robust economy than if the money had been concentrated into a few hands. Further, microgrids lend themselves to local ownership and control, so more energy dollars can stay in the local community, where they are re-spent to create additional, local economic value.

Microgrid systems are not natural monopolies like central power systems, and therefore, so long as ownership and market rules are crafted properly, microgrids should also be less prone to the type of corruption that has plagued central power systems.

Since microgrids are self-reliant energy systems, they are highly desirable for applications in developing regions not currently served with electric power. Implementation of microgrids to promote economic development in remote and insular regions is a focus of the Asia Pacific Economic Cooperation (APEC). But microgrid development need not be limited to remote regions – they are just as applicable and advantageous, and perhaps more easily implemented, in regions served by central-power systems. And, just as the emergence of grid-connected solar systems accelerated the development of photovoltaics technology, the promotion of grid-connected microgrids will greatly hasten the development of technologies and infrastructure to support microgrid development anywhere.

Finally, the best reason to modernize our power systems is that failure to do so could be catastrophic. No other single industry contributes more climate-changing emissions than electric power, and the hour is getting late for addressing carbon emissions. Data from the Arctic shows that the sea ice is melting far faster than predicted by climate models, and extrapolation of the data shows that the Arctic could be ice-free in summer within a decade. Ice reflects sunlight far better

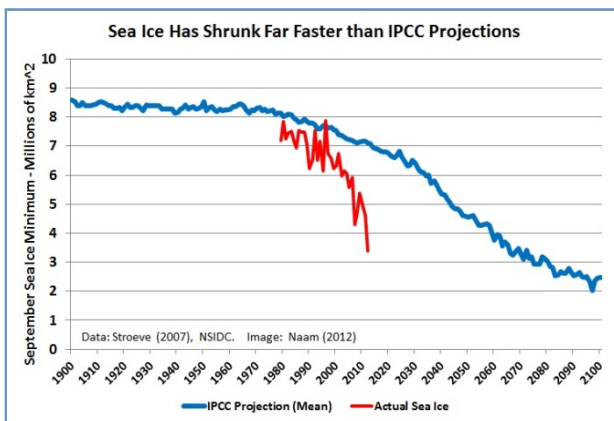
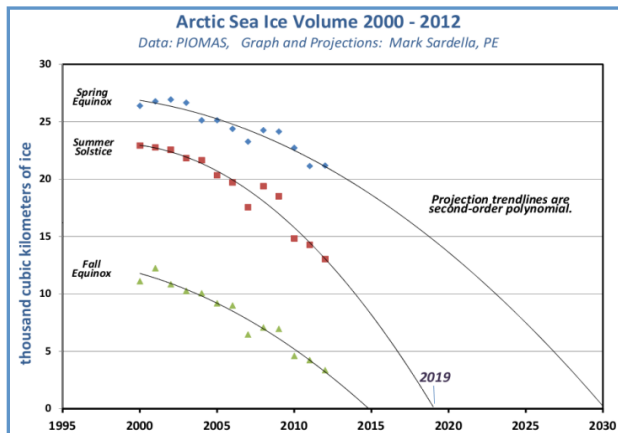

than ocean water, so as more ice melts, the planet absorbs more of the incident sunlight. It is estimated that the loss of summer ice in the Arctic will result in an additional climate forcing as large as the current anthropogenic forcing. Bluntly stated, the rate at which the planet is warming could double in the next seven years unless we move swiftly to cut our emissions.

Regions with Evolved Energy Systems

Denmark is a model for decentralization and self-reliance in energy. In 1973, more than 90 percent of Denmark's energy supply came from imported oil, yet as a result of sweeping reforms, they became energy self-reliant in 1997 and have stayed that way ever since. Today, nearly two-thirds of the homes in Denmark are heated with highly efficient district-heating systems, and about 20 percent of all energy consumed comes from renewable sources. The country is on target to reach their goal of a 30 percent renewable energy supply by 2020.

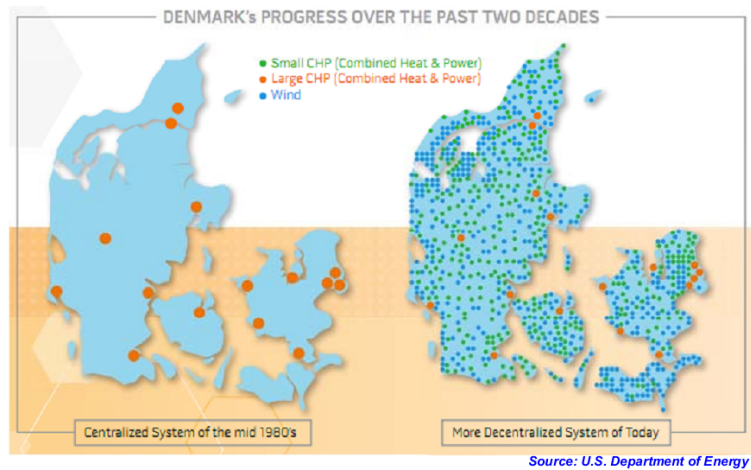

In the electric sector, Denmark not only converted its privately owned transmission network to a public asset, they gave it a new, twofold purpose: ensure that it operates at peak efficiency, and provide all Danish citizens with a right-of-access to generate power in parallel with the grid. Those policies should be the model for the world, especially given their success.

A lesser known success story with energy decentralization is the town of Gussing, Austria. Gussing was nearly bankrupt in 1988 when Peter Vadasz and two of his friends conducted a study to find out how fast money was leaving town to pay for imported energy and fuels. Four years later, Vadasz was elected



mayor on a platform to create jobs by stopping the leakage of energy dollars. By 1996, he had completed the first phase of Gussing's biomass-fired district energy system, fueled by wood waste from a local forestry cooperative. Next, they built the world's most advanced biomass gasifier, and fed the gas to a cogeneration system to generate the town's electricity. Over the next ten years, energy localization was credited with creating more than a thousand jobs, as businesses moved to Gussing to take advantage of the stable, affordable energy costs. The tiny town has cut its carbon footprint by 90 percent, become a major center for renewable energy research, and they now host 30,000 eco-tourists per year.

Policies for Evolving

Based on policies used in regions that have done the best job at decentralizing their energy systems, the following policies are recommended for supporting the evolution of power grids::

✔ ***Operate the network of wires “for benefit” rather than “for profit.”***

Power lines are highways on which electricity travels, and it makes far more sense to travel on publicly owned highways. The network of wires should be treated as essential infrastructure, much like bridges, roads and sewer lines. Don't expect a financial return on the power lines – the benefits come from having a good system in place, not from operating it at a profit.

✔ ***Reward resource providers according to the value they create.***

The most common way to attract independent generators to connect their systems to the power grid is with multi-tier feed-in tariffs (FIT's). Feed-in tariffs are guaranteed-price, long-term contracts for delivery of kilowatt-hours. They are the single most successful renewable energy policy instrument in use today. But even at that, most FIT's don't do all they could to foster value-creation on the power network. Tariff rates should be carefully adjusted to incentivize the resources the network needs most, and to express the values held by the region being served. Clean technologies, or ones that use plentiful, local resources might receive greater rewards, for example. If the system needs firm capacity at a certain time or at a particular location on the network, the FIT should be crafted to attract those resources to those locations. And the reward system need not be limited to generation – capacity and ancillary service providers should also be rewarded according to the locational or time-based value created by the services they provide.

✔ ***Treat users as valued system resources.***

In the same way that resource-providers are rewarded according to the value they create, users should be charged according to the value of what they consume. Again, the opportunity to express the values held by residents of the region is significant. The rate structure can be highly progressive, such that each user receives a basic amount of energy at little or no cost but pays an increasing price-per-unit as consumption rises. And the use of real-time pricing, which alters the price of energy based on the network load, provides value by enticing users to shift loads to times when electricity is less expensive, thereby reducing the peak load on the system.

Policies That Hinder Evolution

Based on policies in use in the United States that have prevented evolution in the electric power sector, the following must be avoided:

✘ ***Do not allow combined generation/distribution entities that are private and for-profit.***

When the same, private for-profit business is allowed to own both wires and generation, the resulting monopoly has proven too powerful, and regulators have been unable to prevent it from wielding its monopoly power to the detriment of the consumers. All transmission and distribution wires must be publicly owned and operated on a “for-benefit” basis, and the right of all users to interconnect resources to the network must be guaranteed by law.

✘ Do not allow private, for-profit market participants to control access to the market.

Under no condition can access to electricity markets be controlled by a private market participant. This seemingly obvious rule has not been followed in the United States, where for-profit utility companies owning both wires and generation have provisions in law allowing them to disconnect any resource at any time, for any reason, with no recourse by the owner of the resource. This has not entirely stopped installations of distributed resources, but it has limited them to those allowed by private utilities, and utilities retain the right to disconnect any or all connected resources at any time, for any reason.

✘ Do not periodically withdraw public funding assistance for a certain technology.

If public assistance is provided to accelerate a particular technology (and it is questionable whether this is a good idea, since feed-in tariffs may be more strategic), the support must be committed for a known duration, and that duration must be sufficient to carry projects from conception to commercialization.

✘ Do not provide guaranteed returns on capital investments.

Under a policy of guaranteed investment returns, utilities maximized their rewards by building expensive systems, rather than efficient systems. Had returns been based on high fuel-efficiency or low emissions, we would have very different power systems today. Incentives must reward exactly what you want to see.

✘ Do not allow private utilities to negotiate special rates to retain customers.

Back in the 1970's, businesses in the United States that needed heat to carry out a manufacturing process discovered that they could install on-site cogeneration systems, which generate both power and heat, to get their energy at a lower cost than the utility could provide. To stop them from doing it, utilities illegally offered monetary incentives to these customers in exchange for agreements to forego installation of on-site generation. Lawsuits followed, until utilities successfully convinced lawmakers to intervene. The laws that followed, called "load-retention rates," gave utilities the right to negotiate special rates, in secret, as needed to retain their best customers. The rationale for the laws was that all customers benefit when utilities don't lose their best customers. These load-retention laws, still in effect in some parts of the United States, dealt a tremendous blow to the decentralization of electric power.

✘ Do not decouple a utility's revenues from its sales volume.

After years of building and operating electric power systems with incredibly low *production-side* efficiency, electric utilities in the United States were put in charge of *consumption-side* efficiency. Arguing that the consumer-efficiency measures they were advocating were reducing their revenues, utilities successfully lobbied for a policy known as "revenue decoupling." Revenue decoupling ensures that utility revenues remain unchanged as their sales decline. There are many flaws in the logic of arguments supporting revenue decoupling laws, but the main problem with them is that by guaranteeing the revenue streams of incumbent energy providers, the process by which businesses get pushed out of markets as they become obsolete no longer functions. If we had guaranteed the revenues of typewriter-makers, for instance, we would still be paying them today, despite having no use for their products.

The Power Grid, Itself a Complex System, Could Self-Organize

Self-organization is the process by which simple rules give rise to order in complex systems. Most systems exhibit some degree of self-organizing behavior, but depending on the rules governing the system, higher levels of order can emerge. One example is complex adaptive behavior, which enables the elements of a system to respond collectively to changes in circumstances. All successful ecosystems



are complex adaptive systems. The next higher level of order is swarm intelligence, enabling elements of a system to collectively solve problems in ways that individual elements of the system cannot. Honey bees select their new hive location using swarm intelligence.

Can complex-systems theory be applied to the development of electric power systems, as we try to usher them toward more complex, adaptive and intelligent states?

There is reason to believe it can, especially to help solve the problem of optimally populating networks with distributed resources. The electric power network itself is a complex system, but the system we want to optimize includes not only the grid and the resources connected to it – it also includes the businesses and individuals involved in developing new resources for the network.

Experience shows that an important ingredient for rapid technological evolution is providing a **platform** on which to evolve. The network of wires, so long as access is a right rather than a privilege, is that platform. It is also known, based on both theory and experiment, that the rules governing interactions between elements of a system determine the degree of order that will arise. The policies effecting resource developers, and the regulations governing markets and grid operations, are those rules.

The difficulty lies in knowing how to craft rules such that the system becomes populated optimally and ends up with the ordered, intelligent characteristics we are seeking. The power network is complex enough, and the rulemaking options vast enough, that it is surely easier to find an optimal result experimentally than analytically – a characteristic known as being “algorithmically incompressible.”

Fortunately, there are examples of good policymaking leading to evolution. Countries with more evolved power grids have better rules for grid access and, consequently, more entities developing grid resources. Ones that pay a premium for electricity generated by a particular technology excel in development of that technology. But these examples evidence success in reaching goals that are somewhat limited compared to the task at hand. To reach the goal of adding distributed resources in sufficient number and diversity to enable a self-reliant power system to emerge requires a more carefully crafted set of policies.

If policies are to induce power systems to evolve to the point of enabling local self-reliance, as microgrids ultimately do, the policies may need to embody the values held by self-reliant societies. Each country seeking energy self-reliance must identify those values on its own, but examples common to all

of them may include achieving the highest possible efficiency, and providing opportunities for all interested parties to participate in the development of a wide range of locally available, renewable and clean resources. Cooperation among participants may also be a characteristic common to self-reliant societies.

Summary and Conclusions

Microgrids represent an evolved state of electric power systems, and so the key to advancing microgrids is to foster the evolution of electric power systems. Because microgrids are self-reliant power systems, they are attractive for remote regions not yet served by electricity, but microgrid development may progress more quickly with a focus that begins with upgrading existing, centralized power systems.

The evolution of power systems begins with populating existing grids with high levels of distributed resources. When this is done strategically, the resulting system will take on beneficial characteristics, such as being diverse, clean, reliable and fault tolerant, and yielding local economic benefits and opportunities. Fully optimized, power systems can be operated as islands, providing the most desirable characteristic of all – local self-reliance in electricity.

Complex systems theory suggests that achieving an optimal result from decentralization requires a platform on which the grid can evolve, and a well crafted set of policies and practices. It furthermore lends insight into the direct role that policies and practices play in the degree of order obtained in the result, including how strongly the values embodied in the rules may be expressed in the power system created under those rules. Determining what policies will be needed to help power systems evolve to a state so ordered that they provide local self-reliance begins with identification of the values of self-reliant societies, followed by ensuring that those values are expressed throughout the policies.

Because values are so strongly expressed in electric power-systems, energy policymaking carries enormous responsibility. Energy policy provides one of very few opportunities to make an enormous difference in the quality of people's lives, the health of their environment, and the vibrancy of their economy. Enabling energy self-reliance, including by advancing the evolution of central power systems to distributed power systems and then to microgrids, is a tremendous way to honor that responsibility.