

TROLLTUNE CORPORATION
2710 Thomas Avenue
Cheyenne, WY 82001

SUPPLEMENT NO. SFM7504-SW-R

FAA APPROVED

SUPPLEMENTAL AIRPLANE FLIGHT MANUAL

FOR

CESSNA 182Q s/n 18265176 through 18266590 and s/n 18263479

STC SA03608AT Maximum Gross Takeoff Weight Increase

Registration No. _____

Serial No. _____

This supplement must be used in conjunction with existing placards and material required to be furnished to the pilot under CAR Part 3 (as found in Cessna Pilot's Operating Handbook for the 1977 and 1978 model years) whenever this aircraft is operated at weights above 2950 lbs. in accordance with Trolltune Corporation FAA STC SA03608AT or EASA STC 10026913. The information contained in this document supplements or supersedes the Pilot's Operating Handbook or placards only in those areas listed. For limitations, procedures and performance information not contained in this supplement, consult the basic Pilot's Operating Handbook, markings and operating placards.

FAA Approved

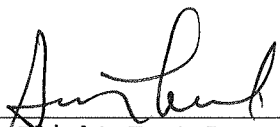

Manager, Flight Test Branch, ANM-160L
Federal Aviation Administration
Los Angeles Aircraft Certification Office
Transport Airplane Directorate

Date:

Aug 13, 2011

SUPPLEMENT NO. SFM7504-SW-R

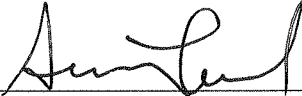
RECORD OF REVISIONS

Rev No.	Page No.	Date	Description	FAA Approved
I/R	All 1-22	22/08/2008	Maximum Takeoff Gross Weight Increase to 3100 lbs. Initial Release	David Crew Manager, Flight Test Branch Federal Aviation Administration Atlanta Aircraft Certification Office Date: <u>22-August-2008</u>
1	1	13/05/2011	Added reference to EASA STC and changed FAA approval block and approval date.	 Manager, Flight Test Branch, ANM-160L Federal Aviation Administration Los Angeles Aircraft Certification office Transport Airplane Directorate Date: <u>5/13/2011</u>
	2	13/05/2011	Added Record of Revision page.	
	3	13/05/2011	Added performance and limitations note.	
	5	13/05/2011	Added limitation statement.	
	1-25	13/05/2011	Reformatted and incremented pages numbers.	

SUPPLEMENT NO. SFM7504-SW-R

SECTION 1 - GENERAL

NOTE: Changes in loadings, limitations, airspeeds, and other performance data due to the gross weight increase described in this SAFM were developed based upon the original airplane configuration as found in the basic Cessna Pilot's Operating Handbook (POH) and approved placards. If other STCs (e.g., autopilot, aux fuel tanks, engine upgrades, etc.) have been incorporated, it is possible that their associated flight manual supplements describe different limitations or performance data from that shown here.

MAXIMUM CERTIFICATED WEIGHTS:

Maximum Ramp Weight: 3110 lbs.
Maximum Gross Takeoff Weight: 3100 lbs.
Maximum Landing Weight: 2950 lbs.

SPECIFIC LOADINGS:

Wing Loading: 17.8 lbs./sq. ft.
Power Loading: 13.5 lbs./hp.

SUPPLEMENT NO. SFM7504-SW-R

SECTION 1 - GENERAL (continued)

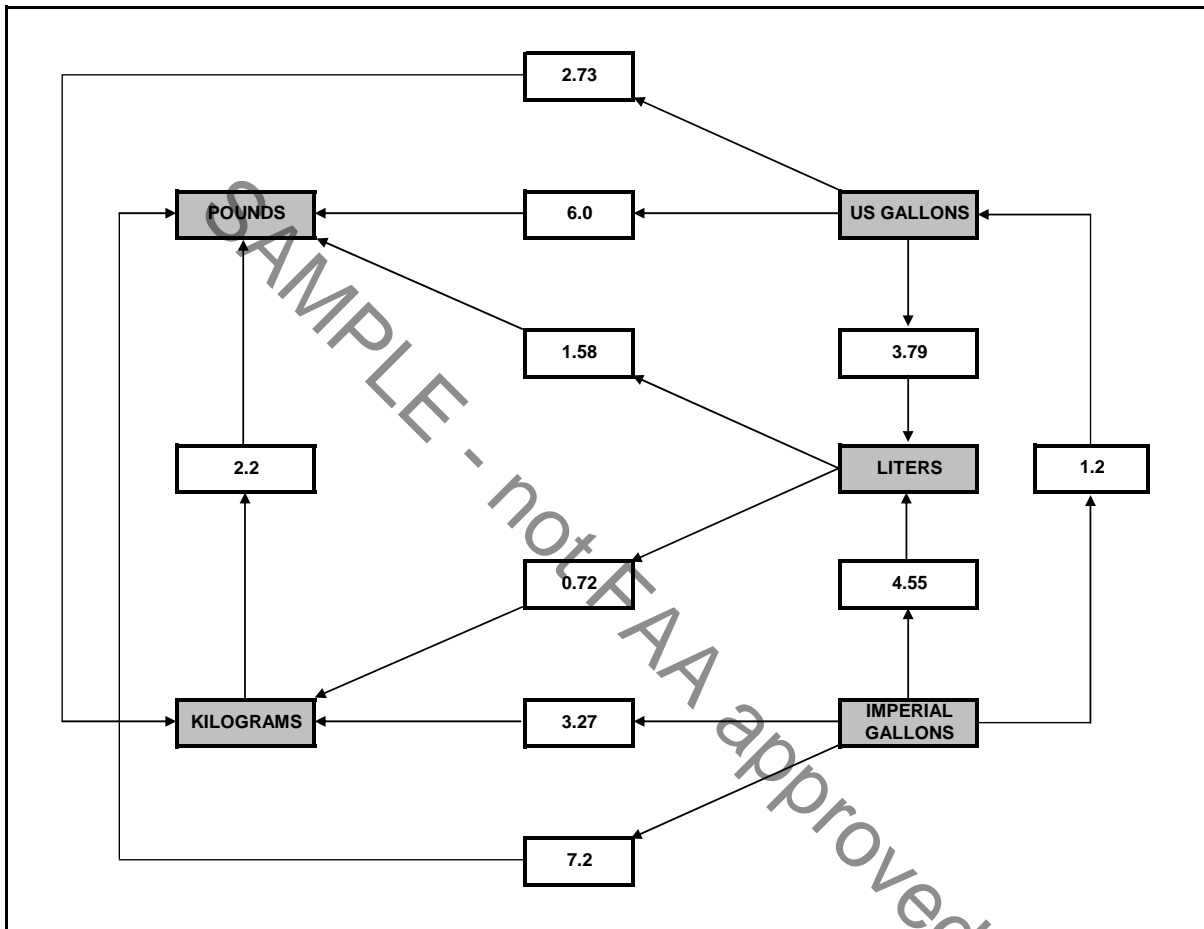

Metric / Imperial / US Units Conversion Chart

SUPPLEMENT NO. SFM7504-SW-R

SECTION 2 - LIMITATIONS

The limitations in this section may be further restricted by other installed STC(s), FAA Form 337, associated AFMS(s), or SAFM(s).

WEIGHT LIMITS:

Maximum Ramp Weight: 3110 lbs.
Maximum Takeoff Weight: 3100 lbs.
Maximum Landing Weight: 2950 lbs.

A normal start, taxi and run-up time of ten minutes will consume approximately 10 lbs. of fuel. Normal landings must not be made at weights in excess of 2950 lbs. For a typical 3100 lbs. takeoff, climb, and cruise profile, this equates to a minimum flight duration of approximately one hour and forty-five minutes.

CENTER OF GRAVITY LIMITS:

Forward: 33.0 inches aft of datum at 2250 lbs. or less, with straight line variation to 40.9 inches aft of datum at 3100 lbs.
Aft: 48.5 inches aft of datum at all weights except 46.0 inches aft of datum at weights above 2950 lbs. to 3100 lbs.

SECTION 3 - EMERGENCY PROCEDURES

AIRSPEEDS FOR EMERGENCY OPERATION:

ENGINE FAILURE AFTER TAKEOFF, 3100 LBS:

Wing Flaps Up: 75 KIAS
Wing Flaps Down: 70 KIAS

MANEUVERING SPEED:

3100 lbs.: 111 KIAS

MAXIMUM GLIDE:

3100 lbs.: 76 KIAS

PRECAUTIONARY LANDING WITH ENGINE POWER:

3100 lbs 70 KIAS

LANDING WITHOUT ENGINE POWER, 3100 LBS:

Wing Flaps Up: 75 KIAS
Wing Flaps Down: 70 KIAS

DITCHING WITHOUT ENGINE POWER, 3100 lbs:

Wing Flaps Up: 75 KIAS
Wing Flaps 10 degrees: 70 KIAS

SUPPLEMENT NO. SFM7504-SW-R

SECTION 3 - EMERGENCY PROCEDURES (continued)

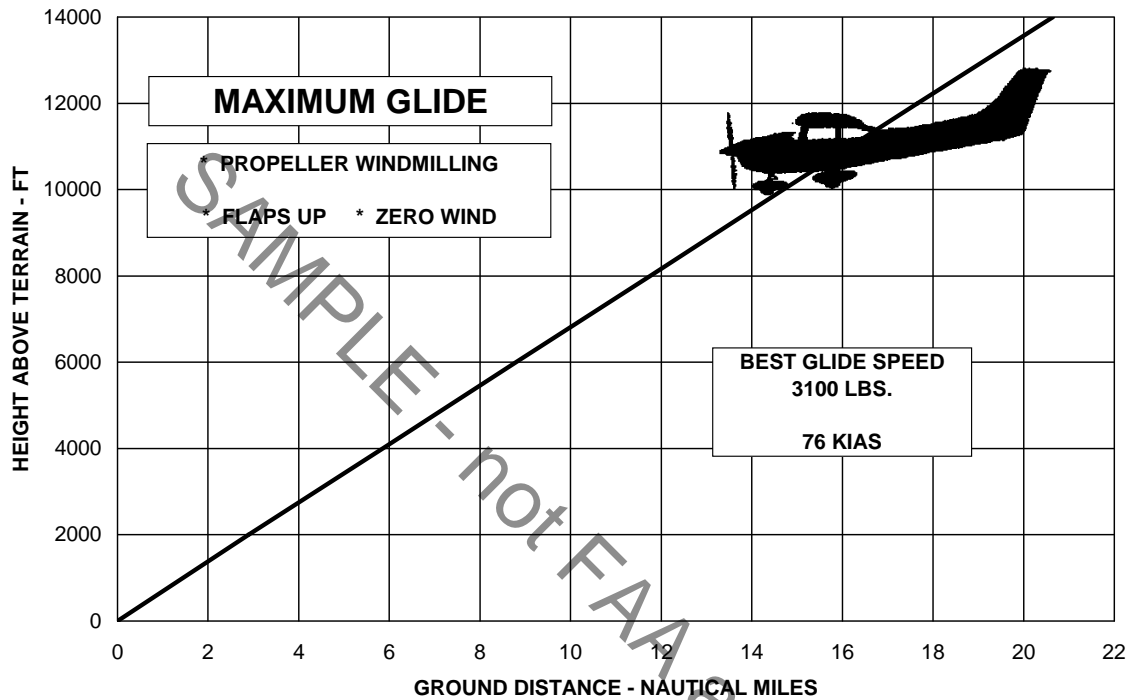

SUPPLEMENT NO. SFM7504-SW-R

SECTION 4 - NORMAL PROCEDURES

SPEEDS FOR NORMAL OPERATION, 3100 lbs.:

TAKEOFF:

Short Field Takeoff, Flaps 20°, Speed at 50 Feet: 59 KIAS

ENROUTE CLIMB. FLAPS UP:

Best Rate of Climb, Sea Level: 81 KIAS

Best Rate of Climb, 10,000 Feet: 75 KIAS

Best Angle of Climb, Sea Level: 59 KIAS

Best Angle of Climb, 10,000 Feet 66 KIAS

MAXIMUM RECOMMENDED TURBULENT AIR PENETRATION SPEED:

3100 lbs.: 111 KIAS

MAXIMUM DEMONSTRATED CROSSWIND VELOCITY:

Takeoff or Landing 15 KNOTS

NOISE ABATEMENT:

The certificated noise level for the Model 182Q at 3100 pounds maximum weight is 79.5 dB(A), determined according to Appendix G of 14 CFR Part 36 through Amendment 28. No determination has been made by the Federal Aviation Administration that the noise levels of this airplane are or should be acceptable or unacceptable for operation at, into, or out of, any airport.

SUPPLEMENT NO. SFM7504-SW-R

SECTION 5 - PERFORMANCE

Refer to the following performance charts for operations at weights above 2950 lbs. to 3100 lbs.:

STALL SPEEDS

CONDITIONS:
 Power Off

NOTES:

1. Maximum altitude loss during a stall recovery may be as much as 250 feet.
2. KIAS values are approximate

MOST REARWARD CENTER OF GRAVITY

WEIGHT (LBS)	FLAP DEFLECTION	ANGLE OF BANK							
		0°		30°		45°		60°	
		KIAS	KCAS	KIAS	KCAS	KIAS	KCAS	KIAS	KCAS
3100	UP	44	58	50	63	58	69	73	82
	20°	41	53	46	57	54	63	67	75
	40°	41	52	46	56	53	62	67	74

MOST FORWARD CENTER OF GRAVITY

WEIGHT (LBS)	FLAP DEFLECTION	ANGLE OF BANK							
		0°		30°		45°		60°	
		KIAS	KCAS	KIAS	KCAS	KIAS	KCAS	KIAS	KCAS
3100	UP	49	60	55	65	63	71	78	85
	20°	48	56	53	60	60	66	73	79
	40°	46	55	51	59	58	65	71	77

SUPPLEMENT NO. SFM7504-SW-R

SECTION 5 - PERFORMANCE (continued)

**TAKEOFF DISTANCE
 MAXIMUM WEIGHT 3100 LBS**

SHORT FIELD

CONDITIONS:

Flaps 20°
 2400 RPM, Full Throttle and Mixture Set Prior to
 Brake Release
 Cowl Flaps Open
 Paved, Level, Dry Runway
 Zero Wind

NOTES:

1. Short field technique as specified in Section 4 of the basic Pilot's Operating Handbook.
2. Prior to takeoff from fields above 5000 feet elevation, the mixture should be leaned to give maximum power in a full throttle, static runup.
3. Decrease distances 10% for each 9 knots headwind. For operation with tailwinds up to 10 knots, increase distances by 10% for each 2 knots.
4. Where distance value has been deleted, climb performance after lift-off is less than 150 fpm at takeoff speed.
5. For operation on a dry, grass runway, increase distances by 15% of the "ground roll" figure.

WEIGHT LBS	TAKEOFF SPEED KIAS		PRESS ALT FT	0°C		10°C		20°C		30°C		40°C	
				GRND	TOTAL	GRND	TOTAL	GRND	TOTAL	GRND	TOTAL	GRND	TOTAL
	LIFTOFF	AT 50 FT		ROLL	50 FT OBS	ROLL	50 FT OBS	ROLL	50 FT OBS	ROLL	50 FT OBS	ROLL	50 FT OBS
3100	50	59	S.L.	720	1365	775	1465	835	1570	895	1680	955	1800
			1000	785	1490	845	1600	910	1720	975	1845	1045	1980
			2000	860	1635	925	1760	995	1890	1065	2035	1140	2185
			3000	940	1800	1010	1940	1085	2090	1165	2255	1250	2430
			4000	1025	1990	1105	2150	1190	2320	1275	2510	1370	2715
			5000	1125	2210	1215	2395	1305	2595	1400	2815	1505	3060
			6000	1235	2470	1330	2685	1435	2925	1540	3190	1655	3490
			7000	1360	2780	1465	3040	1580	3330	1700	3665	---	---
			8000	1500	3170	1615	3485	1740	3855	---	---	---	---

SUPPLEMENT NO. SFM7504-SW-R

SECTION 5 - PERFORMANCE (continued)

MAXIMUM RATE OF CLIMB

CONDITIONS:
 Flaps Up
 2400 RPM
 Full Throttle
 Cowl Flaps Open

NOTE:
 Mixture leaned above 5000 feet for smooth engine operation and increased power.

WEIGHT LBS	PRESS ALT FT	CLIMB SPEED KIAS	RATE OF CLIMB - FPM			
			-20° C	0° C	20° C	40° C
3100	S.L.	81	1010	925	845	765
	2000	80	885	805	730	650
	4000	78	760	685	610	540
	6000	77	640	570	495	425
	8000	76	520	450	380	310
	10,000	75	405	335	265	-
	12,000	73	285	220	155	-

SUPPLEMENT NO. SFM7504-SW-R

SECTION 5 - PERFORMANCE (continued)

TIME, FUEL, AND DISTANCE TO CLIMB

MAXIMUM RATE OF CLIMB

CONDITIONS:
 Flaps Up
 2400 RPM
 Full Throttle
 Cowl Flaps Open
 Standard Temperature

- NOTES:
1. Add 1.7 gallons of fuel for engine start, taxi and takeoff allowance.
 2. Mixture may be leaned above 5000 feet for smooth engine operation and increased power.
 3. Increase time, fuel and distance by 10% for each 10° C above standard temperature.
 4. Distances shown are based on zero wind.

WEIGHT LBS	PRESSURE ALTITUDE FT	TEMP °C	CLIMB SPEED KIAS	RATE OF CLIMB FPM	FROM SEA LEVEL		
					TIME MIN	FUEL USED GALLONS	DISTANCE NM
3100	S.L.	15	81	865	0	0	0
	2000	11	80	760	2	0.8	3
	4000	7	78	660	5	1.7	7
	6000	3	77	555	9	2.7	12
	8000	-1	76	455	13	3.9	18
	10,000	-5	75	350	18	5.3	25
	12,000	-9	73	250	25	7.1	36

SUPPLEMENT NO. SFM7504-SW-R

SECTION 5 - PERFORMANCE (continued)

TIME, FUEL, AND DISTANCE TO CLIMB

NORMAL CLIMB - 90 KIAS

CONDITIONS:

Flaps Up
 2400 RPM
 23 Inches Hg or Full Throttle
 Cowl Flaps Open
 Standard Temperature

NOTES:

1. Add 1.7 gallons of fuel for engine start, taxi and takeoff allowance.
2. Mixture may be leaned above 5000 feet for smooth engine operation and increased power.
3. Increase time, fuel and distance by 10% for each 10° C above standard temperature.
4. Distances shown are based on zero wind.

WEIGHT LBS	PRESSURE ALTITUDE FT	TEMP °C	RATE OF CLIMB FPM	FROM SEA LEVEL		
				TIME MIN	FUEL USED GALLONS	DISTANCE NM
3100	S.L.	15	540	0	0	0
	2000	11	540	4	1.0	6
	4000	7	540	7	2.1	11
	6000	3	510	11	3.2	17
	8000	-1	395	16	4.5	25
	10,000	-5	285	22	6.1	35
	12,000	-9	150	31	8.3	54

SUPPLEMENT NO. SFM7504-SW-R

SECTION 5 - PERFORMANCE (continued)

CRUISE PERFORMANCE
PRESSURE ALTITUDE 2000 FEET

CONDITIONS:
 3100 Pounds
 Recommended Lean Mixture
 Cowl Flaps Closed

NOTE

For best fuel economy at 65% power or less, operate at the leanest mixture that results in smooth engine operation or at peak EGT if an EGT indicator is installed.

		20° C BELOW STANDARD TEMP - 9° C			STANDARD TEMPERATURE 11° C			20° C ABOVE STANDARD TEMP 31° C		
RPM	MP	% BHP	KTAS	GPH	% BHP	KTAS	GPH	% BHP	KTAS	GPH
2400	22	77	132	13.1	74	133	12.6	71	134	12.2
	21	72	129	12.3	69	130	11.8	67	131	11.4
	20	67	126	11.5	65	126	11.1	63	127	10.7
	19	62	122	10.7	60	122	10.3	58	122	10.0
2300	23	78	133	13.3	75	134	12.8	72	135	12.4
	22	73	130	12.5	70	131	12.0	68	131	11.6
	21	68	126	11.7	66	127	11.3	64	128	10.9
	20	64	123	10.9	62	123	10.5	60	123	10.2
2200	23	73	130	12.5	70	131	12.0	68	131	11.6
	22	69	127	11.7	66	127	11.3	64	128	10.9
	21	64	123	11.0	62	124	10.6	60	124	10.2
	20	60	119	10.2	58	120	9.9	56	120	9.6
2100	23	68	126	11.6	66	127	11.2	64	127	10.8
	22	64	123	10.9	62	123	10.5	60	124	10.2
	21	60	119	10.2	58	120	9.9	56	120	9.6
	20	56	115	9.6	54	115	9.3	52	115	9.0
	19	52	111	9.0	50	110	8.7	48	109	8.5
	18	47	106	8.4	46	105	8.1	44	103	7.9

SUPPLEMENT NO. SFM7504-SW-R

SECTION 5 - PERFORMANCE (continued)

CRUISE PERFORMANCE
PRESSURE ALTITUDE 4000 FEET

CONDITIONS:
 3100 Pounds
 Recommended Lean Mixture
 Cowl Flaps Closed

NOTE

For best fuel economy at 65% power or less, operate at the leanest mixture that results in smooth engine operation or at peak EGT if an EGT indicator is installed.

		20° C BELOW STANDARD TEMP - 13° C			STANDARD TEMPERATURE 7° C			20° C ABOVE STANDARD TEMP 27° C		
RPM	MP	% BHP	KTAS	GPH	% BHP	KTAS	GPH	% BHP	KTAS	GPH
2400	22	-	-	-	76	137	13.0	73	138	12.5
	21	74	133	12.6	71	134	12.1	69	134	11.7
	20	69	129	11.8	66	130	11.3	64	130	11.0
	19	64	125	10.9	62	126	10.6	60	126	10.2
2300	23	-	-	-	76	138	13.1	74	139	12.6
	22	75	133	12.8	72	134	12.3	70	135	11.9
	21	70	130	12.0	68	131	11.5	65	131	11.2
	20	66	126	11.2	63	127	10.8	61	127	10.4
2200	23	75	133	12.8	72	134	12.3	70	135	11.9
	22	70	130	12.0	68	131	11.6	66	131	11.2
	21	66	127	11.3	64	127	10.9	61	127	10.5
	20	62	123	10.5	59	123	10.2	57	123	9.8
	19	57	119	9.8	55	118	9.5	53	118	9.2
2100	23	70	130	11.9	67	131	11.5	65	131	11.1
	22	66	126	11.2	63	127	10.8	61	127	10.4
	21	62	123	10.5	59	123	10.1	57	123	9.8
	20	57	119	9.8	55	119	9.5	53	118	9.3
	19	53	114	9.2	51	114	8.9	50	113	8.7
	18	49	109	8.6	47	108	8.3	46	106	8.1
	17	45	103	8.0	43	101	7.8	42	100	7.6

SUPPLEMENT NO. SFM7504-SW-R

SECTION 5 - PERFORMANCE (continued)

CRUISE PERFORMANCE
PRESSURE ALTITUDE 6000 FEET

CONDITIONS:
 3100 Pounds
 Recommended Lean Mixture
 Cowl Flaps Closed

NOTE

For best fuel economy at 65% power or less, operate at the leanest mixture that results in smooth engine operation or at peak EGT if an EGT indicator is installed.

		20° C BELOW STANDARD TEMP - 17° C			STANDARD TEMPERATURE 3° C			20° C ABOVE STANDARD TEMP 23° C		
RPM	MP	% BHP	KTAS	GPH	% BHP	KTAS	GPH	% BHP	KTAS	GPH
2400	22	-	-	-	77	141	13.3	75	142	12.8
	21	75	136	12.9	73	137	12.4	70	138	12.0
	20	71	133	12.1	68	133	11.6	66	134	11.2
	19	66	129	11.2	64	129	10.8	61	129	10.5
2300	22	77	137	13.1	74	138	12.6	71	139	12.2
	21	72	134	12.3	69	134	11.8	67	135	11.4
	20	67	130	11.5	65	130	11.1	63	131	10.7
	19	63	126	10.7	60	126	10.3	58	126	10.0
2200	22	72	134	12.3	69	135	11.9	67	135	11.5
	21	68	130	11.6	65	131	11.1	63	131	10.8
	20	63	126	10.8	61	127	10.4	59	127	10.1
	19	59	122	10.1	57	122	9.7	55	121	9.5
2100	22	67	130	11.5	66	131	11.1	63	131	10.7
	21	63	126	10.8	61	127	10.4	59	127	10.1
	19	55	118	9.5	53	117	9.2	51	116	8.9
	18	51	113	8.8	49	111	8.6	47	110	8.3
	17	47	107	8.2	45	105	8.0	43	103	7.8

SUPPLEMENT NO. SFM7504-SW-R

SECTION 5 - PERFORMANCE (continued)

CRUISE PERFORMANCE
PRESSURE ALTITUDE 8000 FEET

CONDITIONS:
 3100 Pounds
 Recommended Lean Mixture
 Cowl Flaps Closed

NOTE

For best fuel economy at 65% power or less, operate at the leanest mixture that results in smooth engine operation or at peak EGT if an EGT indicator is installed.

		20° C BELOW STANDARD TEMP - 21° C			STANDARD TEMPERATURE -1° C			20° C ABOVE STANDARD TEMP 19° C		
RPM	MP	% BHP	KTAS	GPH	% BHP	KTAS	GPH	% BHP	KTAS	GPH
2400	21	77	140	13.3	74	141	12.7	72	142	12.3
	20	72	136	12.4	70	137	11.9	67	138	11.5
	19	68	132	11.5	65	133	11.1	63	133	10.7
	18	63	128	10.7	60	128	10.3	58	128	10.0
2300	21	74	137	12.6	71	138	12.1	69	139	11.7
	20	69	134	11.8	66	134	11.3	64	134	11.0
	19	64	130	11.0	62	130	10.6	60	129	10.2
	18	60	125	10.2	58	125	9.9	56	124	9.6
2200	21	69	134	11.8	67	135	11.4	65	135	11.0
	20	65	130	11.1	63	130	10.7	60	130	10.3
	19	61	126	10.3	58	126	10.0	56	125	9.7
	18	56	121	9.7	54	120	9.3	52	119	9.1
2100	21	65	130	11.1	63	130	10.7	60	130	10.3
	20	61	126	10.4	59	126	10.0	57	125	9.7
	19	57	122	9.7	54	121	9.4	53	120	9.1
	18	52	116	9.1	50	115	8.8	49	113	8.5
	17	48	110	8.5	46	108	8.2	45	106	8.0

SUPPLEMENT NO. SFM7504-SW-R

SECTION 5 - PERFORMANCE (continued)

CRUISE PERFORMANCE
PRESSURE ALTITUDE 10,000 FEET

CONDITIONS:
 3100 Pounds
 Recommended Lean Mixture
 Cowl Flaps Closed

NOTE

For best fuel economy at 65% power or less, operate at the leanest mixture that results in smooth engine operation or at peak EGT if an EGT indicator is installed.

		20° C BELOW STANDARD TEMP - 25° C			STANDARD TEMPERATURE - 5° C			20° C ABOVE STANDARD TEMP 15° C		
RPM	MP	% BHP	KTAS	GPH	% BHP	KTAS	GPH	% BHP	KTAS	GPH
2400	20	74	140	12.7	71	141	12.2	69	141	11.8
	19	69	136	11.8	67	137	11.4	64	137	11.0
	18	65	132	11.0	62	132	10.6	60	131	10.2
	17	60	127	10.2	57	126	9.8	55	125	9.5
2300	20	71	137	12.1	68	138	11.6	66	138	11.2
	19	66	133	11.3	64	133	10.9	61	133	10.5
	18	61	129	10.5	59	128	10.1	57	128	9.8
	17	57	123	9.7	55	122	9.4	53	121	9.1
2200	20	67	134	11.4	64	134	11.0	62	134	10.6
	19	62	129	10.6	60	129	10.2	58	129	9.9
	18	58	125	9.9	56	124	9.6	54	123	9.3
	17	53	119	9.2	51	118	8.9	50	116	8.7
2100	20	63	130	10.7	60	130	10.3	58	129	9.9
	19	58	125	10.0	56	124	9.6	54	123	9.4
	18	54	120	9.3	52	119	9.0	50	117	8.8
	17	50	114	8.7	48	112	8.4	46	110	8.2
	16	46	107	8.1	44	104	7.8	42	102	7.6

SUPPLEMENT NO. SFM7504-SW-R

SECTION 5 - PERFORMANCE (continued)

CRUISE PERFORMANCE
PRESSURE ALTITUDE 12,000 FEET

CONDITIONS:
 3100 Pounds
 Recommended Lean Mixture
 Cowl Flaps Closed

NOTE

For best fuel economy at 65% power or less, operate at the leanest mixture that results in smooth engine operation or at peak EGT if an EGT indicator is installed.

		20° C BELOW STANDARD TEMP - 29° C			STANDARD TEMPERATURE -9° C			20° C ABOVE STANDARD TEMP 11° C		
RPM	MP	% BHP	KTAS	GPH	% BHP	KTAS	GPH	% BHP	KTAS	GPH
2400	18	66	136	11.3	64	136	10.9	61	135	10.5
	17	61	130	10.5	59	130	10.1	57	129	9.8
	16	56	124	9.7	54	123	9.4	52	122	9.1
	15	51	117	9.0	50	116	8.7	48	114	8.4
2300	18	63	132	10.8	61	132	10.4	59	131	10.0
	17	58	127	10.0	56	126	9.7	54	125	9.4
	16	54	121	9.3	52	119	9.0	50	117	8.7
	15	49	113	8.6	47	112	8.3	45	109	8.1
2200	18	59	128	10.2	57	128	9.8	55	126	9.5
	17	55	123	9.5	53	121	9.2	51	119	8.9
	16	51	116	8.8	49	114	8.5	47	112	8.3
	15	46	108	8.2	44	106	7.9	43	103	7.7
2100	18	56	124	9.6	54	122	9.3	52	120	9.0
	17	51	117	8.9	49	115	8.7	48	113	8.4
	16	47	110	8.3	45	108	8.1	44	106	7.8

SUPPLEMENT NO. SFM7504-SW-R

SECTION 5 - PERFORMANCE (continued)

**RANGE PROFILE
45 MINUTES RESERVE
56 GALLONS USABLE FUEL**

CONDITIONS:
3100 Pounds
Recommended Lean Mixture for Cruise
Standard Temperature
Zero Wind

- NOTES:
1. This chart allows for the fuel used for engine start, taxi, takeoff and climb, and the distance during a normal climb as shown in the table "TIME, FUEL, AND DISTANCE TO CLIMB - NORMAL CLIMB - 90 KIAS" found in this supplement.
 2. Reserve fuel is based on 45 minutes at 45% BHP and is 6 gallons.

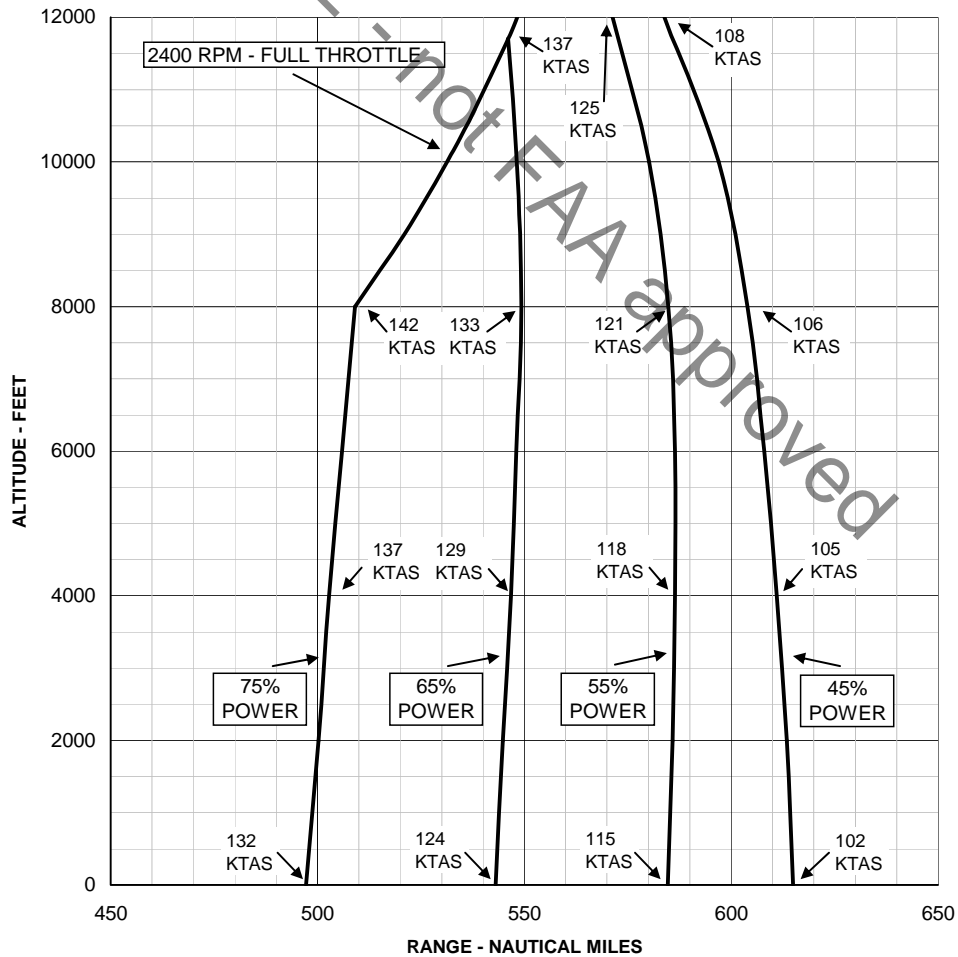

SUPPLEMENT NO. SFM7504-SW-R

SECTION 5 - PERFORMANCE (continued)

**RANGE PROFILE
45 MINUTES RESERVE
75 GALLONS USABLE FUEL**

CONDITIONS:
3100 Pounds
Recommended Lean Mixture for Cruise
Standard Temperature
Zero Wind

NOTES:

1. This chart allows for the fuel used for engine start, taxi, takeoff and climb, and the distance during a normal climb as shown in the table "TIME, FUEL, AND DISTANCE TO CLIMB - NORMAL CLIMB -90 KIAS" found in this supplement.
2. Reserve fuel is based on 45 minutes at 45% BHP and is 6 gallons.

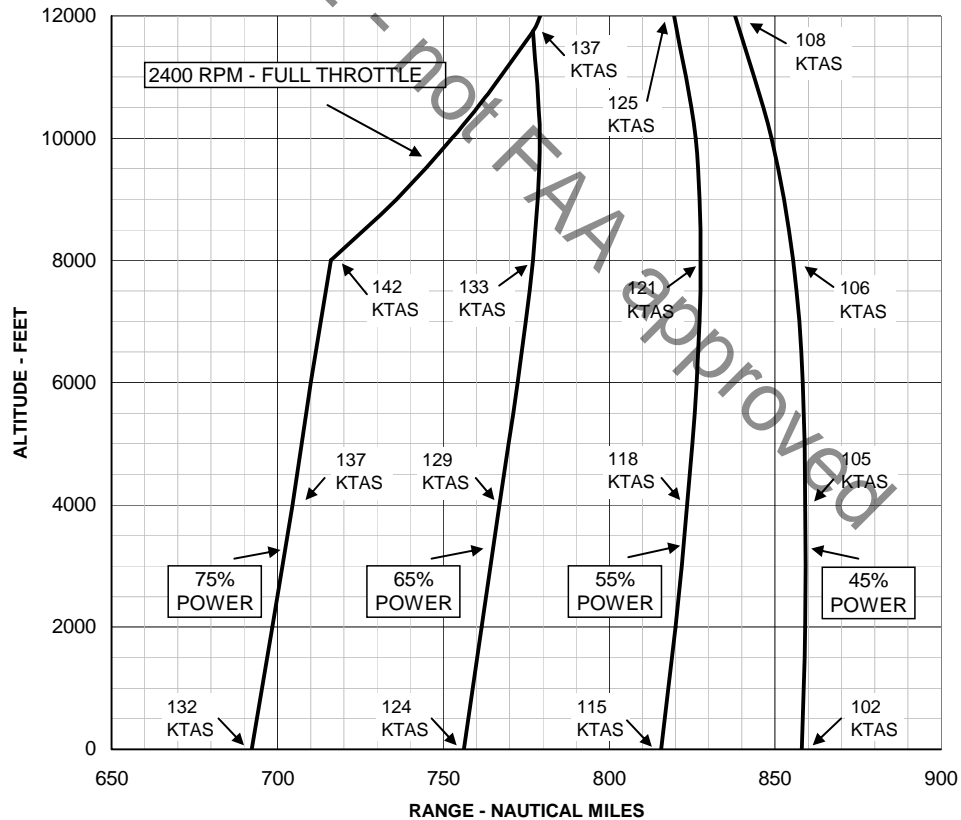

SUPPLEMENT NO. SFM7504-SW-R

SECTION 5 - PERFORMANCE (continued)

**ENDURANCE PROFILE
45 MINUTES RESERVE
56 GALLONS USABLE FUEL**

CONDITIONS:
3100 Pounds
Recommended Lean Mixture for Cruise
Standard Temperature
Zero Wind

NOTES:

1. This chart allows for the fuel used for engine start, taxi, takeoff and climb, and the time during a normal climb as shown in the table "TIME, FUEL, AND DISTANCE TO CLIMB - NORMAL CLIMB - 90 KIAS" found in this supplement.
2. Reserve fuel is based on 45 minutes at 45% BHP and is 6 gallons.

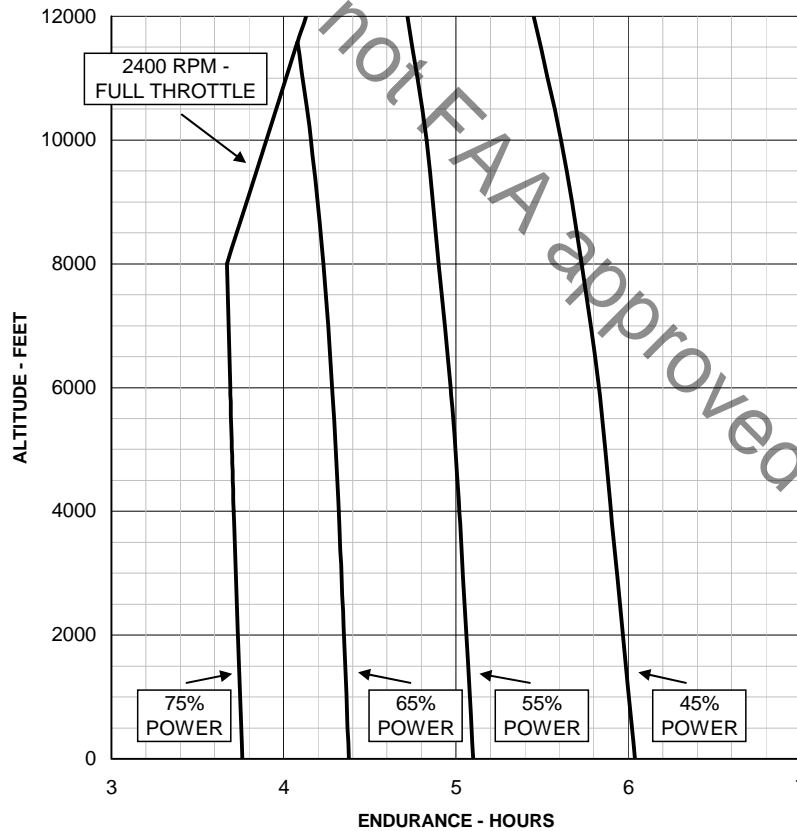

SUPPLEMENT NO. SFM7504-SW-R

SECTION 5 - PERFORMANCE (continued)

**ENDURANCE PROFILE
45 MINUTES RESERVE
75 GALLONS USABLE FUEL**

CONDITIONS:
3100 Pounds
Recommended Lean Mixture for Cruise
Standard Temperature
Zero Wind

NOTES:

1. This chart allows for the fuel used for engine start, taxi, takeoff and climb, and the time during a normal climb as shown in the table "TIME, FUEL, AND DISTANCE TO CLIMB - NORMAL CLIMB - 90 KIAS" found in this supplement.
2. Reserve fuel is based on 45 minutes at 45% BHP and is 6 gallons.

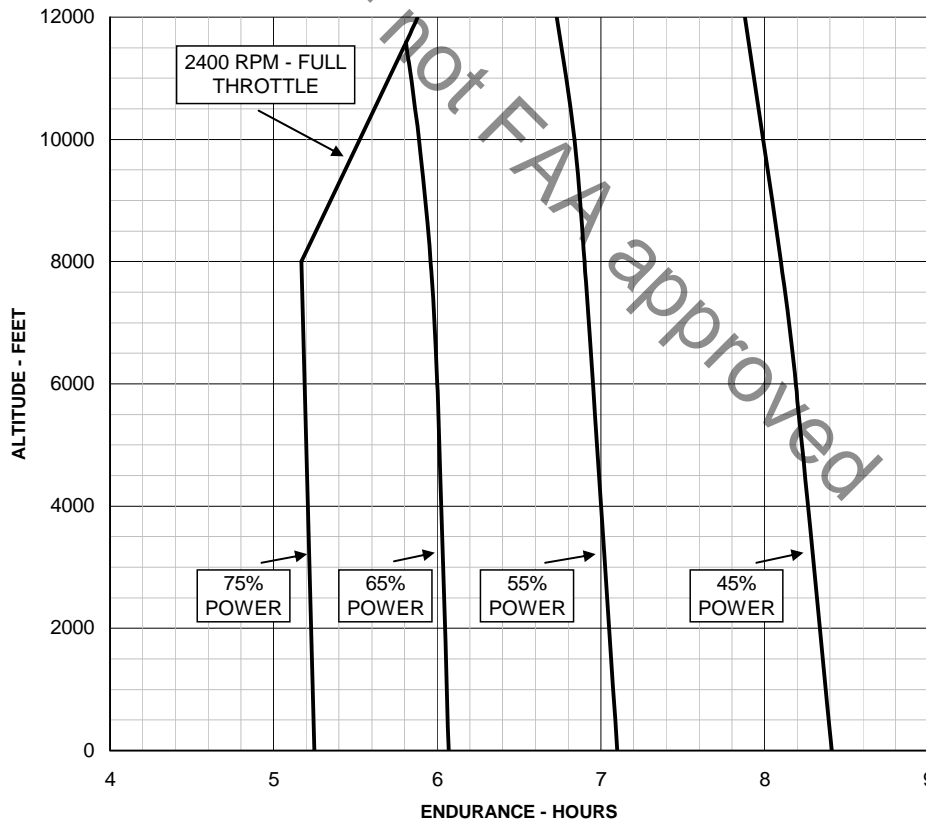

SUPPLEMENT NO. SFM7504-SW-R

SECTION 6 - WEIGHT & BALANCE / EQUIPMENT LIST

Center of gravity limitations and envelopes are changed for operation at weights above 2950 lbs. to and including 3100 lbs. Use the following limit and moment envelopes:

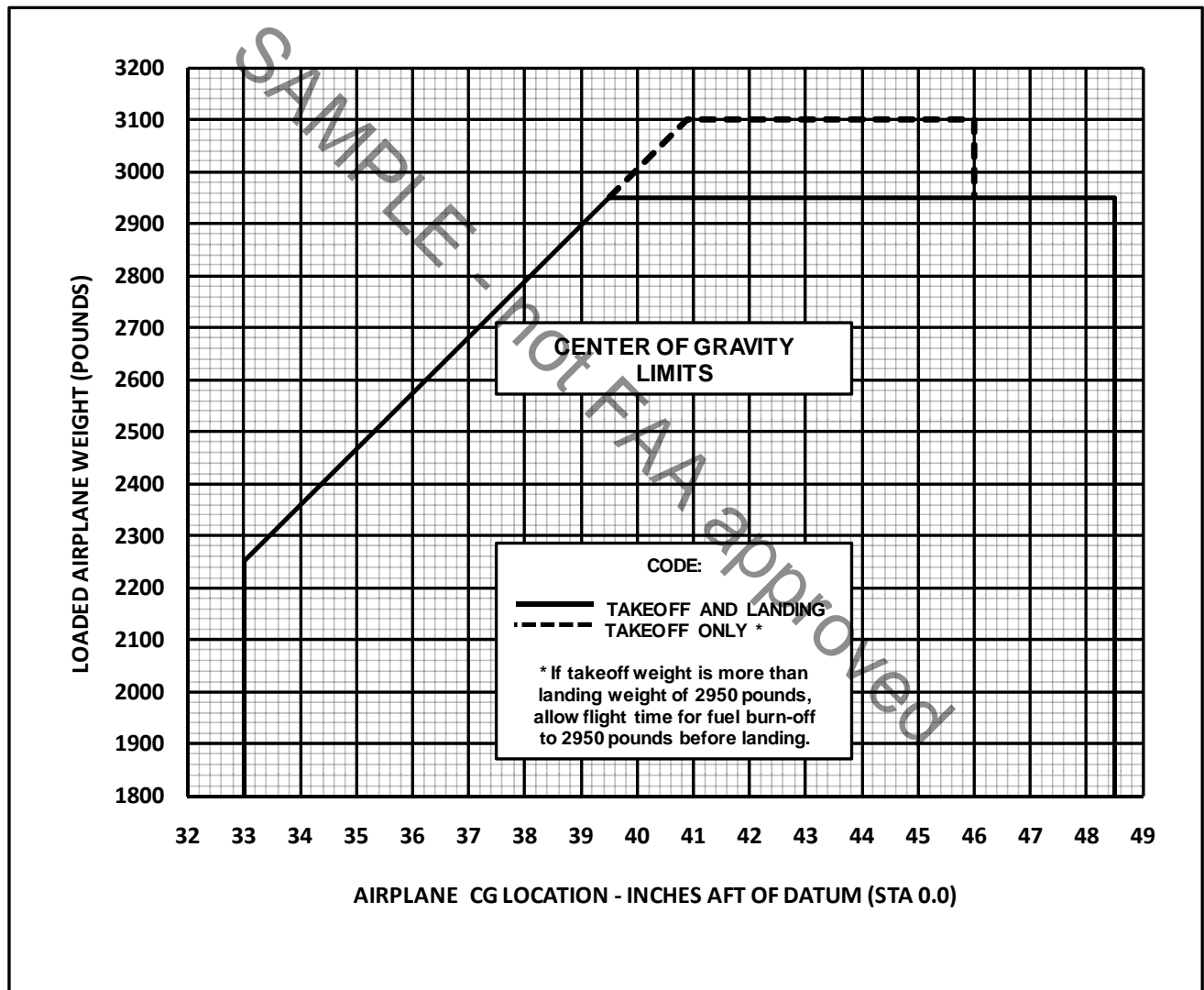

SUPPLEMENT NO. SFM7504-SW-R

SECTION 6 - WEIGHT & BALANCE / EQUIPMENT LIST (continued)

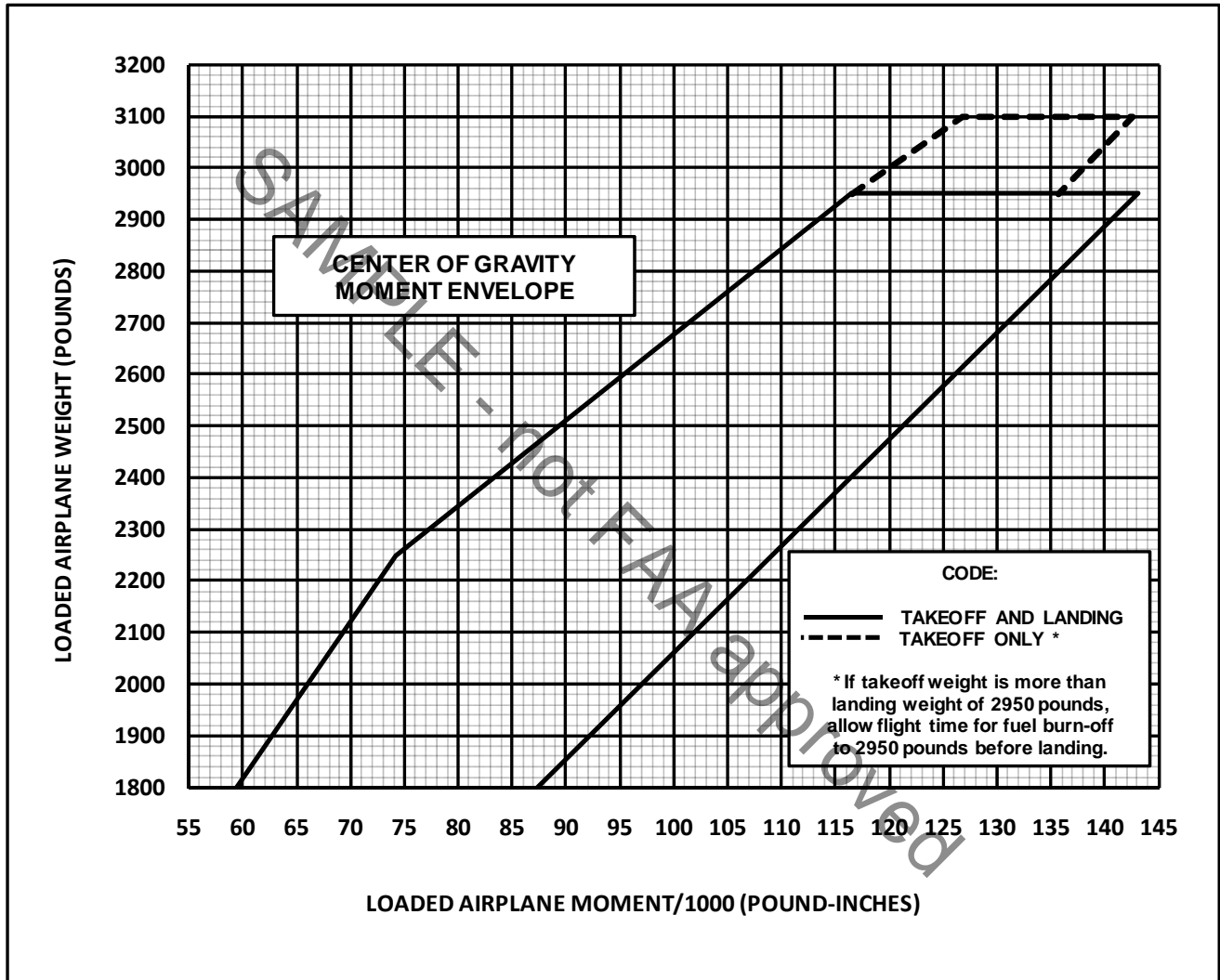

TROLLTUNE CORPORATION
2710 Thomes Avenue
Cheyenne, WY 82001

SUPPLEMENT AIRPLANE FLIGHT MANUAL FOR
CESSNA 182Q
MAXIMUM GROSS WEIGHT INCREASE
STC No. SA03608AT

SUPPLEMENT NO. SFM7504-SW-R

SECTION 7 - AIRPLANE SYSTEMS AND DESCRIPTIONS

NO CHANGES

SECTION 8 - HANDLING, SERVICE & MAINTENANCE

NO CHANGES

SECTION 9 - SUPPLEMENTS

ADDED THIS SUPPLEMENTAL AIRPLANE FLIGHT MANUAL, SFM7504-SW-R

SAMPLE - not FAA approved