



Designed to last beautifully.™

TRIM

MOULDING

DECK

PORCH

RAIL

PAVERS



AZEK Rail Install Guide

Installing AZEK Rail with Glass Infill	2
Installing AZEK Rail Stairs with Glass Infill	9
Notes.....	14

- Please read all instructions completely before starting any part of the installation.
- AZEK Rail should be installed using the same good building principles used to install wood or composite railing and in accordance with the local building codes and the installation guidelines included below. AZEK Building Products Inc. accepts no liability or responsibility for the improper installation of this product.
- AZEK Rail may not be suitable for every application and it is the sole responsibility of the installer to be sure that AZEK Rail is fit for the intended use. Since all installations are unique, it is also the installer’s responsibility to determine specific requirements in regards to each Rail application.
- AZEK Building Products Inc. recommends that all applications be reviewed by a licensed architect, engineer or local building official before installation. If you have any questions or need further assistance, please call AZEK Customer Service at 877-ASK-AZEK (877-275-2935) or visit our website at www.azek.com.
- AZEK Railing is tested as a whole system and should be used that way. It is not intended to be used in conjunction with other railing systems or fasteners.
- The following Installation Guidelines are applicable for installation of AZEK Premier, AZEK Trademark, and AZEK Reserve Rail Systems (except AZEK Reserve over post applications).
- **IMPORTANT:** Make sure the DRIVE TOOL/DRILL is configured or set to use the SCREW setting when driving and/or tightening all FASTENERS.
- **SAFETY:** Always wear goggles when handling, cutting, drilling and fastening materials.
- Failure to install this product in accordance with applicable building codes and AZEK’s written Rail Install Guide may lead to personal injury, affect rail system performance and void the product warranty.

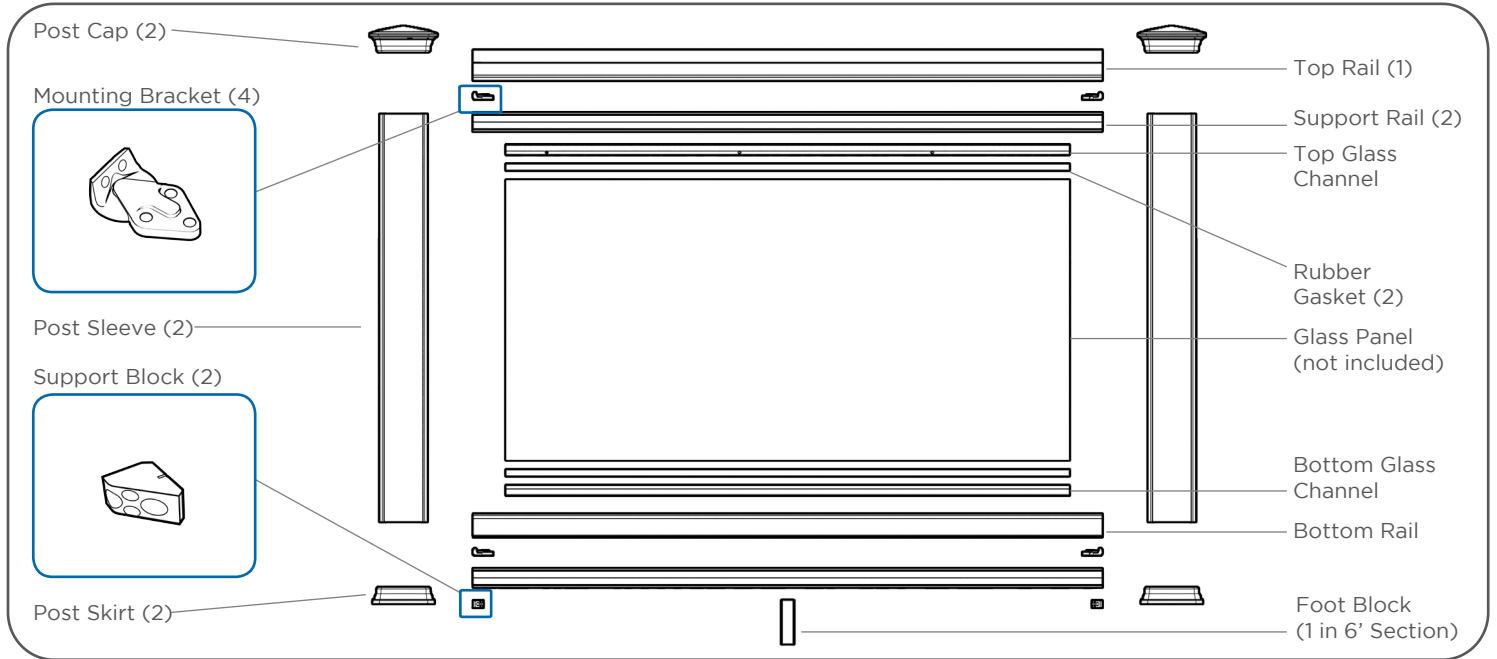

AZEK Rail with Glass Infill is available in 6' lengths.

Visit www.azek.com/installation to view AZEK installation videos. Consult your local building codes for guard and handrail requirements.

- Tools Required**
- Miter Saw
 - Drill
 - Measuring Tape
 - 7/64" Drill Bit
 - 3/16" Drill Bit

Measuring Your Railing Area

- Measurements are from center to center of post. Rails are produced in 6' lengths to allow for finished end cuts and angles.
- Determine how many 6' AZEK Custom Rail Packs you need and check to be sure you have all the components (and quantities) listed in the chart shown to the right.

Important Information

- ⚠ AZEK Rail 6' Rails are designed not to exceed 6' center of post to center of post.
- Cut slowly, using a fine tooth saw blade to avoid chipping.
- For 42" railing use 54" Post Sleeves.

Component Dimensions

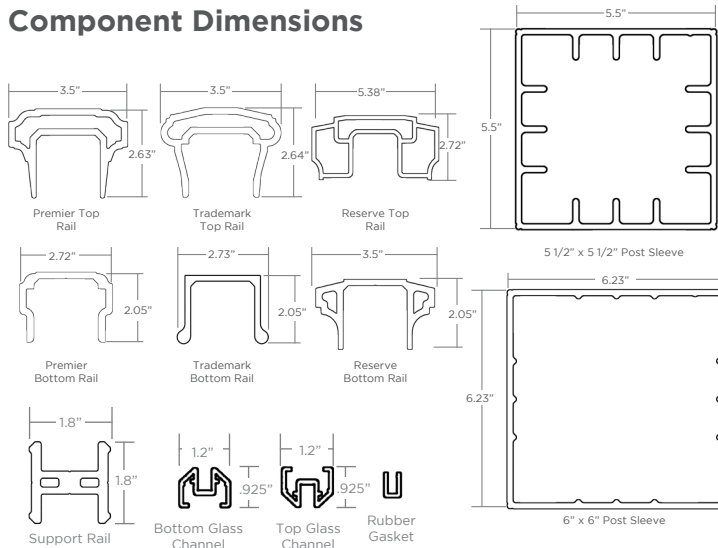

Components Needed For Installing The AZEK Rail Section

<p>Components available separately for mix-and-match rail systems</p>	<p>AZEK Custom Rail Pack</p> <ul style="list-style-type: none"> 1 - Top Rail 1 - Bottom Rail 2 - Support Rails Hardware Mounting Kit Support Block Mounting Templates 1 - Foot Block
<p>Hardware included in Hardware Kits:</p>	<ul style="list-style-type: none"> 4 - Mounting Brackets 2 - Support Blocks 16 - #8 x 3/4" Screws 6 - #8 x 1 3/4" Screws 6 - #8 x 2 5/8" Screws (Stairs Only) 6 - #8 x 3" Screws 12 - #8 x 3" Green Screws T20 Driver Bit
<p>Glass Hardware Pack</p>	<ul style="list-style-type: none"> 1 - Top Glass Channel 1 - Bottom Glass Channel 2 - Rubber Gaskets 6 - #8 x 2 1/4" Screws 6 - #8 x 3" Screws 3 - #8 x 1" Screws
<p>Additional Components Needed for Each System</p>	<p>⚠ 1/4" Tempered Glass must be sourced locally (See attached reference sheet).</p> <ul style="list-style-type: none"> 2 - Post Caps 2 - Post Sleeves 2 - Post Skirts

DIMENSIONAL CONSTRAINTS FOR STRAIGHT SECTION

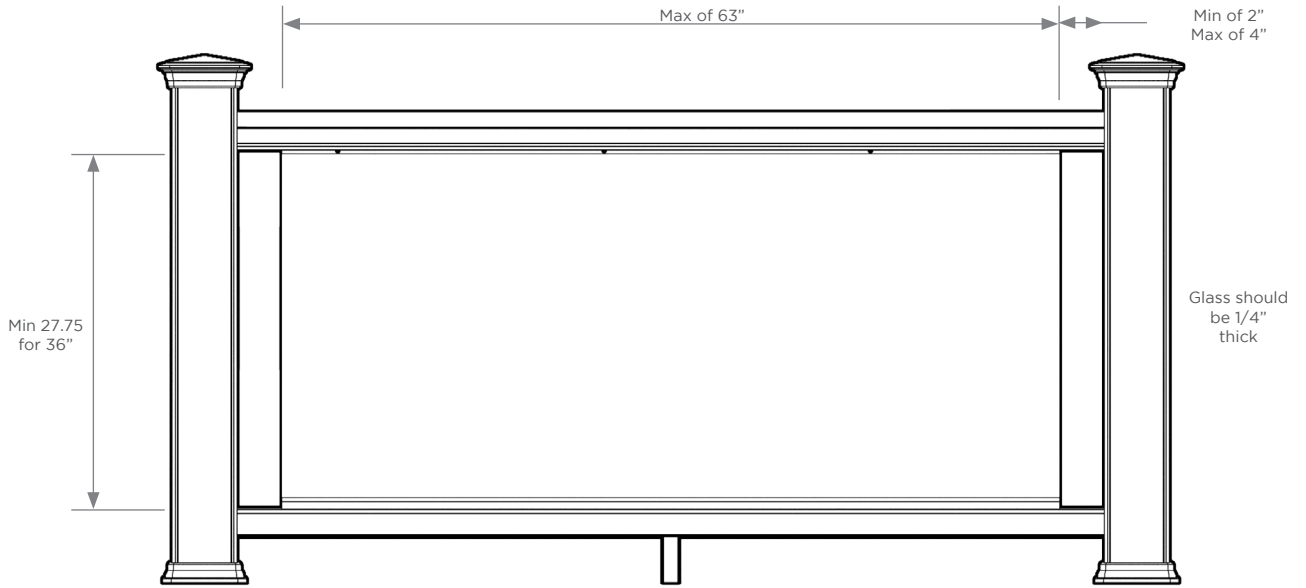

DIMENSIONAL CONSTRAINTS FOR STAIR SECTION

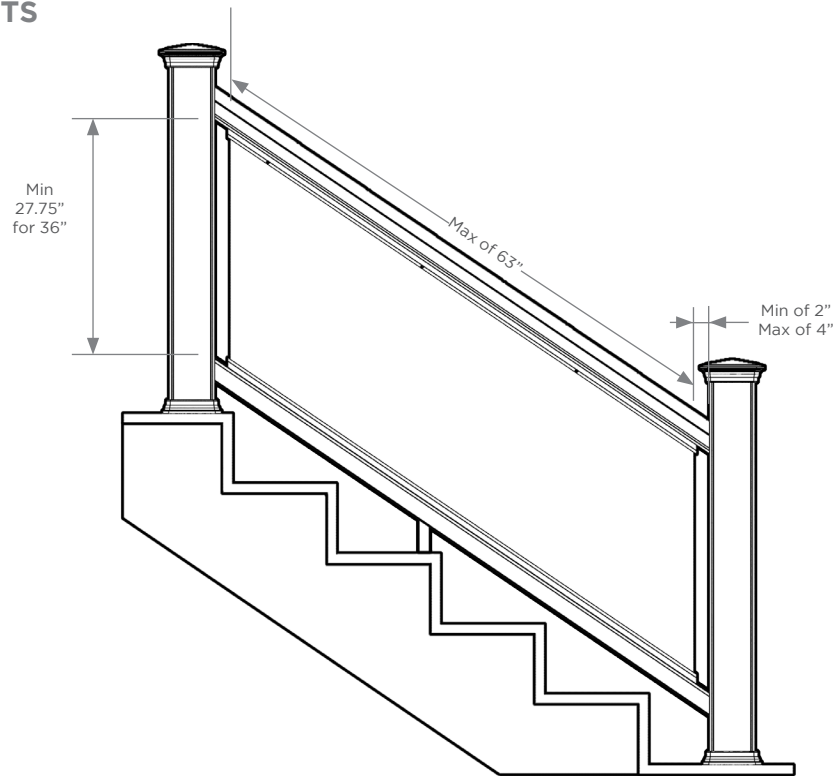

1

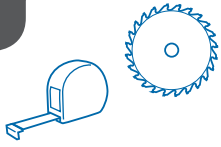

INSTALL POST SLEEVES

- Trim Post Sleeves to desired length.
- Slide Post Sleeve and Post Skirt over post. (DO NOT FORCE)
- Ensure post are square and plumb.

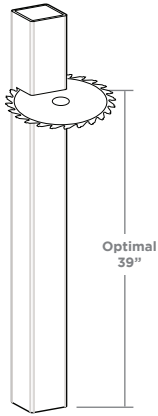

39" above deck surface is optimal for 36" railing heights.

2

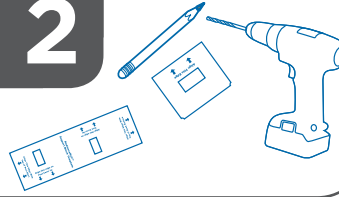

INSTALL LOWER SUPPORT BLOCK

- Position template at bottom of post sleeve above post skirt.

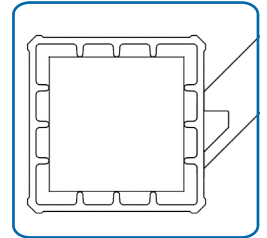
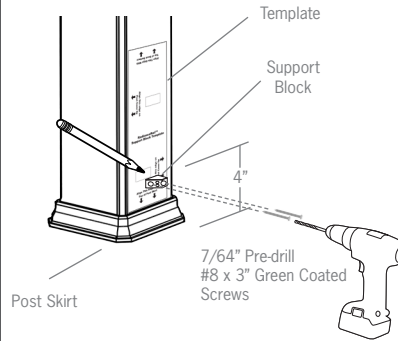

For angled rail installations - align angled face of Support Block parallel to rail section.

If you do not have a the template, position the top of the Support Block 4" above the deck.

3

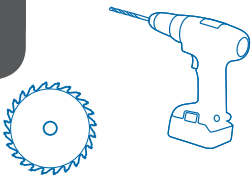

CUT AND ASSEMBLE BOTTOM SUPPORT RAIL

- Cut the Bottom Support Rail to length.

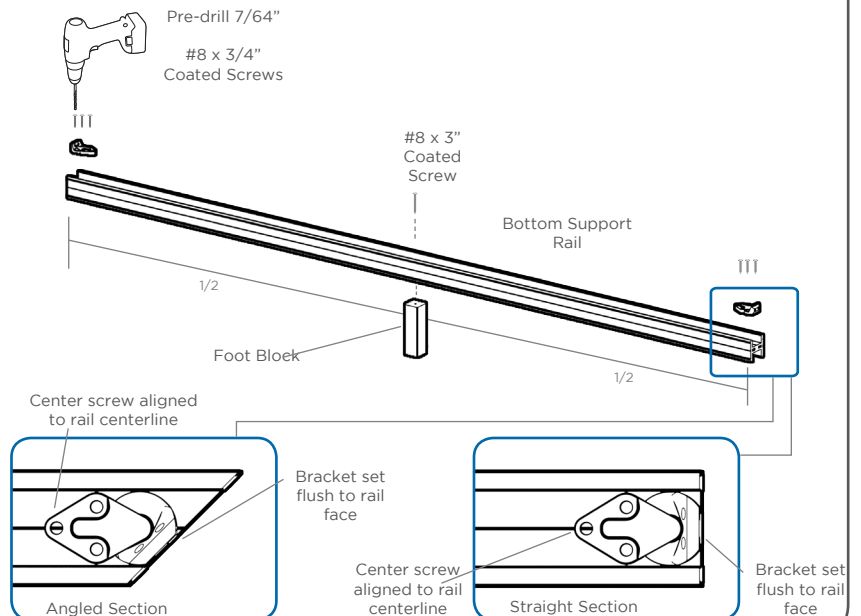

For sections up to 6': Place one Foot Block in the center of the rail

4

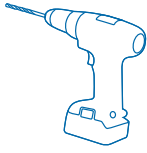

INSTALL BOTTOM SUPPORT RAIL

- Position rail assembly onto Support Blocks.

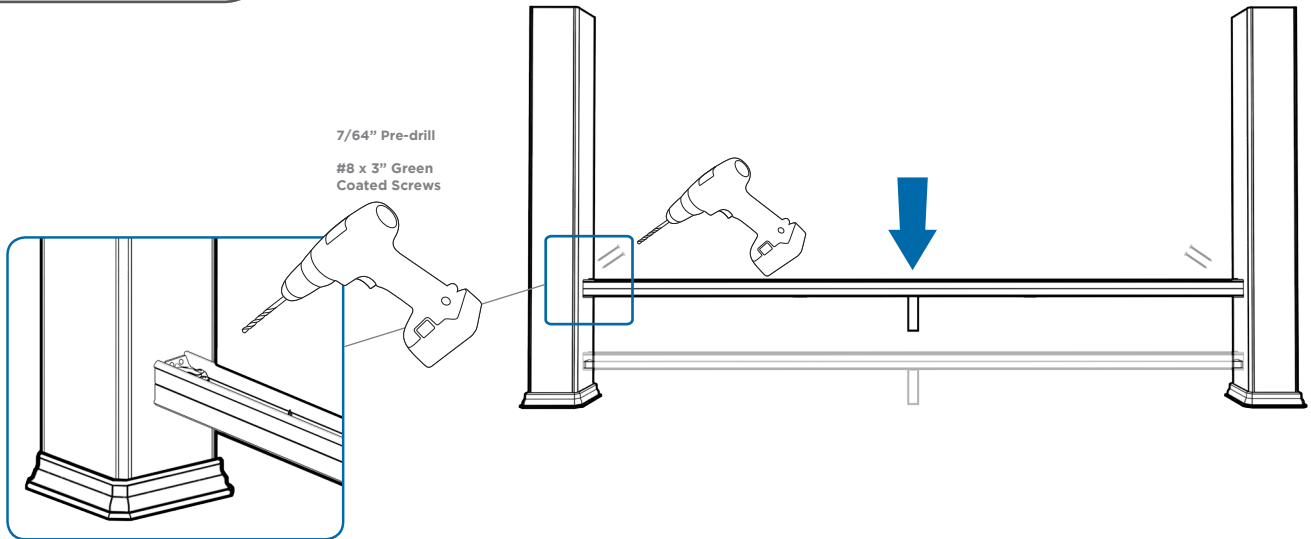

5

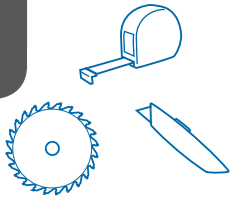

TRIM RAILS, EXTRUSIONS, AND GASKETS

- Measure distance between the posts at the Bottom Support Rail.
- Transfer measurement to Top & Bottom Rails, Top Support Rail and cut to length.
- Measure and cut Top and Bottom Glass Channels, and Rubber Gaskets to appropriate lengths.

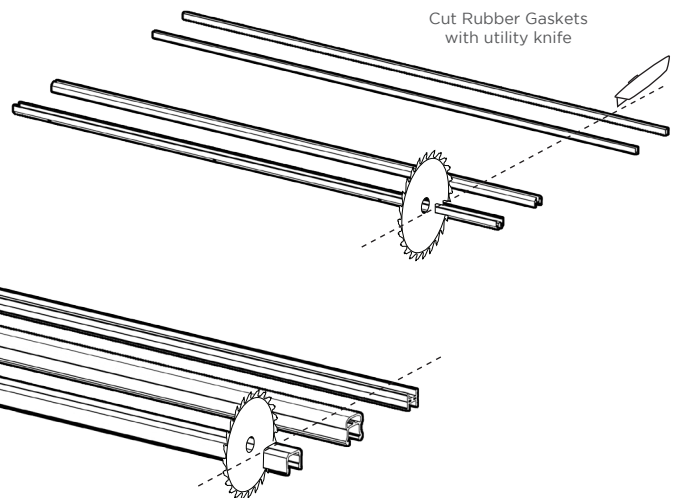

Glass Channels must be at least 4" shorter than rail.

6



ASSEMBLE LOWER RAIL SECTION

- Place Bottom Rail over Bottom Support Rail.
- Install Bottom Glass Channel utilizing pre-drilled holes.

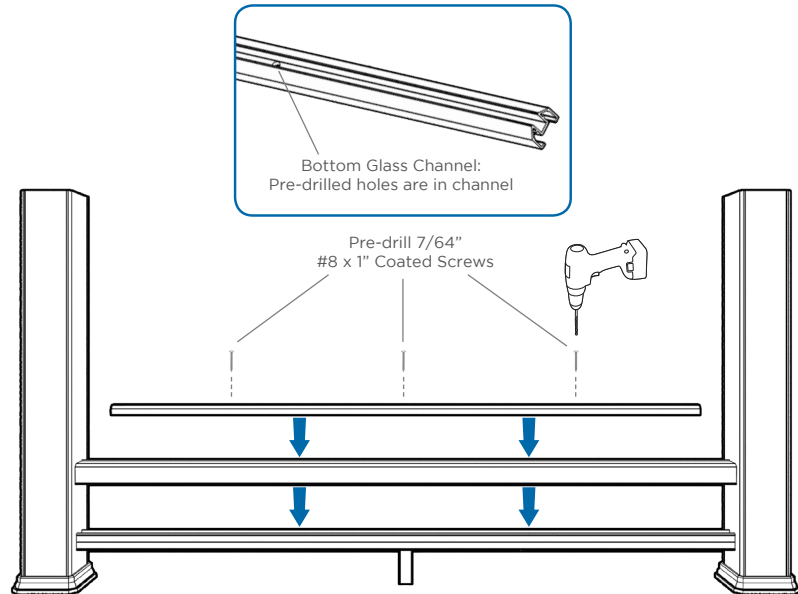

7

ATTACH LOWER GASKET AND INSTALL GLASS PANEL

- Apply Rubber Gasket to bottom of Glass Panel first.
- Set panel/gasket assembly into Bottom Glass Channel.

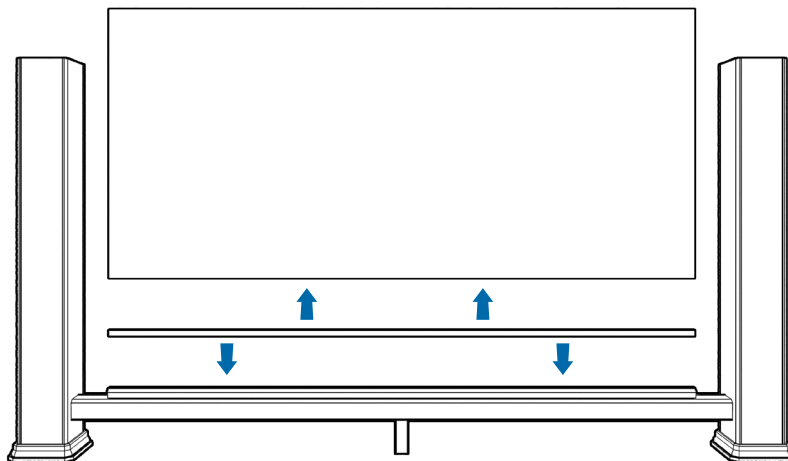

8

INSTALL TOP GASKET AND TOP GLASS CHANNEL

- Place Rubber Gasket on top of glass panel.
- Fit Top Glass Channel onto glass panel assembly.

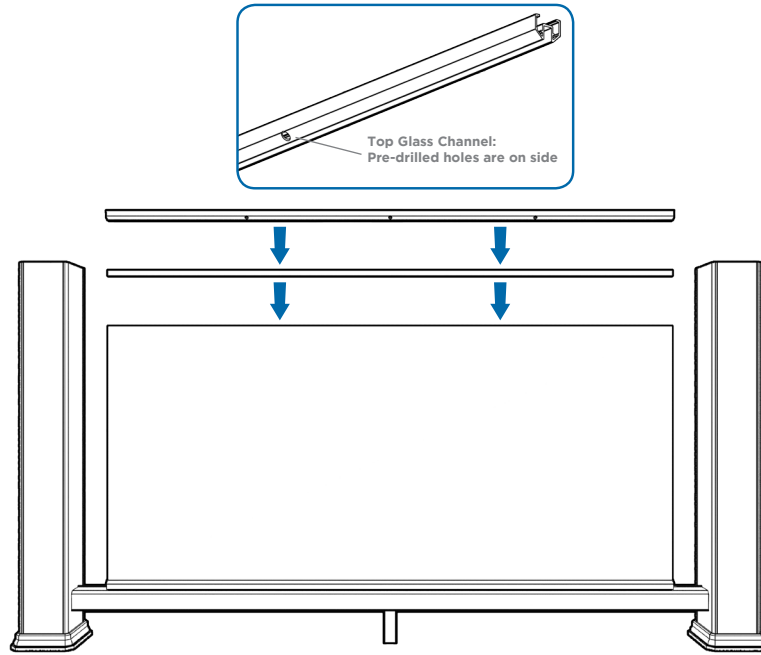

9



INSTALL TOP SUPPORT RAIL

- Align top Support Rail to center of Posts.
- Attach Brackets to Top Support Rail.

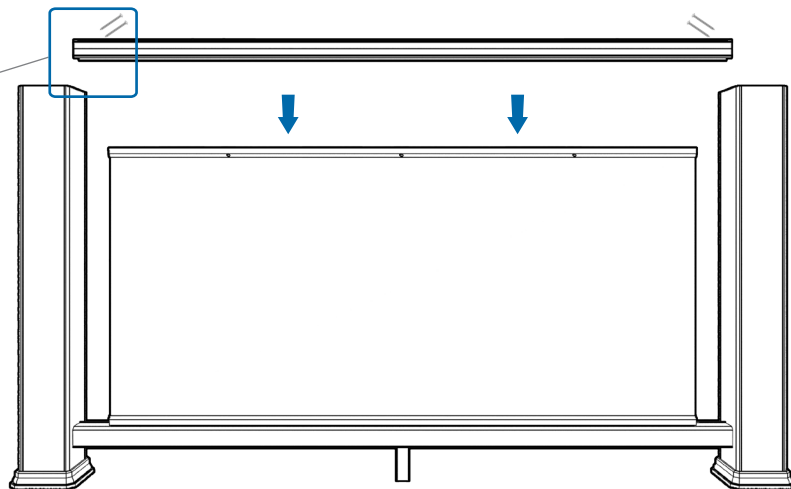
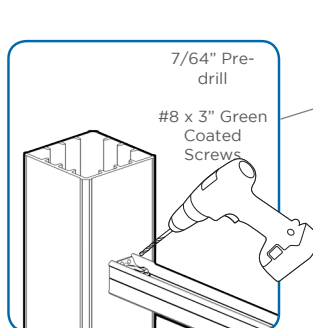
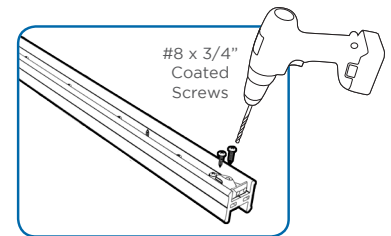

10



INSTALL TOP RAIL AND POST CAPS

- Attach Post Caps using exterior grade caulk applied to the underside of the Cap.

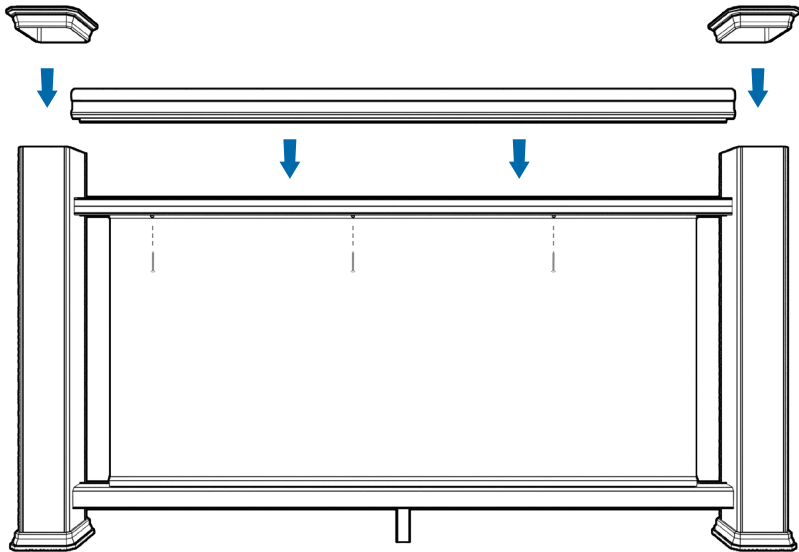
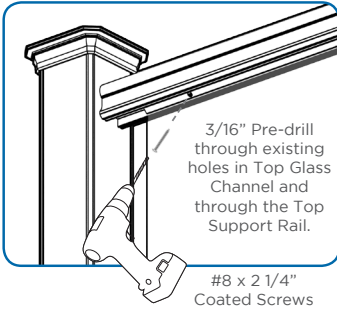

Caution: Screws must be 2 1/4" to attach the Top Rail on the Straight Rail sections.



Consult your local building codes for guard and handrail requirements.

1

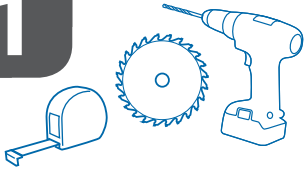

INSTALL POST COVERS

- Trim Post Sleeve to desired length.
- Slide Post Sleeve and Post Skirt over post. (do not force).
- Ensure Posts are square and plumb.

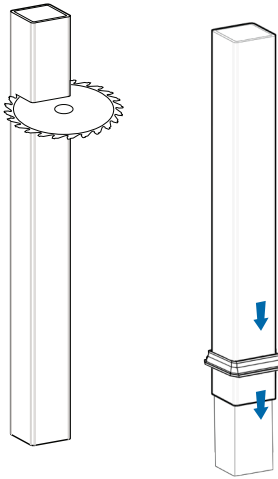

2

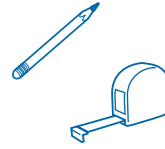

MEASURE RAILS

- Determine measurements and angle as shown. Transfer measurements to Top and Bottom Support Rails.

Support Rails are rotated 90° for stair rail applications.

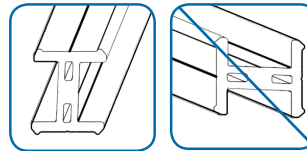

Right

Wrong

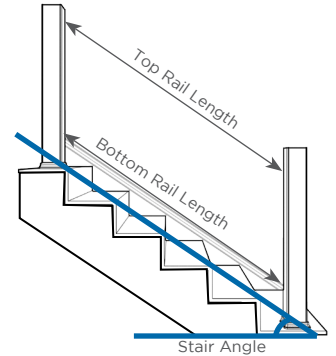

3

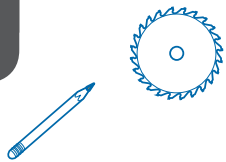

TRIM RAILS

- First trim both Top and Bottom Support Rails to dimensions from Step 2. TEST FIT for accuracy.
- Transfer measurement from Bottom and Top Support Rails to Bottom and Top Rails.
- Trim all Rails to measured lengths at appropriate angle.

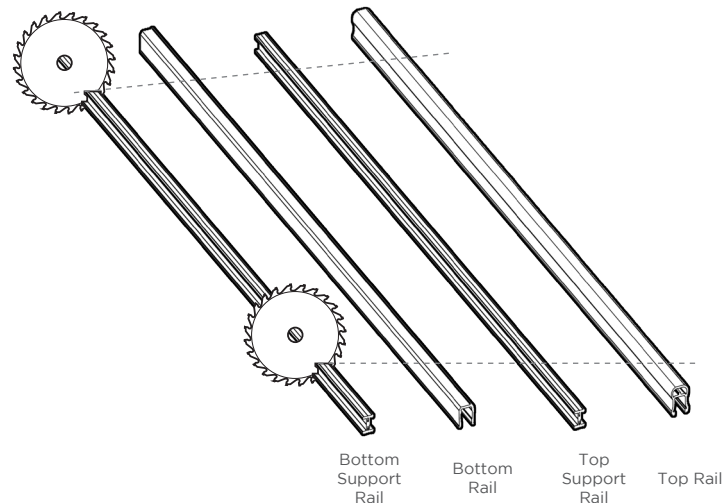

Bottom Support Rail

Bottom Rail

Top Support Rail

Top Rail

4

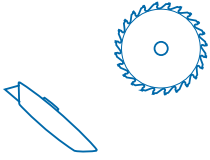

TRIM GLASS CHANNELS AND GASKETS

- Using lengths in Step 3 as a reference, measure and cut Top and Bottom Glass Channels, as well as both Rubber Gaskets at appropriate angle.



Glass Channels must be at least 4" shorter than rail.

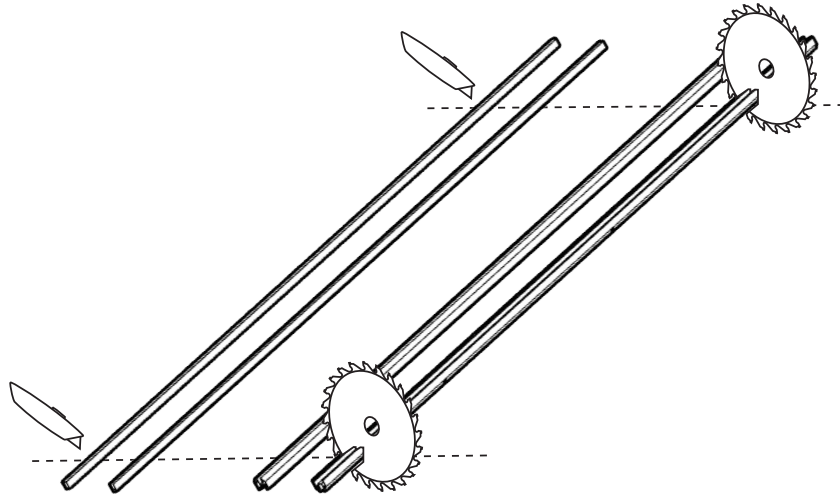

5



INSTALL BOTTOM SUPPORT RAIL

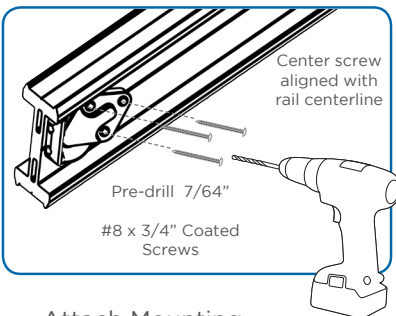

- Attach Mounting Brackets to Top AND Bottom Support Rails.

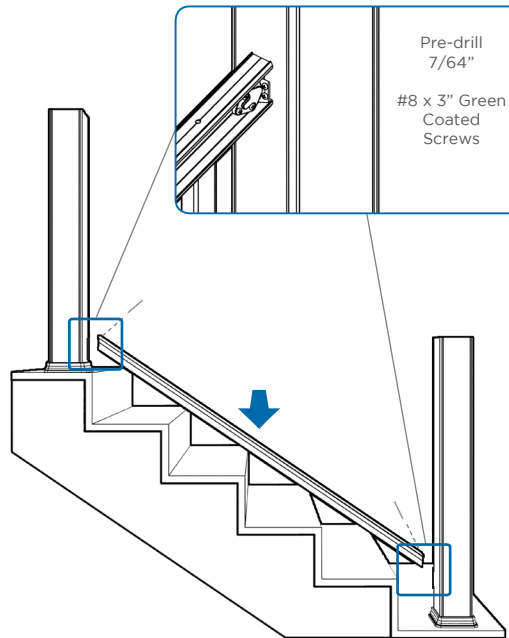

- Position Bottom Support Rail on the center of the posts and secure Mounting Brackets to posts.

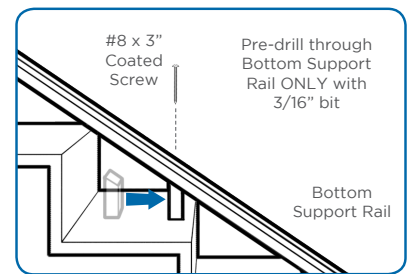

- Trim Foot Block and wedge under Support Rail & Attach.

6**ASSEMBLE LOWER RAIL SECTION**

- Place Bottom Rail over Bottom Support Rail.
- Install Bottom Glass Channel utilizing pre-drilled holes.

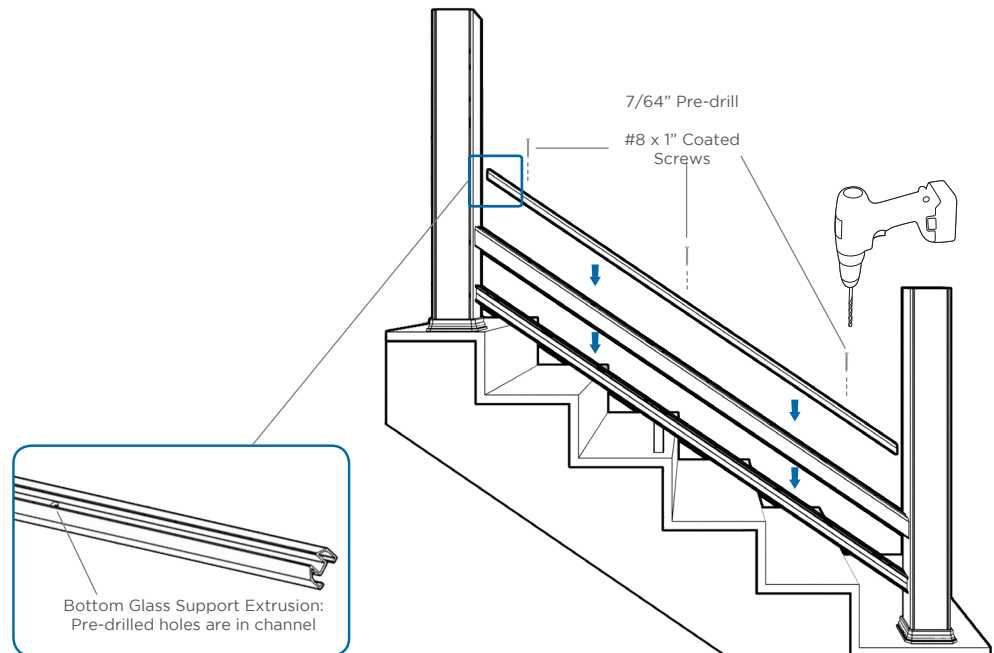
**7****ATTACH LOWER GASKET AND INSTALL GLASS PANEL**

- Apply Rubber Gasket to bottom of Glass Panel first.
- Set panel/gasket assembly into Bottom Glass Channel.

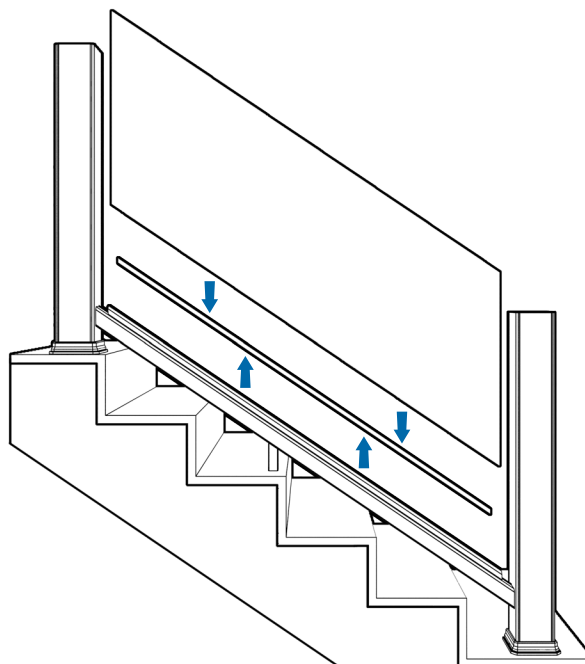

8

INSTALL TOP GASKET AND TOP GLASS CHANNEL

- Place Rubber Gasket on top of glass panel.
- Fit Top Glass Channel onto glass panel assembly.

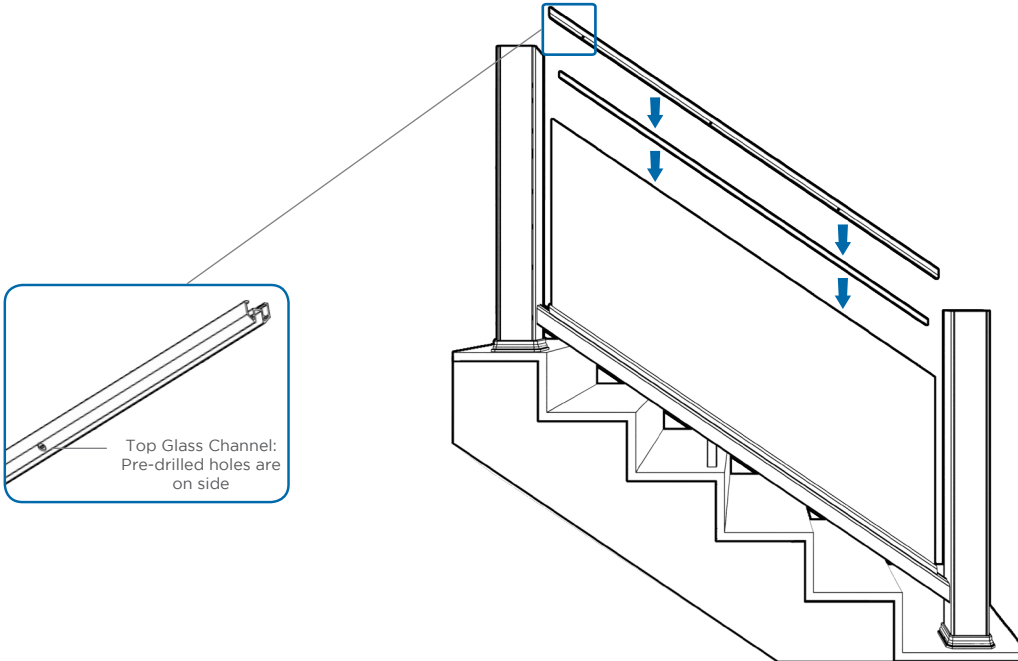

9

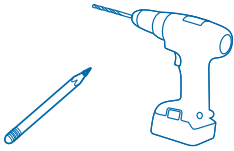

INSTALL TOP SUPPORT RAIL

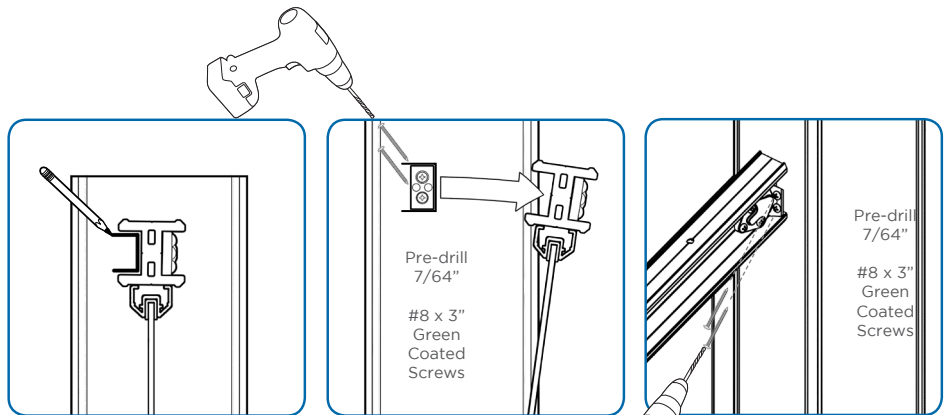
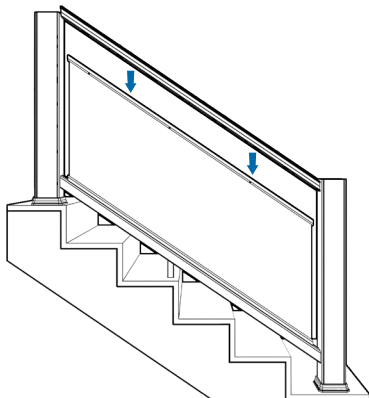

- Mark Ends of Top Support Rail.

- Rotate Rail assembly out of way to fasten Support Block

- Secure Mounting Brackets to Posts.

11



INSTALL TOP RAIL AND POST CAPS

- Attach Post caps using exterior grade caulk applied to the underside of the cap.

3/16" Pre-drill through existing holes in Top Glass Channel.

#8 x 3" Coated Screws

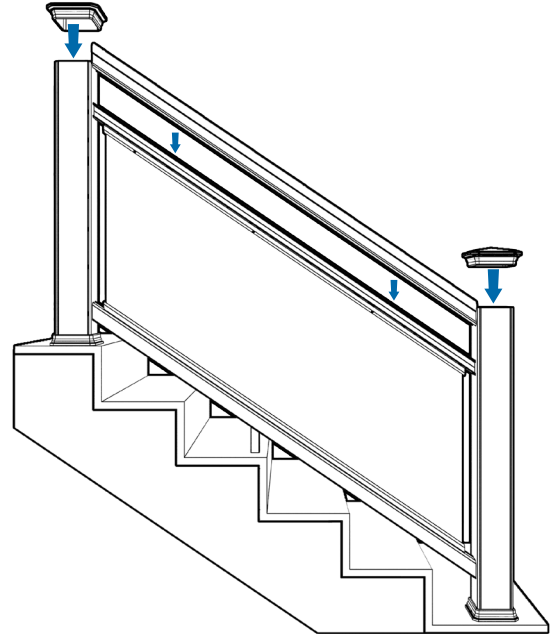
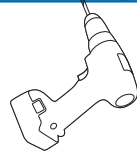
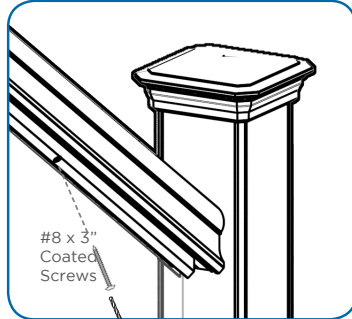

Screws must be 3" to attach the Top Rail on stair sections.



AZEK Building Products, Inc.
888 North Keyser Avenue • Scranton, PA 18504
www.AZEK.com • (877) ASK-AZEK (877) 275-2935