



SmarterGlass

state-of-the-art display solutions

www.smarterglass.com
978 997 4104
sales@smarterglass.com



Chunghwa Picture Tubes, Ltd.

Technical Specification

CPT TFT-LCD
CLAA 220WA01

APPROVED BY	CHECKED BY	PREPARED BY

Prepared by : Design General Division

Doc. No:	CLAA220WA01	Issue Date:	2007/03/19
----------	--------------------	-------------	------------

Title : CLAA220WA01 Technical Specification

1. OVERVIEW

CLAA220WA01 is 21.6” color TFT-LCD (Thin Film Transistor Liquid Crystal Display) module composed of LCD panel, driver ICs, control circuit and backlight. By applying 6 bit digital data, 1680×1050, 16.7M-color images are displayed on the 21.6” diagonal screen. Input power voltage is 5.0V for LCD driving. Inverter for backlight is not included in this module. General specification is summarized in the following table:

ITEM	SPECIFICATION
Display Area(mm)	464.94 (H) × 290.5875 (V) (22.0-inch diagonal)
Number of Pixels	1680 (H) × 1050(V)
Pixel Pitch(mm)	0.27675(H) × 0.27675(V)
Color Pixel Arrangement	RGB vertical stripe
Display Mode	Normally white, TN
Number of Colors	16.7M(6bits+Hi-FRC)
Brightness(cd/m ²)	300cd/m ² (Typ.)(center, 7.0mA)
Viewing Angle(H/V)	170/160 (Typ.)
Surface Treatment	Anti-glare, 3H
Power consumption(W)	34.0(Typ.) (w/o Inverter)
Module Size(mm)	493.7 (W) × 320.1 (H) ×16.5 (D) (Typ.)
Module Weight(g)	3000(Typ.)
Backlight Unit	CCFL, 4 tubes(top × 2/bottom × 2) , Edge light

Title : CLAA220WA01 Technical Specification

2. ABSOLUTE MAXIMUM RATINGS

ITEM	SYMBOL	MIN.	MAX.	UNIT	REMARK	
Power Supply Voltage for LCD	VCC	0	6	V		
Lamp Voltage	Delta	VL	830	965	Vrms	
	STI	VL	850	1050	Vrms	
Lamp Current	Delta	ILO	3	8	mArms	
	STI	ILO	3	8	mArms	
Lamp Frequency	FL	40	80	kHz		
static electricity	VESDt	-200	200	V	*5)	
	VESDc	-8000	8000	V		
Operation Temperature	Top	0	50	°C	*1). 2). 3). 6)	
Storage Temperature	Tstg	-20	60	°C	*1). 2). 3)	
Delayed Discharge Time	TD	--	1	sec	*8)	

[Note]

- 1). The relative temperature and humidity range are as below sketch, 90%RHMax.($T_a \leq 40^\circ\text{C}$).
- 2). The maximum wet bulb temperature $\leq 39^\circ\text{C}$ ($T_a > 40^\circ\text{C}$) and without dewing.
- 3). If you use the product in a environment which over the definition of temperature and humidity too long to effect the result of eye-etching.
- 4). The life time of the lamp is related to the current of the lamp, so please according to the description of the “(b) backlight” on page 7.
- 5). Test Condition: IEC 1000-4-2 VESDt: Contact discharge to input connector; VESDc: Contact discharge to module
- 6). If you operate the product in normal temperature range, the center surface of panel should be under 60°C .
- 7). When lamp current is out of the absolute maximum range, the life will fall rapidly or shown unusual sign.
IL min 2mA only for test only, but we can't guarantee the lifetime and performance.
- 8). Delay lighting testing needs the volt above start voltage Vrms. Before the procedure tube needs typical lighting for 1 minute and stay in the temperature $25 \pm 2^\circ\text{C}$ for 24 hours and then testing in the same condition in dark room.

Title : CLAA220WA01 Technical Specification

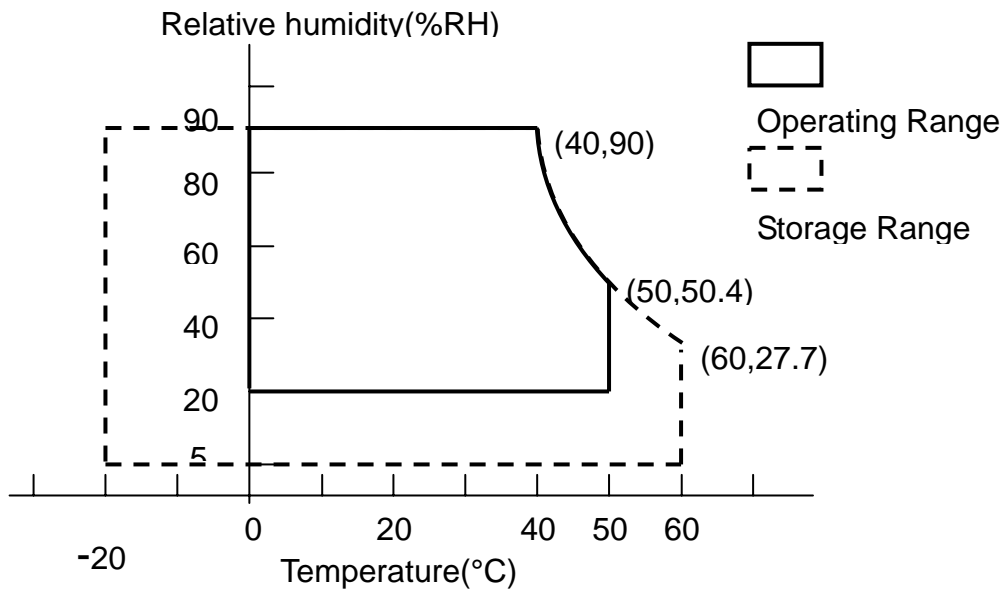

3. ELECTRICAL CHARACTERISTICS

(1).TFT-LCD

Ta=25°C

ITEM	SYMBOL	MIN	TYP	MAX	UNIT	REMARK	
Power Supply Voltage for LCD	VCC	4.5	5.0	5.5	V	*1)	
Power Supply Current for LCD	ICC	--	900	1500	mA	*2)	
Permissive Ripple Voltage for Logic	VRP	--	--	100	mVp-p	VCC=5.0V	
Differential Resistance	Zm	90	100	110	Ω		
LVDS: IN+ , IN-	The same motion input Voltage	VCM	1.125	1.25	1.375	V	*3)
	Differential input Voltage	VID	250	350	450	mV	
	High electric potential threshold voltage	VTH	-	-	100	mV	
	Low electric potential threshold voltage	VTL	-100	-	-	mV	
LCDInrush Current	Inrush	-	-	3	A	*4)	
Power consumption	P	-	4.5	7.5	W	*2)	

Title : CLAA220WA01 Technical Specification

[Note]

*1) Power、data sequence

- | | | |
|-----------------------------------|------------------------------------|--------------------|
| $0.5\text{ms} < t1 < 10\text{ms}$ | $t4 > 200\text{ms}$ | $t7 > 1\text{sec}$ |
| $0 < t2 < 50\text{ms}$ | $0 < t5 < 50\text{ms}$ | |
| $t3 > 250\text{ms}$ | $0.01\text{ms} < t6 < 10\text{ms}$ | |

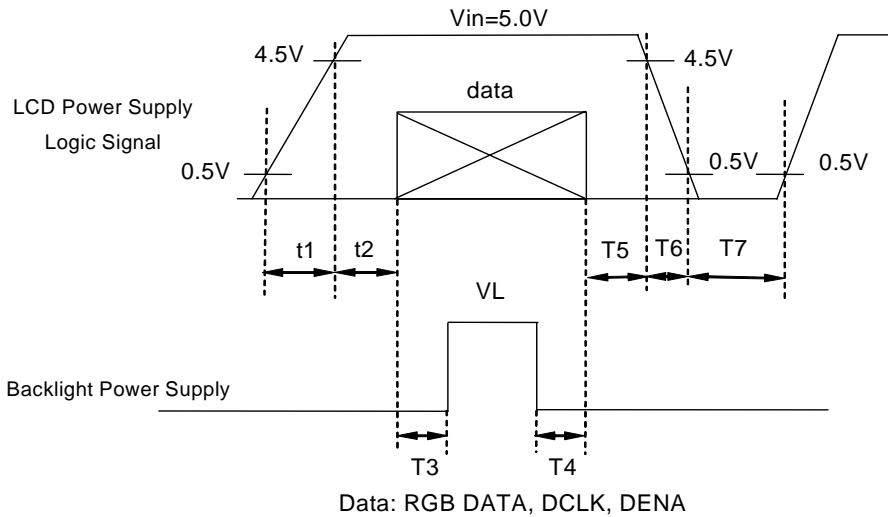

VCC-dip conditions:

- (1) When $3.6\text{V} \leq V_{cc}(\text{min}) < 4.5\text{V}$: $t_d \leq 10\text{ms}$
- (2) When $V_{cc} < 3.6\text{V}$, VCC-dip conditions should also follow the VCC-turn-on conditions.

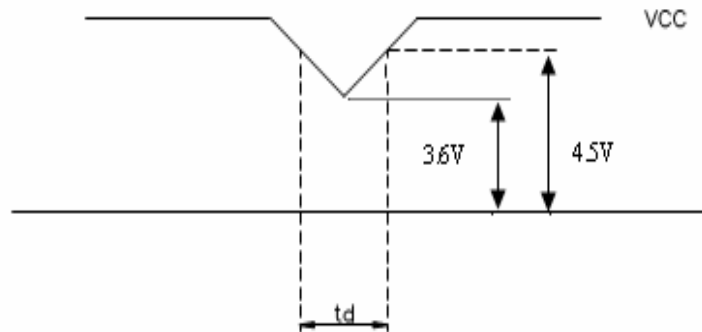

2). Typical value is measured when displaying horizontal gray scale line pattern:

64 gray level, 1680 line mode

$V_{CC}=5.0\text{V}$, $f_H=65\text{kHz}$, $f_V=60\text{Hz}$, $f_{CLK}=73.5\text{MHz}$

Title : CLAA220WA01 Technical Specification

3).LVDS Signal definition:

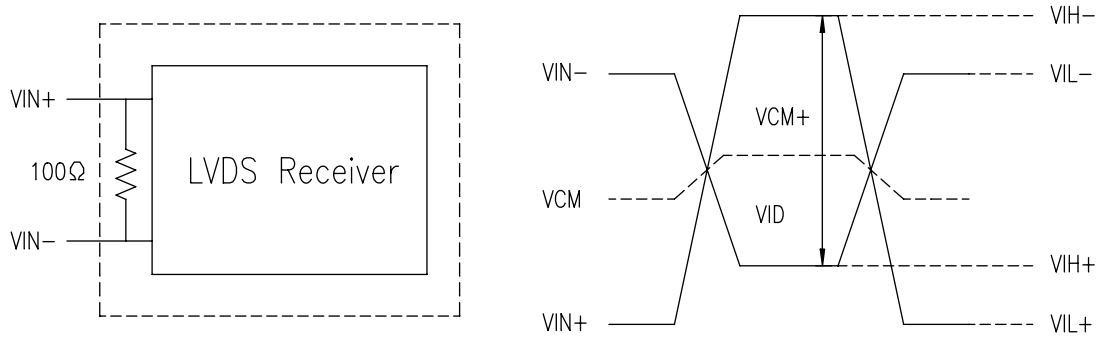

VIN+ : Positive differential DATA & CLK Input

VIN- : Negative differential DATA & CLK Input

4).Irush Measurement Condition

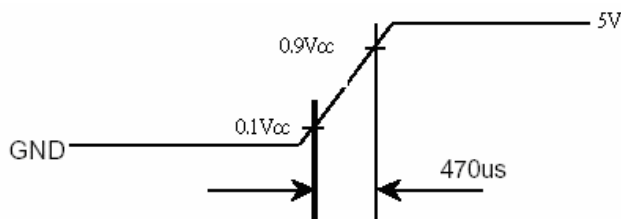
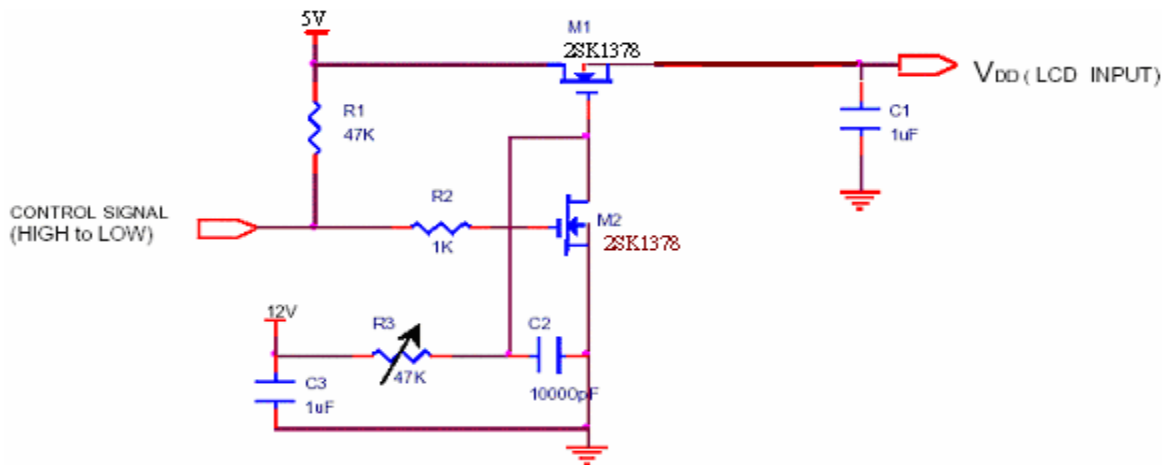

Title : CLAA220WA01 Technical Specification

(2).Backlight

1. Electrical specification

ITEM		SYMBOL	MIN	TYP	MAX	UNIT	REMARK
B/L Voltage	Delta	VL	729	810	891	Vrms	IL=7.0mA Ta=25°C
	STI	VL	792	880	968	Vrms	
B/L Current		IL	6.5	7.0	7.5	mArms	*1) Ta=25°C
B/L operating current		ILO	3	7.0	7.5	mArms	*1) Ta=25°C
B/L power consumption		WL	—	24.6	29.0	W	IL=7.0mA Ta=25°C
Inverter Frequency		FI	40	50	60	kHz	*2) Ta=25°C
Starting Lamp Voltage	Delta	VS	—	—	1850	Vrms	Ta=0°C
			—	—	1650	Vrms	Ta=25°C
	STI	VS	—	—	1800	Vrms	Ta=0°C
			—	—	1400	Vrms	Ta=25°C

2. Lamp life time

ITEM		ILO at 3.0 mA	ILO at 7.0 mA	ILO at 8.0 mA	UNIT	REMARK
	Delta	Min. 50,000	Min. 40,000	Min. 30,000		
	STI	Min. 45,000	Min. 40,000	Min. 30,000		
Rated time (turn on/off)		—	Min.100,000	—	time	*4)

[Note] Inverter vendor: Sumida, model: IV50167/T

If the waveform of light up-driving is asymmetric, the distribution of mercury inside the lamp tube will become unequally or will deplete the Ar gas in it. Then it may cause the abnormal phenomenon of lighting-up. Therefore, designers have to try their best to fulfill the conditions under the inverter designing-stage as below:

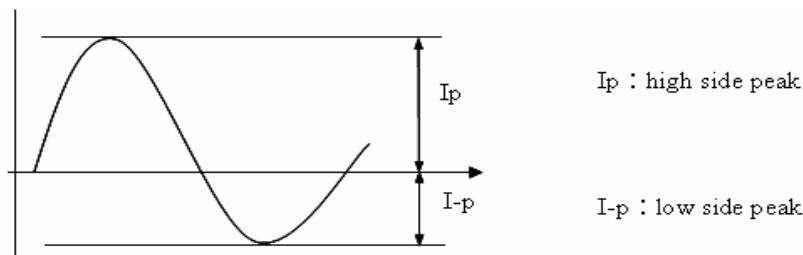

A : The degrees of unbalance = $|I_p - I-p| / I_{rms} \times 100 (\%)$

B : The ratio of wave height = $I_p \text{ (or } I-p) / I_{rms}$

Title : CLAA220WA01 Technical Specification

1) Lamp Current measurement method (The current meter is inserted in cold line)

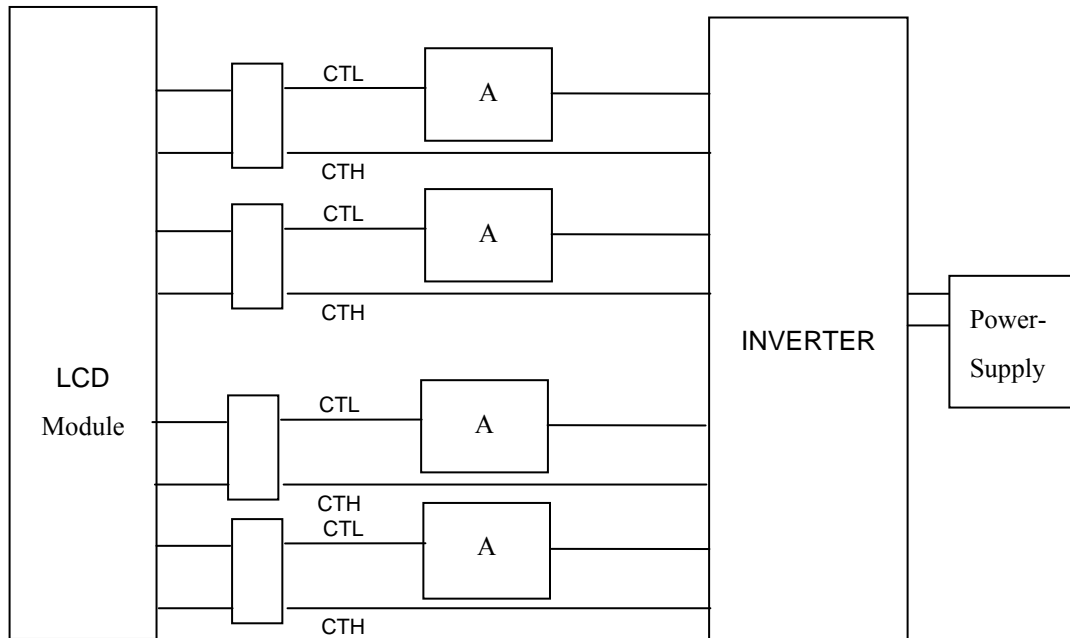

- 2) a. Frequency in this range can make the characteristics of electric and optics maintain in +/- 10% except color coordinates.
- b. Frequency in 50~60kHz can make characteristics of electric and optics better.
- c. Frequency in 45~80kHz won't damage the lifetime and reliability of lamp.
- d. Lamp frequency of inverter may produce interference with horizontal(or vertical) synchronous frequency, and this may cause horizontal beat on the display. Therefore, please adjust lamp frequency, and keep inverter as far from module as possible or use electronic shielding between inverter and module to avoid the interference.
- 3) Definition of the lamp life time :
 - a. Luminance (L) under 50% of specification.
 - b. Starting Lamp Voltage: over 130% of the initial value. Ta=25°C
- 4) The condition of Turn-on and Turn-off operation is as below:
 - a. Lamp current is 7.0mA
 - b. Frequency is 10 sec.(on)/10 sec.(off)
 - c. Repeat it for 100 thousand times
 - d. The lamp hue variation must smaller than 0.03
 - e. It should not have motion fail when starting lamp voltage is lower than 130% of the initial value.
- 5) For keeping good lighting situation ,when design the inverter ,it must be considered that the voltage large than starting lamp voltage.
- 6) $WL = IL \times VL \times 4 \circ$ (IL=7mA , Ta=25°C)

Title : CLAA220WA01 Technical Specification

4. INTERFACE PIN CONNECTION

(1) CN1

Outlet connector: FI-XB30SSRL-HF16 (JAE) (or equivalent)

PIN NO.	REMARK	FUNCTION
1	RXO0-	minus signal of odd channel 0(LVDS)
2	RXO0+	plus signal of odd channel 0(LVDS)
3	RXO1-	minus signal of odd channel 1(LVDS)
4	RXO1+	plus signal of odd channel 1(LVDS)
5	RXO2-	minus signal of odd channel 2(LVDS)
6	RXO2+	plus signal of odd channel 2(LVDS)
7	GND	GND
8	RXOC-	minus signal of odd clock channel (LVDS)
9	RXOC+	plus signal of odd clock channel (LVDS)
10	RXO3-	minus signal of odd channel 3(LVDS)
11	RXO3+	plus signal of odd channel 3(LVDS)
12	RXE0-	minus signal of even channel 0(LVDS)
13	RXE0+	plus signal of even channel 0(LVDS)
14	GND	GND
15	RXE1-	minus signal of even channel 1(LVDS)
16	RXE1+	plus signal of even channel 1(LVDS)
17	GND	GND
18	RXE2-	minus signal of even channel 2(LVDS)
19	RXE2+	plus signal of even channel 2(LVDS)
20	RXEC-	minus signal of even clock channel (LVDS)
21	RXEC+	plus signal of even clock channel (LVDS)
22	RXE3-	minus signal of even channel 3(LVDS)
23	RXE3+	plus signal of even channel 3(LVDS)
24	GND	GND
25	NC	NC
26	NC	Test pin (Can't connect to GND)
27	NC	NC
28	VCC	Power supply input voltage(5.0 V)
29	VCC	Power supply input voltage(5.0 V)
30	VCC	Power supply input voltage(5.0 V)

- 1) Keep the NC Pin and don't connect it to GND or other signals.
- 2) GND Pin must connect to the ground, don't let it be a vacant pin.

(2) CN2, 3, 4, 5 (BACKLIGHT)

CN2、CN3、CN4、CN5 : BHSR-02VS-1 (JST)

<Mating connector: SM02B-BHSS-1-TB (JST)>

Title : CLAA220WA01 Technical Specification

No.	Pin	Symbol	Description
CN2	1	HV	High Voltage Output for CCFL Lamp 1
	2	LV	Low Voltage Output for CCFL Lamp 1
CN3	1	HV	High Voltage Output for CCFL Lamp 2
	2	LV	Low Voltage Output for CCFL Lamp 2
CN4	1	HV	High Voltage Output for CCFL Lamp 3
	2	LV	Low Voltage Output for CCFL Lamp 3
CN5	1	HV	High Voltage Output for CCFL Lamp 4
	2	LV	Low Voltage Output for CCFL Lamp 4

Title : CLAA220WA01 Technical Specification

5. INTERFACE TIMING

(1) Timing Characteristic

ITEM		SYMBOL	MIN.	TYP.	MAX.	UNIT		
LCD Timing	DCLK	Freq.	f_{CLK}	61	73.5	83	MHz	
		Cycle	t_{CLK}	12	13.6	16.4	ns	
	DENA	Horizontal	Horizontal total time	t_H	880	1135	1300	t_{CLK}
			Horizontal effective time	t_{HA}	840	840	840	t_{CLK}
			Horizontal blank time	t_{HB}	40	295	460	t_{CLK}
		Vertical	Vertical frame Rate	Fr	55	60	75	Hz
			Vertical total time	t_V	1060	1080	1300	t_H
			Vertical effective time	t_{VA}	1050	1050	1050	t_H
			Vertical blank time	t_{VB}	10	30	250	t_H

[Note]

- *1) DENA (data enable) usually is positive
- *2) DCLK still inputs during blanking
- *3) LVDS transmitter IC : : NT71671-00033(NVT)
- *4) LVDS IC :

Receiver	Transmitter
DS90C384MTD(NS)	DS90C383MTD(NS)
SN75LVDS82(TI)	SN75LVDS83(TI)

- *5) DE mode only
- *6) It maybe cause flicker at 55Hz

(2).Timing Chart

a. Horizontal Signal

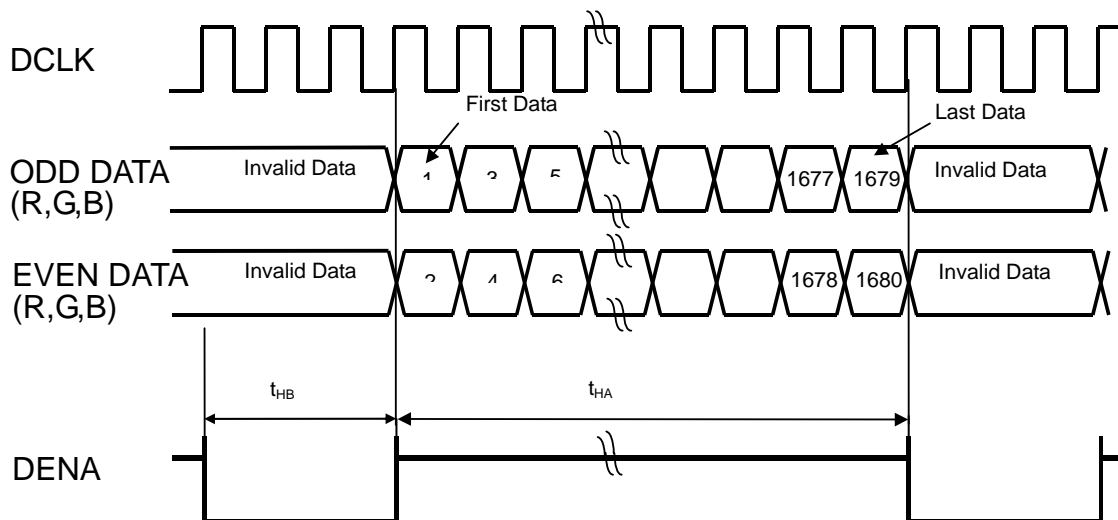

Title : CLAA220WA01 Technical Specification

b. Vertical Signal

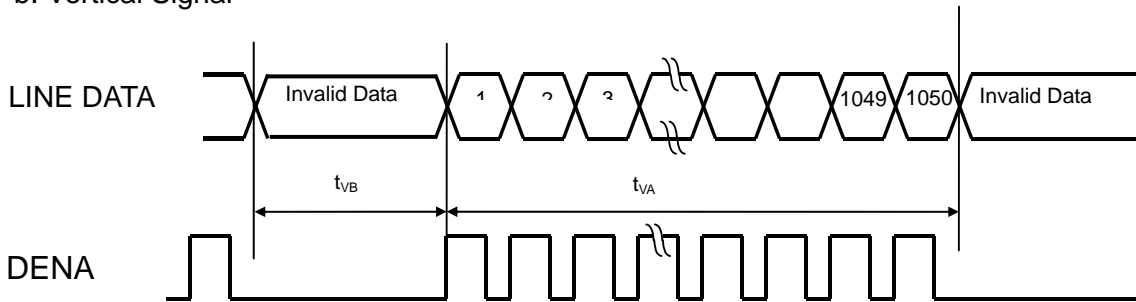

(3).LVDS Data

For 6Bit+Hi-FRC

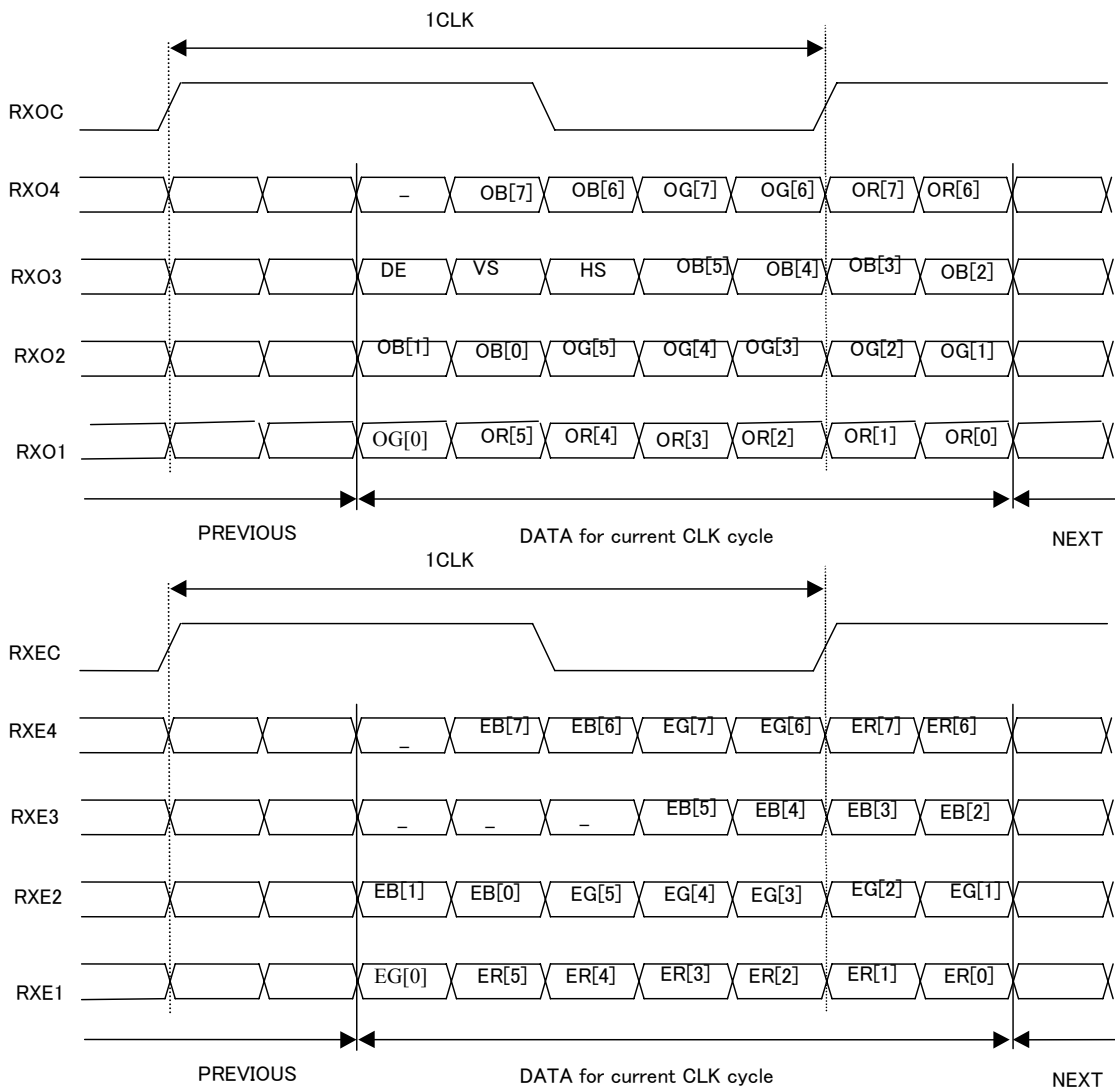

Title : CLAA220WA01 Technical Specification

Color Data Assignment

COLOR	INPUT DATA	R DATA								G DATA								B DATA							
		R7	R6	R5	R4	R3	R2	R1	R0	G7	G6	G5	G4	G3	G2	G1	G0	B7	B6	B5	B4	B3	B2	B1	B0
		MSB						LSB	MSB							LSB	MSB								LSB
BASIC COLOR	BLACK	0	0	0	0	0	0	0	0	0	0	0	0	0	0	0	0	0	0	0	0	0	0	0	
	RED(255)	1	1	1	1	1	1	1	1	0	0	0	0	0	0	0	0	0	0	0	0	0	0	0	
	GREEN(255)	0	0	0	0	0	0	0	0	1	1	1	1	1	1	1	0	0	0	0	0	0	0	0	
	BLUE(255)	0	0	0	0	0	0	0	0	0	0	0	0	0	0	0	1	1	1	1	1	1	1	1	
	CYAN	0	0	0	0	0	0	0	0	1	1	1	1	1	1	1	1	1	1	1	1	1	1	1	
	MAGENTA	1	1	1	1	1	1	1	1	0	0	0	0	0	0	0	1	1	1	1	1	1	1	1	
	YELLOW	1	1	1	1	1	1	1	1	1	1	1	1	1	1	1	0	0	0	0	0	0	0	0	
	WHITE	1	1	1	1	1	1	1	1	1	1	1	1	1	1	1	1	1	1	1	1	1	1	1	
RED	RED(0)	0	0	0	0	0	0	0	0	0	0	0	0	0	0	0	0	0	0	0	0	0	0	0	
	RED(1)	0	0	0	0	0	0	0	1	0	0	0	0	0	0	0	0	0	0	0	0	0	0	0	
	RED(2)	0	0	0	0	0	0	1	0	0	0	0	0	0	0	0	0	0	0	0	0	0	0	0	
	RED(254)	1	1	1	1	1	1	1	0	0	0	0	0	0	0	0	0	0	0	0	0	0	0	0	
	RED(255)	1	1	1	1	1	1	1	1	0	0	0	0	0	0	0	0	0	0	0	0	0	0	0	
GREEN	GREEN(0)	0	0	0	0	0	0	0	0	0	0	0	0	0	0	0	0	0	0	0	0	0	0	0	
	GREEN(1)	0	0	0	0	0	0	0	0	0	0	0	0	0	0	1	0	0	0	0	0	0	0	0	
	GREEN(2)	0	0	0	0	0	0	0	0	0	0	0	0	0	1	0	0	0	0	0	0	0	0	0	
	GREEN(254)	0	0	0	0	0	0	0	0	1	1	1	1	1	1	1	0	0	0	0	0	0	0	0	
	GREEN(255)	0	0	0	0	0	0	0	0	1	1	1	1	1	1	1	0	0	0	0	0	0	0	0	
BLUE	BLUE(0)	0	0	0	0	0	0	0	0	0	0	0	0	0	0	0	0	0	0	0	0	0	0	0	
	BLUE(1)	0	0	0	0	0	0	0	0	0	0	0	0	0	0	0	0	0	0	0	0	0	0	1	
	BLUE(2)	0	0	0	0	0	0	0	0	0	0	0	0	0	0	0	0	0	0	0	0	0	1	0	
	BLUE(254)	0	0	0	0	0	0	0	0	0	0	0	0	0	0	0	1	1	1	1	1	1	1	0	
	BLUE(255)	0	0	0	0	0	0	0	0	0	0	0	0	0	0	0	1	1	1	1	1	1	1	1	

- [Note] 1) Definition of gray scale: Color (n): n indicates gray scale level; higher n means brighter level.
 2) Data: 1-High, 0-Low.
 3) For odd & even data also.

(4). Color Data Distribution

D(1,1)	D(2,1)	..	D(X,1)	..	D(1679,1)	D(1680,1)
D(1,2)	D(2,2)	..	D(X,2)	..	D(1679,2)	D(1680,2)
..	..	+	..	+
D(1,Y)	D(2,Y)	..	D(X,Y)	..	D(1679,Y)	D(1680,Y)
..	..	+	..	+
D(1,1049)	D(2,1049)	..	D(X,1049)	..	D(1679,1049)	D(1680,1049)
D(1,1050)	D(2,1050)	..	D(X,1050)	..	D(1679,1050)	D(1680,1050)

Title : CLAA220WA01 Technical Specification

6. BLOCK DIAGRAM

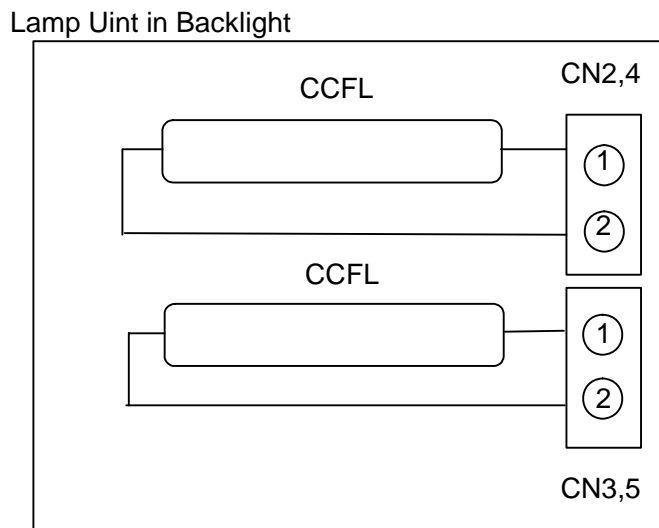
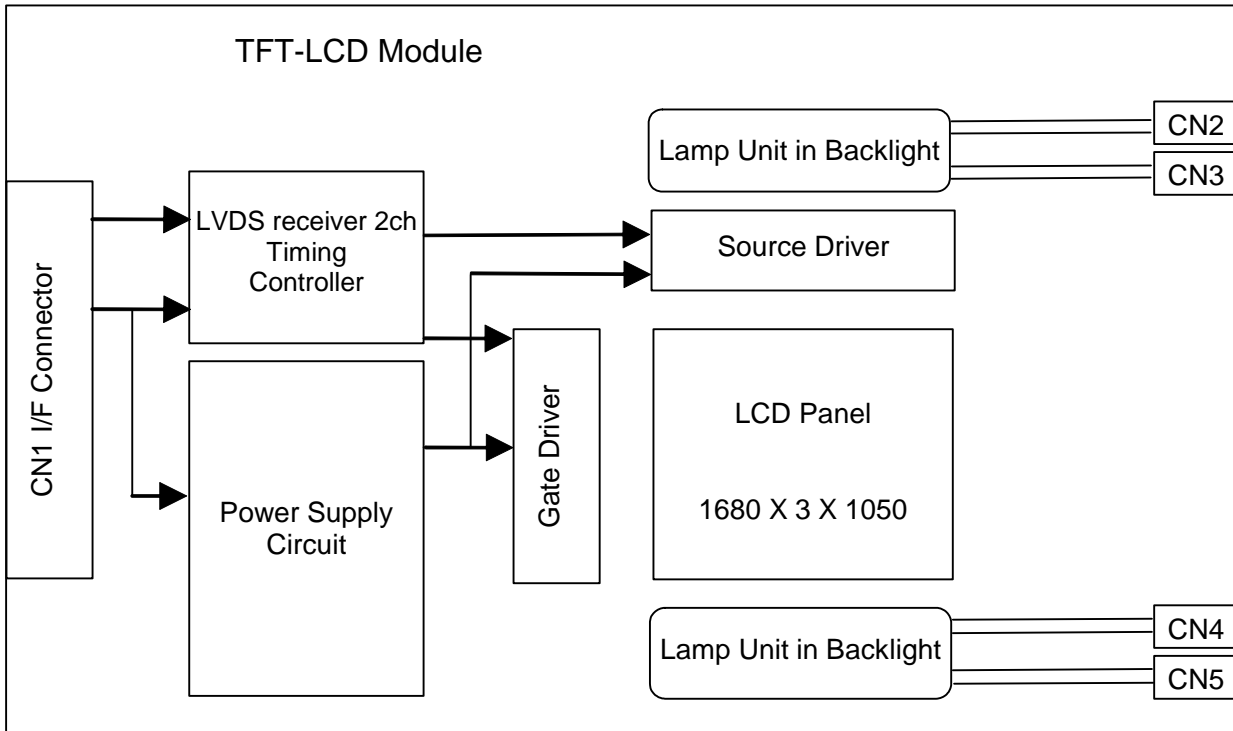

Title : CLAA220WA01 Technical Specification

(2)Rear side (Tolerance is $\pm 0.5\text{mm}$ unless noted)

[Unit: mm]

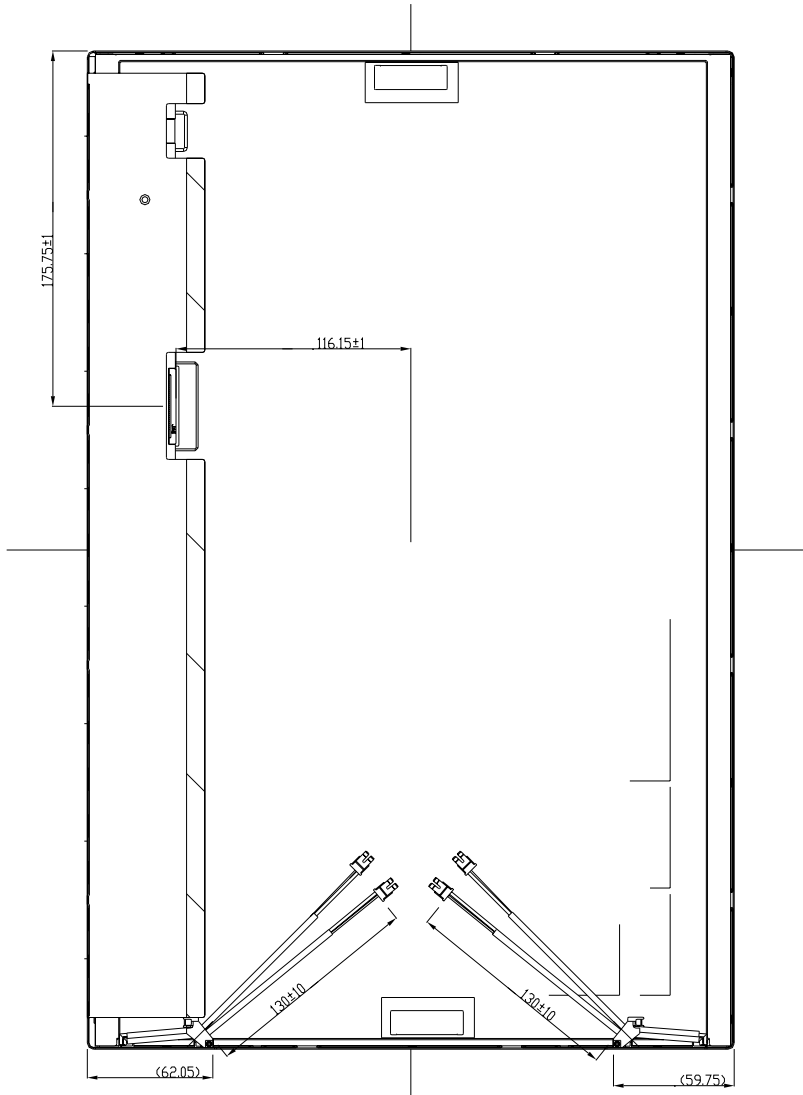

Title : CLAA220WA01 Technical Specification

8. OPTICAL CHARACTERISTICS

Ta=25°C , VCC=5.0V

ITEM	SYMBOL	CONDITION	MIN.	TYP.	MAX.	UNIT	REMARK	
Contrast (CEN)	CR	$\theta = \psi = 0^\circ$	800	1000	--	--	*1)	
Luminance (CEN)	L	$\theta = \psi = 0^\circ$	250	300	--	cd/m ²	*2)	
9P Uniformity	ΔL	$\theta = \psi = 0^\circ$	75	--	--	%	*2)	
Response Time	Tr+Tf	$\theta = \psi = 0^\circ$	--	5	8	ms	*4)	
Cross talk	CT	$\theta = \psi = 0^\circ$	--	--	1	%	*5)	
View angle	Horizontal	ψ	$CR \geq 10$	150	170	--	Deg.	*3)
	Vertical	θ		140	160	--	Deg.	
	Horizontal	ψ	$CR \geq 5$	150	170	--	Deg.	
	Vertical	θ		150	170	--	Deg.	
Color Coordinates	White	x	$\theta = \psi = 0^\circ$	0.283	0.313	0.343	Color Coordinates	*2)
		y		0.299	0.329	0.359		
	Red	x		0.625	0.655	0.685		
		y		0.299	0.329	0.359		
	Green	x		0.246	0.276	0.306		
		y		0.587	0.617	0.647		
	Blue	x		0.114	0.144	0.174		
y		0.058	0.088	0.118				
Gamut	CG	$\theta = \psi = 0^\circ$	70	72		%		
Gamma	γ	VESA	2.0	2.2	2.4	--	*6)	

[Note]

Color coordinate and color gamut are measured by CS-1000, and all the other items are measured by BM-5A(TOPCON). All these items are measured under the dark room condition (no ambient light).

Measurement Condition: IL=7.0mA × 4

Inverter: Sumida, model: IV50167/T — — , Frequency=50kHz.

Definition of these measurement items is as follows:

1) Definition of Contrast Ratio

CR=ON (White) Luminance/OFF (Black) Luminance

2) Definition of Luminance and Luminance uniformity

Central luminance: The white luminance is measured at the center position “5” on the screen, see Fig.1 below. And the measure time is 30 min after discharged.

Title : CLAA220WA01 Technical Specification

9P Luminance (AVG): The white luminance is measured at measuring points 1 to 9, see Fig.1 below.

9P Uniformity: $\Delta L = (L_{MIN} / L_{MAX}) \times 100\%$

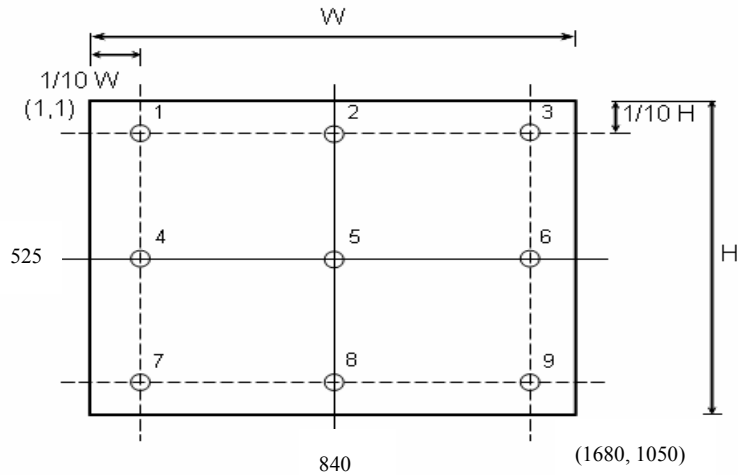

3).Definition of Viewing Angle (θ, ψ):

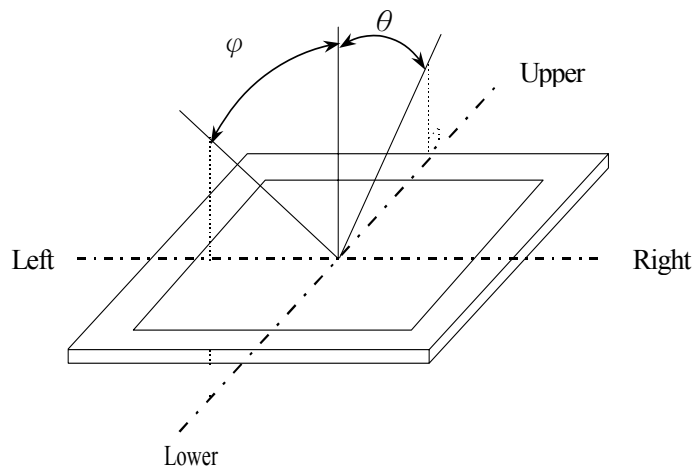

4) Definition of Response Time:

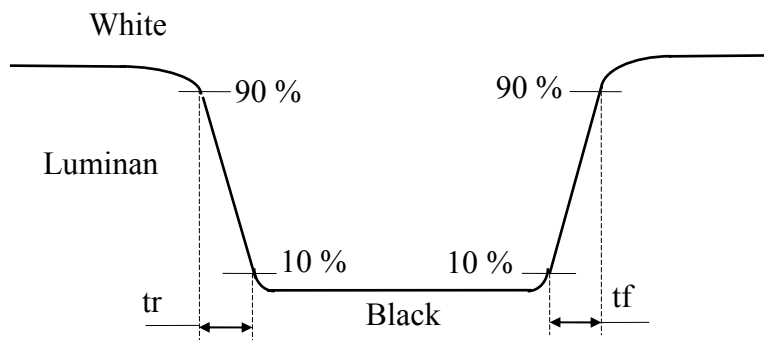

Title : CLAA220WA01 Technical Specification

5) Definition of crosstalk:

$$CT = | Y_B - Y_A | / Y_A \times 100 (\%)$$

Y_A : The luminance of measured position at pattern A

Y_B : The luminance of measured position at pattern B with Gray level 0

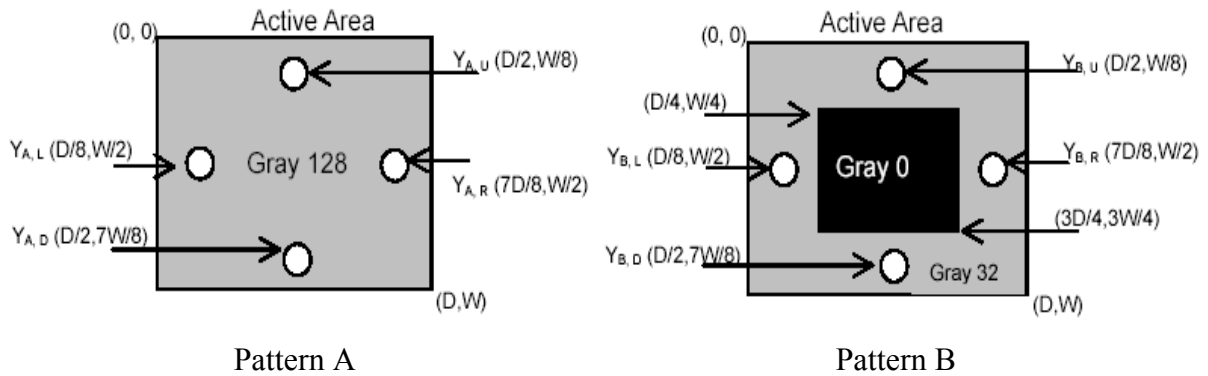

6) Definition of Gamma (γ), follow VESA standard sampling every 16 gray level(0,16,32,.....224,240,255)

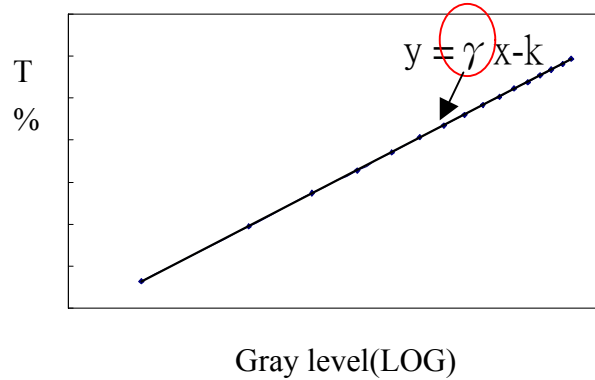

Title : CLAA220WA01 Technical Specification

9. RELIABILITY TEST CONDITIONS

(1) Temperature and Humidity

TEST ITEMS	CONDITIONS
HIGH TEMPERATURE HIGH HUMIDITY OPERATION	50°C ; 90%RH; 240h (No condensation)
HIGH TEMPERATURE HIGH HUMIDITY STORAGE	60°C ; 90%RH;48h (No condensation)
HIGH TEMPERATURE OPERATION	50°C ; 240h
HIGH TEMPERATURE STORAGE	60°C ; 240h
LOW TEMPERATURE OPERATION	0°C ; 240h
LOW TEMPERATURE STORAGE	-20°C ; 240h
THERMAL SHOCK	BETWEEN -20°C(1hr)AND 60°C(1hr); 100 CYCLES

(2) Shock & Vibration

ITEMS	CONDITIONS
SHOCK (NON-OPERATION)	Shock level:980m/s ² (100G) Waveform: half sinusoidal wave, 2ms Number of shocks: one shock input in each direction of three mutually perpendicular axes for a total of six shock inputs
VIBRATION (NON-OPERATION)	Vibration level: 9.8m/s ² (1.0G) zero to peak Waveform: sinusoidal Frequency range: 5 to 500 Hz Frequency sweep rate: 0.5 octave/min Duration: one sweep from 5 to 500Hz in each of three mutually perpendicular axis(each x,y,z axis: 1 hour, total 3 hours)

(3) ESD

POSITION	CONDITION(MDL turn off)
Connector	1. 200 pF , 0 Ω , ±250 V 2. contact mode for each pin
Module	1. 150 pF , 330 Ω , ±15K V 2. Air mode, test 25 times for each test point 3. Contact mode, 25 times for each test point

(4) Low Pressure test

TEST ITEM	CONDITION
Low Pressure test(storage)	260HPa (30000 ft.) ; 24 Hr

Title : CLAA220WA01 Technical Specification

(5) Judgment standard

The judgment of the above test should be made as follow:

Pass: Normal display image with no obvious non-uniformity and no line defect. Partial transformation of the module parts should be ignored.

Fail: No display image, obvious non-uniformity, or line defects.

Title : CLAA220WA01 Technical Specification

10. PACKING SPECIFICATION

(1)Packing

- 6 LCD TV modules (max.) / 1 Box
- 24 box (max.) / 1 pallet
- Box dimensions: 585(L)×260(W)×440(H)
- Weight: approximately 20Kg (6 modules per box)

(2)Packing Method

Figure (a) and (b) are the packing method

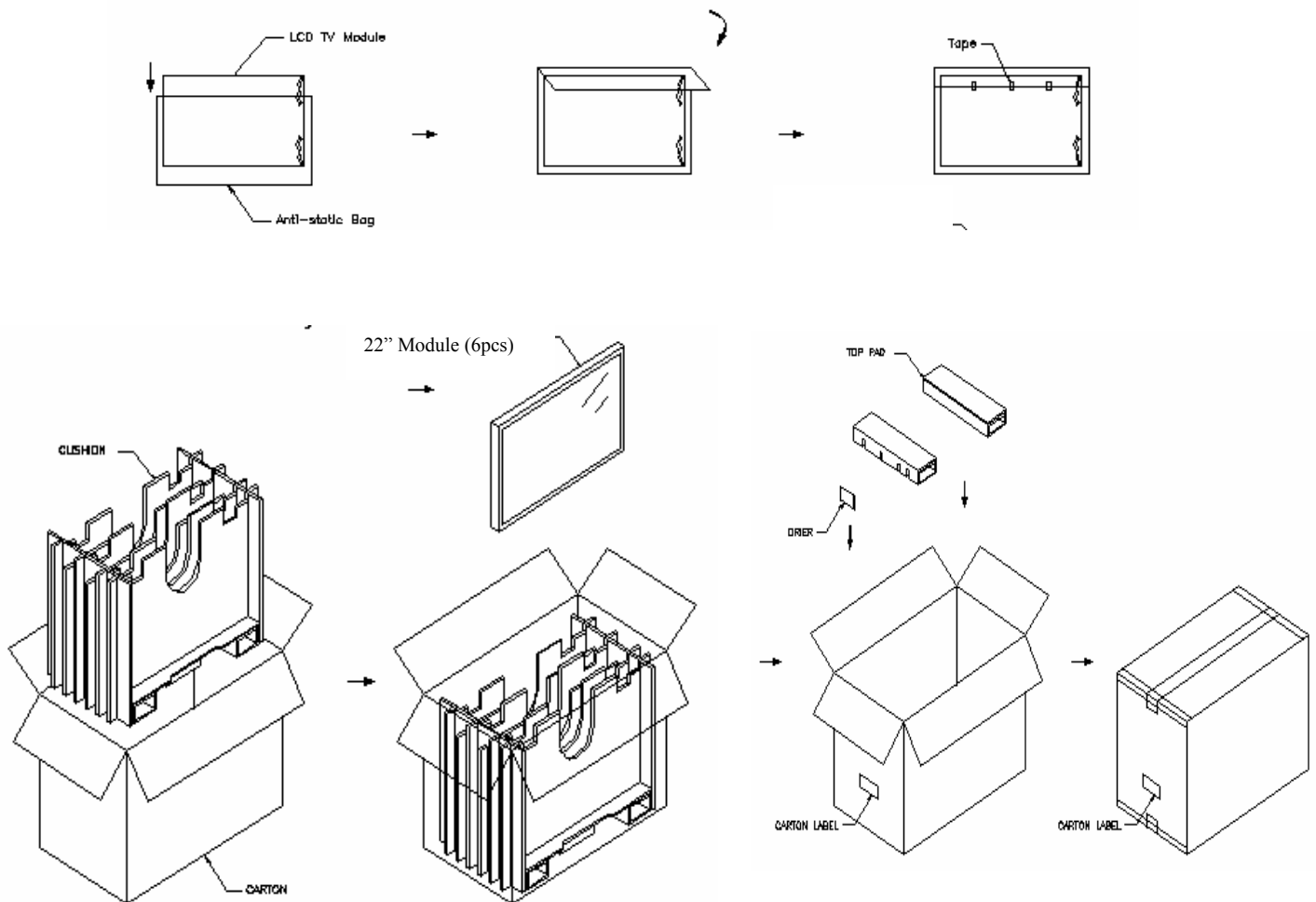

Figure (a) packing method

Title : CLAA220WA01 Technical Specification

Cover Protector: L1300 × 50 × 50mm
Pallet: 1200(L) × 1100(W) × 130(H) mm
Top/Bottom Cap: L1200 × 1100 × 130mm
Pallet stack: 1200(L) × 1100(W) × 1470(H) mm
Gross Weight: 490Kg(±2Kg)

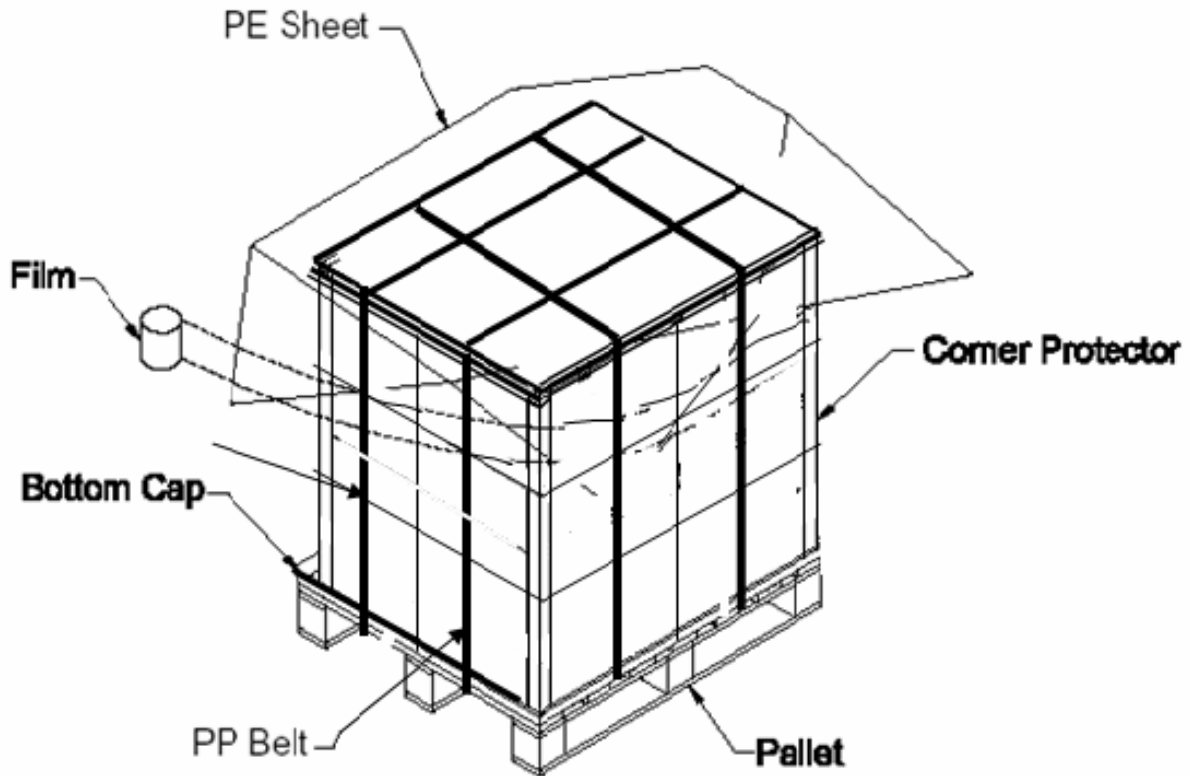

Figure (b) packing method

Title : CLAA220WA01 Technical Specification

11. HANDLING PRECAUTIONS FOR TFT-LCD MODULE

Please pay attention to the followings in handling- TFT-LCD products;

1. ASSEMBLY PRECAUTION

- (1) Please use the mounting hole on the module side in installing and do not beading or wrenching LCD in assembling. And please do not drop, bend or twist LCD module in handling.
- (2) Please design display housing in accordance with the following guide lines.
 - (2.1) Housing case must be destined carefully so as not to put stresses on LCD all sides and not to wrench module. The stresses may cause non-uniformity even if there is no non-uniformity statically.
 - (2.2) Keep sufficient clearance between LCD module back surface and housing when the LCD module is mounted. Approximately 1.0 mm of the clearance in the design is recommended taking into account the tolerance of LCD module thickness and mounting structure height on the housing.
 - (2.3) When some parts, such as, FPC cable and ferrite plate, are installed underneath the LCD module, still sufficient clearance is required, such as 0.5mm. This clearance is, especially, to be reconsidered when the additional parts are implemented for EMI countermeasure.
 - (2.4) Design the inverter location and connector position carefully so as not to give stress to lamp cable, or not to interface the LCD module by the lamp cable.
 - (2.5) Keep sufficient clearance between LCD module and the others parts, such as inverter and speaker so as not to interface the LCD module. Approximately 1.0mm of the clearance in the design is recommended.
- (3) Please do not push or scratch LCD panel surface with any-thing hard. And do not soil LCD panel surface by touching with bare hands. (Polarizer film, surface of LCD panel is easy to be flawed.)
- (4) Please do not press any parts on the rear side such as source TCP, gate TCP, control circuit board and FPCs during handling LCD module. If pressing rear part is unavoidable, handle the LCD module with care not to damage them.
- (5) Please wipe out LCD panel surface with absorbent cotton or soft cloth in case of it being soiled.
- (6) Please wipe out drops of adhesives like saliva and water on LCD panel surface immediately. They might damage to cause panel surface variation and color change.
- (7) Please do not take a LCD module to pieces and reconstruct it. Resolving and

Title : CLAA220WA01 Technical Specification

reconstructing modules may cause them not to work well.

- (8) Please do not touch metal frames with bare hands and soiled gloves. A color change of the metal frames can happen during a long preservation of soiled LCD modules.
- (9) Please pay attention to handling lead wire of backlight so that it is not tugged in connecting with inverter.

2. OPERATING PRECAUTIONS

- (1) Please be sure to turn off the power supply before connecting and disconnecting signal input cable.
- (2) Please do not change variable resistance settings in LCD module. They are adjusted to the most suitable value. If they are changed, it might happen LCD does not satisfy the characteristics specification.
- (3) Please consider that LCD backlight takes longer time to become stable of radiation characteristics in low temperature than in room temperature.
- (4) A condensation might happen on the surface and inside of LCD module in case of sudden change of ambient temperature.
- (5) Please pay attention to displaying the same pattern for very long time. Image might stick on LCD. If then, time going on can make LCD work well.
- (6) Please obey the same caution descriptions as ones that need to pay attention to ordinary electronic parts.

3. PRECAUTIONS WITH ELECTROSTATICS

- (1) This LCD module use CMOS-IC on circuit board and TFT-LCD panel, and so it is easy to be affected by electrostatics. Please be careful with electrostatics by the way of your body connecting to the ground and so on.
- (2) Please remove protection film very slowly on the surface of LCD module to prevent from electrostatics occurrence.

4. STORAGE PRECAUTIONS

- (1) When you store LCDs for a long time, it is recommended to keep the temperature between 0°C ~40°C without the exposure of sunlight and to keep the humidity less than 90%RH.
- (2) Please do not leave the LCDs in the environment of high humidity and high temperature such as 60°C 90%RH.

Title : CLAA220WA01 Technical Specification

(3) Please do not leave the LCDs in the environment of low temperature; below -20°C.

5. SAFETY PRECAUTIONS

- (1) When you waste LCDS, it is recommended to crush damaged or unnecessary LCDs into pieces and wash them off with solvents such as acetone and ethanol, which should later be burned.
- (2) If any liquid leaks out of a damaged-glass cell and comes in contact with the hands, wash off thoroughly with soap and water.

6. OTHERS

- (1) A strong incident light into LCD panel might cause display characteristics' changing inferior because of polarizer film, color filter, and other materials becoming inferior. Please do not expose LCD module direct sunlight and strong UV rays.
- (2) Please pay attention to a panel side of LCD module not to contact with other materials in preserving it alone.
- (3) For the packaging box, please pay attention to the followings:
 - (3.1) Packaging box and inner case for LCD are designed to protect the LCDs from the damage or scratching during transportation. Please do not open except picking LCDs up from the box.
 - (3.2) Please do not pile them up more than 5 boxes. (They are not designed so.) And please do not turn over.
 - (3.3) Please handle packaging box with care not to give them sudden shock and vibrations. And also please do not throw them up.
 - (3.4) Packing box and inner case for LCDs are made of cardboard. So please pay attention not to get them wet. (Such like keeping them in high humidity or wet place can occur getting them wet.)