

Threat Effects and Trade: Wage Discipline through Product Market Competition

Arindrajit Dube* and Sanjay G. Reddy†

October 6th 2006

Abstract

We present a formal model of the effect of heightened product market competition induced by trade liberalization on the distribution of income between profits and wages. Integration increases the employment cost of wage demands, thereby decreasing bargained wages and the share of rents accruing to workers. This effect is amplified because of the existence of strategic complementarities which bring about a race to the bottom. Trade-liberalization induced wage discipline mitigates the impact of increased competition on firm rents, and may even raise profits.

Keywords: Trade, Bargaining, Rent-Sharing, Income Distribution, Threat Effects

JEL Codes: F12,F15,F16, D31, D33, J3, J5

*University of California at Berkeley; adube@berkeley.edu

†Barnard College, Columbia University; sr793@columbia.edu

1. INTRODUCTION

It is often argued that one of the reasons that trade produces gains is that it enhances competition among firms. We show that a consequence of this pro-competitive effect of trade is to change systematically the distribution of income between factors of production – in particular to reduce relative returns to labor and to increase relative returns to capital – in the affected industries. We bring together two otherwise unconnected literatures, on the impact of trade on competition and on the impact of trade on the distribution of income among factors of production.

We present a framework for analyzing the effect of increased product market competition on the process of bargaining between workers and employers. We demonstrate that increased competition between firms can implicitly raise the employment cost of wage increases and thereby cause workers (who value both objectives) to moderate their wage demands. This wage disciplining effect causes the employers' share of available surplus to shift in their favor, and can be sufficiently large that it may cause profits to rise, despite diminished per-firm surpluses resulting from increased competition.

This result helps to illuminate why trade may lead to reductions in wages despite movements in relative product prices which are too low or contrary in direction compared with those required in conventional theories in order for trade to have such an effect. It also explains why such an effect may be present in both developed countries and developing countries, contrary to the conclusions of conventional models (in which the impact of trade on wages depends on the relative abundance of factors of production in a country). Indeed the model presented requires no trade to occur at all in order for the *threat* of trade (i.e.

its implicit pro-competitive effect) to have distributional effects. The model we develop provides a theoretical rationale for recent findings concerning the apparent association of trade with wage deterioration in both poor countries and rich countries.

Rodrik (1997) raises arguments closely related to that of this paper. He points out that trade-induced increased elasticities of labor demand can influence the well-being of workers. Rodrik suggests that trade-induced heightened elasticities of labor demand can cause moderation of wage demands by workers. We attempt rigorously to analyze this claim.

Specifically, we conclude that heightened product market competition as a result of trade liberalization can influence the distribution of income between profits and wages in at least four possible ways. The first mechanism is that increases in product market competition shrinks per-firm rents, and leads to a reduction in rents captured by workers in the form of wages (even if their share of rents remains constant). The second mechanism is that increases in product market competition can induce increases in elasticities of labor demand which cause workers at any enterprise to moderate their wage demands. The third mechanism is that competition and strategic complementarity in wage setting between workers further magnifies these wage reductions through a "strategic multiplier." The fourth mechanism is that the diminishing rents realized by workers can cause an endogenous decrease in the extent of worker organization, which in turn would reduce the ability of organized workers to establish high wages.

The principle that an increased elasticity of product demand tends to lead to an increase in the elasticity of a firm's demand for labor was first explicitly identified by Alfred Marshall in the *Principles of Economics*, and examined in a general setting by J. R. Hicks (1968, 1932).

This so-called Hicks-Marshall law of derived demand is supported by statistical evidence that labor demand elasticities are higher in contexts where product demand elasticities are also higher [See Ehrenberg and Smith (1997), Hamermesh (1993)]. This principle when combined with evidence that organized workers have some concern for employment as well as individual income [MaCurdy and Pencavel (1986), McDonald and Solow (1981)], and that contracts in which wages are set but firms are free to determine the level of employment are widespread, makes the degree of product market competition a key explanatory factor in determining wage bargains.¹

There exists considerable microeconomic evidence from developed countries that diminished per-firm rents induced by greater competition lower wages.² Although this evidence

¹ Organized workers exist whenever coalitions form within firms and exercise a degree of power. These organized workers may act as if exhibiting concern both for their own wages and for the level of employment of their fellow workers. In this sense, the "workers' objectives" might be thought of as a reduced form behavioral response which could reside in internal labor markets, norms, etc. The use of "organized workers" rather than "unions" through much of the paper is meant to assert that workers can have bargaining power within the firm even in the absence of unionization but it is not meant to deny that formal unions may be an especially important vehicle for workers to achieve their goals.

²This observation goes back to Dunlop (1950) and Slichter (1950), but has also received more recent support. It has been observed, for example, that in two different segments of the trucking industry in the United States (namely that for "full truckloads" and that for "less-than-truckloads") which have very different degrees of competitiveness (in the latter the largest four carriers accounted for 11 percent of revenues and in the former they accounted for 37 percent) the level of union wages was dramatically different (28.4 cents per mile vs. 35.8 cents per mile, and a union to non-union wage ratio of 1.23 vs. 1.34 respectively) [Belzer (1994, 1995), Ehrenberg and Smith (1997)]. An independent example involving the trucking industry is that deregulation is reported to have led to "substantial relative wage reductions for union truckers and much less wage response for non-union truckers following deregulation", a view that is interpreted as "consistent" with the judgment that wages respond to increased product market competition [Freeman and Katz (1991), See also Rose (1987)]. Similarly, when deregulation of the airline industry in the United States increased competition on many routes after 1978, there were substantial reductions in the wages of unionized pilots, as a result of requests for concessions by airlines which were accepted by unions. By 1987, the real earnings of pilots had fallen 17 percent below the levels in 1978, and the real earnings of airline mechanics had fallen by 13 percent [Card (1986, 1989), Johnson (1991)]. Abowd and Lemieux (1993) find that, instrumenting quasi-rents by import competition shocks, firm-level wage bargains are considerably influenced by product market competition. Blanchflower, Oswald and Sanfey (1996), using an un-balanced panel from the US manufacturing sector, find strong evidence of a rise in a sector's profitability leading to an increase in the level of wages in that sector over time. Blanchflower and Machin (1996) find limited support from establishment-level data for an impact of product market competition on wages in Britain and Australia. Christofides and Oswald (1992) find from Canadian labor contract data that real wages are an increasing function of profitability in an industry. Nickell, Vainomaki and Wadhvani (1994) similarly find evidence from a large sample of British manufacturing firms that a firm's market power has a positive impact on wages,

affirms the view that wages reflect an element of rent sharing, they leave important questions unanswered. In particular, they do not much illuminate whether rents are shared in constant proportions, or in a manner which is itself *endogenous* to the degree of product market competition (as argued in this paper). It is also interesting to note that none of these studies seem to have examined the impact of deregulation on the profitability of firms.

The heated debate on the relation between trade and wages in developed countries, which has sought explanations as to the causes of wage stagnation of unskilled workers in the last two decades, has often focused on the relative prices of goods and on measures of the extent of trade. The first focus arises from the fact that within the perfectly competitive setting of conventional international trade models, a necessary condition for real wages of workers in import-competing industries to fall is that the relative price of the goods they produce should fall. However empirical evidence of this condition is limited or lacking [see for example Bhagwati and Kusters (1994), Bhagwati (1998), Slaughter (1998, 2000), Krugman and Lawrence (1993)]. Thus for example, Bhagwati and Kusters (1994) conclude: "The contention that the factor prices changed as they did in the 1980s because of trade – when in fact goods prices changed in a way opposite to what would happen if trade were the explanatory factor – is illogical and hence unpersuasive."

The bargaining approach we develop here, which does not depend on a particular movement of relative goods' prices, suggests otherwise however. In our model, increasing product market competition induced by trade can lead to wage reduction irrespective of whether prices of the good produced by the industry in question are falling more or less than those

which is however not dependent on union status, suggesting that the sharing of rents is not dependent on unionization as such.

of other goods. Further, unlike in the Stolper-Samuelson mechanism it is not *necessary* for wages for a type of labor to fall relatively more than the prices of the goods produced intensively with that type of labor, in order for wages to fall at all. Thus the observed absence of this phenomenon [see e.g. Deardorff and Hakura (1994)] is not a sufficient test of whether trade is influencing real wages. The second focus, on the relation between wages and measures of the extent of trade, has also led to ambiguous and controversial conclusions. The bargaining approach also suggests an inadequacy in the methodology of these studies however. In the model presented below, it is the *threat* of trade rather than trade itself which produces the observed outcomes. As a result it is unnecessary to observe trade taking place (let alone to increase) in order for a reduction in trade barriers to have an effect on wages. For both of these reasons, current approaches to examining the impact of trade on wages are inadequate.

Is there evidence that the impact of trade on wages operates through the channel of influencing rent sharing? Abowd and Lemieux (1991) econometrically analyze a large number of collective bargaining agreements alongside industry import and export data in the United States and Canada and find that "import competition has large employment effects in unionized establishments - larger than the effects one would predict by mechanically assuming that all imports replace domestic production dollar for dollar... For the United States, increased import competition is associated with relatively large decreases in real wage rates, but increased export activity is associated with real wage changes of modest magnitude". This is exactly the result that might be expected if owners of capital gain substantially in their intra-firm bargaining position as a result of the labor discipline effect induced by increased

competition in existing markets.³

A necessary condition for the bargaining channel as described above to be an influential factor in wage stagnation is increasing elasticities of product and labor demand at the firm level. The notion that "international trade increases competition" was hailed as the "oldest idea" in the realm of trade and imperfect competition by Helpman and Krugman in their book *Trade Policy and Market Structure* (1989). The idea that import competition may introduce market discipline was empirically tested by Levinsohn (1993), who found import penetration to have reduced markups in Turkish industries as predicted by the theory. In turn, some evidence that labor demand elasticities for production workers have risen in recent years in the United States is provided by Slaughter (2001) and Richardson and Khripounova (1996). The former argues that between 1961 and 1991 demand for US production labor became more elastic in aggregate and for a majority of industries (considered at the two-digit level). The latter similarly contends that there was a rise in the elasticity of demand for US production workers between 1979 and 1991.⁴ These results are suggestive, but do not necessarily mean that labor demand elasticities have been increasing at the firm level.

Some recent careful empirical research on the consequences of trade liberalization in less developed countries have found substantial wage reduction effects, with wages falling most in sectors where rents had been highest prior to trade liberalization. Revenga (1997) finds for the case of Mexico that "the effects of trade liberalization on firm wages appear to have been quite substantial: for an average tariff reduction of 20 percentage points, the implied

³This view is contrary to that presented by Lawrence and Lawrence (1985). Their so-called "end-game" interpretation describes the possibility of unions in a declining industry, who see little future for it, seeking to maximize their extraction of surplus in the short run, and therefore raising wages.

⁴However, trade related measures appear to incompletely explain this rise.

wage response was on the order of 5%-6%." As well, reforms led to limited reductions in employment, even in previously protected sectors. The findings on wage loss due to trade are confirmed in Feliciano (2001), and similar results are found for Morocco by Currie and Harrison (1997).

Harrison and Hanson (1999) notes that wage inequality in Mexico between skilled and unskilled workers has been increasing, "which is puzzling in a Heckscher-Ohlin context if Mexico has a comparative advantage in producing low skill-intensive goods." They provide evidence suggesting that tariffs fell most in sectors having a higher share of unskilled workers. As a result, their finding is consistent with the possibility that the observed wage reductions resulted from product market competition induced worsening of workers' bargaining position. Indeed, Hanson and Harrison (1995) write of Mexico that "the rising wage gap is associated with changes internal to industries and even internal to plants that cannot be explained by Stolper-Samuelson effects." Findings of falling wages and rising inequality are also reported by Galiani and Sanguinetti (2003) in the case of Argentina. Finally, a similar theme is present in Harrison (2002), where she finds that globalization has reduced labor's share of national income in a cross-country panel with developed and developing countries. The presence of significant intra-firm bargaining effects combined with economic or political factors which enabled skilled workers better to influence tariff rates and other trade policies than unskilled workers would help to explain the observed phenomenon. Rodriguez and Ortega (2006) find that increased trade openness is associated with lower capital shares in national income to a degree that is increasing in a country's unionization rates, and that this finding is "consistent with a model of wage bargaining".

The existing theoretical literature on the effect of product market competition on bargain-

ing between workers and firms, particularly in the context of international trade, is small. A notable contribution is that of Huizinga (1993) who considers a case in which two individual markets consisting of single union-firm bargaining units (i.e. a monopolistic producer facing a single national union) are merged into a unified market with two bargaining units. There is a single good, linear demand and production, Cournot competition among firms, Stackelberg wage setting by unions, and the assumption that unions maximize union rents (given by the union wage bill minus the (constant per-worker) total opportunity cost of union labor). In this simple environment, a wage setting game between unions in the integrated market arises, in which wages fall but, due to the output increasing effect of competition among a larger number of firms, employment rises to such an extent that union "utility" rises. Prices fall due to increased competition, and firms' profits rise, due to the fall in union wages. The paper emphasizes that both workers and firms benefit in all cases, in this environment.

The model we present below, by generalizing the environment to one in which workers' objectives, the extent of market integration, the number of firms, and the degree of worker organization in different regions undergoing integration, are allowed to vary, develops results which are often divergent from these. Indeed, it is shown that Huizinga's result is a knife-edge result which for a class of models is *only* possible in the specific case he analyses. Importantly, in the model below, although profits can rise or fall, the degree of achievement of workers' objectives almost always falls. Munch and Skaksen (2002) extend the model of Huizinga to accommodate continuous variation in the tariff rate and fixed costs of exporting. Mezzetti and Dinopoulos (1991) also find that trade liberalization reduces bargained wages in a Cournot duopoly model of a domestic unionized firm and a foreign (non-unionized) firm.

Other papers addressing loosely related issues are those of Driffill and van der Ploeg

(1995) and of Rama and Tabellini (1998). Driffil and van der Ploeg (1995) examine how the removal of trade barriers reduced monopoly power in labor markets. They find that reduction in trade barriers causes unions to accept lower wages. As we do, they examine the process of wage setting under imperfect competition. However, they specialize to the case of national or international level monopoly unions and assume monopolistic competition and increasing returns to scale. They do not examine the effect of integration on profits or the logic of the wage-setting game between decentralized unions, as we do below. Rama and Tabellini (1998) examine the political economy of the setting of minimum wages under alternative tariff regimes, finding that high tariff regimes generate higher minimum wages. Naylor (1998) finds a contrary result, that integration of markets (in the sense of a reduction in tariff rates) tends to lead to an increase in union wage demands, which leads to an increase in union "utility" and a decrease in profits. This result is driven by the special assumption that firms engage in reciprocal dumping [see Brander and Krugman (1983)] in which producers in each market engage in price discriminating sales to consumers in the other market as a result of the perceived difference in domestic and foreign elasticity of demand induced by the existence of a tariff. A tariff reduction reduces the incentive to engage in such foreign sales and thus paradoxically reduces the elasticity of derived labor demand, in contrast to the normal expectation that the tariff reduction would do the opposite. The model presented below will not rely on this specialized assumption.

Whereas the existing literature has noted that trade liberalization can lead to wage reductions it has not explored in a systematic framework the manner in which trade-liberalization affects the wage-setting game. In this paper, we identify the logic according to which changes in product market competition affect the strategic calculus of various parties and

thereby the equilibrium of the wage-setting game. This allows us to decompose the wage discipline induced by trade liberalization into component parts and thereby to more sharply characterize the "race to the bottom" that can be associated with trade liberalization.

2. The Model

We begin with a benchmark model where workers in some proportion of the firms in each region are organized. We assume that whether a firm's workers are organized has already been determined, and that decentralized bargaining occurs between workers and firms' owners at the establishment level. Finally, the model we consider here is a partial equilibrium one, in that we consider effects on nominal wages and profits. In subsequent sections, we will consider the cases of multi-establishment and multi-national unions, and will also examine the effect of integration on real wages and profits.

2.1. *Workers Organized Independently at Competing firms*

2.1.1. *The Framework of the Benchmark model:*

The Regional Market:

In order to focus on the logic of intra-firm bargaining, and the effects of inter-firm and inter-worker competition, we assume a simplified framework. Specifically, we assume a market for a single homogeneous good, and a single factor of production (labor) produced by a constant returns to scale technology $q(n) = n$, where $q(n)$ is the quantity produced by the firm and n is the level of employment by the firm. We assume that initial market demand is characterized by a linear demand function $p = a - bQ$. As we discuss in a later section,

a representative consumer with quadratic quasi-linear preferences generates such a demand function, although it can be rationalized by other assumptions as well. The linear demand assumption plays a simplifying role in the analysis but is not essential to derive our results.⁵ We assume also that there are f firms, some of whom are organized and engage in enterprise level collective bargaining.

The Integrated Market:

We will consider the experiment of fully integrating an arbitrary number, k , of identical regions (except possibly for the level of unionization), each having an identical number of firms, f , with identical characteristics, and each furnished with its own identical demand function. We will refer to k as the "scale of integration." It has the dual interpretation of the number of identical regions being integrated and the size of the region with which integration is occurring (i.e., $(k - 1)$ times the size of the "home" region). As integration proceeds, the number of firms as well as the scale of demand increase proportionately. In an integrated area with k regions, the market demand function is $p = a - \frac{b}{k}Q$.

We note that at any given level of market integration, there are $m = \gamma f + \theta f(k - 1)$ firms with workplace organization, where γ is the proportion of firms which have organized workers at "home" and θ is the proportion which do so "abroad" (i.e. in the region(s) with which integration is occurring).

Workers' and firm's objectives:

The objectives pursued by each set of workers (or a "worker-collective") are assumed

⁵The more general case of uniformly convex or concave demand curves is considered by Reddy (2000). It is argued there that liberalization induced reductions in bargained wages and in workers' share of available rents can arise in such a context if the the derived labor demand curves of firms are "not too convex to the origin in the region of the wage adjustment".

to be described by the objective function $U = n^\beta(w - w_0)$, where $\beta \in [0, \infty)$ and w_0 is an outside option defined by a competitive labor market or return from home production. This objective function encompasses the paradigmatic case of "rent maximization" corresponding to $\beta = 1$, that has been of considerable interest in the labor economics literature, as well as accommodating arbitrary alternative weights on employment.⁶ Firms are assumed to maximize profits, which are given here by $\pi = (p - w)n$, where p is the price level. Neither consider the impact of their decisions on the cost of consumption.

Stages of the game:

We assume that there are two stages in the game determining the outcomes (wages, employment, and profits). In the first stage, bargaining takes place between the firm and the workers over the level of the wage which will prevail in the second stage. Each worker-collective/firm pair is assumed to negotiate according to the generalized Nash bargaining model [see e.g. Svejnar (1986)]. The worker-collective is assumed to have an arbitrary degree of bargaining power $\lambda \in [0, 1]$, with the firm having bargaining power $(1 - \lambda)$. The firm's outcome in the event of the breakdown of negotiations is assumed to be zero profits. i.e. in the event of a failure to come to agreement with its own workers the firm cannot make

⁶The assumption of rent maximizing worker-collective behavior has been widely justified on the grounds that it has plausible "micro-foundations." Specifically, risk-neutral workers can under specific assumptions be expected to form rent-maximizing worker-collectives [See for example Oswald (1982)]. However, some empirical evidence suggests that unions pursue employment objectives to a larger extent than suggested by the "rent maximization" model [See MaCurdy and Pencavel (1986), McDonald and Solow (1981) etc.]. As well alternative theories which assign a greater decision making role to older and more senior employee (who for example would be likely to prevail in a median voter model of worker-collective behavior) would suggest that worker-collectives pursue wage objectives to a larger extent than suggested by the "rent maximization" model. The characterization of worker-collective objectives here is meant to accommodate all of these possibilities. It does however have the feature of suggesting that the interests of the unemployed are at least partially taken account of in worker-collective decision making. This view, consonant with McDonald and Solow (1981) is disputed by, among others, Layard, Nickell and Jackman (1991). An alternative rationalization is that "union bosses" have employment as an objective as it is a component of total rent, or alternatively of derived social or political power.

recourse to the competitive labor market. In the event of a breakdown of negotiations, organized workers can find employment at the competitive wage rate, w_0 , or equivalently earn that return from home production. It is important to note that although both workers' and firms' relative bargaining power and outside options are both constant, this is not true of their *bargaining position*. The latter, which is a broader concept, should be understood as the totality of the advantage that can be realized by a particular party to the bargaining process, i.e., the share of output obtained by each party. In the first stage, this bargaining occurs simultaneously in each organized firm, where workers and firms at firm i take as given the outcomes of the wage negotiations in all other firms $j \neq i$.

In period two, each firm chooses an employment (and hence output) level simultaneously, where competition among firms is assumed to take a Cournot-Nash form. Each firm takes its own and others' wage rates as given and competes in quantities so as maximize its profits. These assumptions concerning the nature of inter-firm competition simplify the analysis but are not essential to arrive at our conclusions.⁷

Formally, the equilibrium negotiated wage w_i in firm i in the first-stage bargaining process can be represented as the maximand of the following optimization process:

$$\max_{w_i} N_i = [n_i^\beta (w_i - w_0)]^\lambda \cdot [(p_i - w_i)n_i]^{(1-\lambda)} \quad (1)$$

subject to: (1) $n_i = n(w_i | \mathbf{w}_{-i})$

(2) $p = p(n_i | n_{-i}(\mathbf{w}_{-i}))$

where $n(w_i | \mathbf{w}_{-i})$ is the firm's implicit labor demand curve in period two, taking as given

⁷A straightforward way to generalize these assumptions is to parametrize the degree of competition or collusion by using a conjectural variations model. The central result that we derive – in which decreases in bargained wages and in the share of rents accruing to workers (perhaps sufficient to cause profit increases) are a result of increased integration – can be derived in this more general case. Under Bertrand competition among firms, wages are generally set at the competitive level and no such consequences arise.

the vector of wages faced by other firms. Similarly, $p(n_i|n_{-i}(\mathbf{w}_{-i}))$ is the second period equilibrium price facing the firm, based on the firm's residual product demand. In period 1, then, the firm takes as given the wages (and hence the optimal period two output) faced by each of its competitors. This includes the $(fk - m)$ unorganized competitors, who produce facing the competitive wage w_0 .

Both parties to this bargaining process take into account the effect which the wage they set will have on their ability to achieve their preferred outcomes in the second stage, through anticipating the outcome of the second stage Cournot game among firms associated with each wage level. In period 1, each worker-collective/firm pair perfectly forecasts other firms' period two output given the vector of wages they face. The wage which results from this bargaining process must also be the wage at which the resulting Cournot-Nash equilibrium among firms facing identical wages is such that unilateral deviation by a worker-collective/firm pair choosing an alternative wage could not lead to a higher level of composite (Nash-bargaining induced) objective N .

Our assumption is that employment is determined in the second stage solely by the firm, which may hire as few or as many workers as it wishes at the wage rate determined at the first stage. We refer to this as the "right to manage" assumption. This assumption ensures that the firm is on its labor demand curve in period two, although the specific point along the curve that it takes up will be dependent on the prior bargaining process between employers and workers. This assumption is important to the subsequent analysis as it makes especially stark the effect of increased competition on the shape of the objective possibility frontier faced by the parties, and generates a clear interpretation of this change in terms of the

increased employment cost of wage increases. One may worry that the ex-ante inefficiency of the bargaining model may be responsible for some of our findings. However, that feature of the model is not necessary to arrive at the results that we present.⁸

Furthermore, there are both empirical and theoretical grounds reasons to adopt this assumption. There is widespread evidence that the characterization of collective bargaining as focused on wages while proffering a subsequent residual right to determine the employment level to the employer is often realistic.⁹

2.1.2. *Results of the Analysis*

The wage-setting game:

The symmetric equilibrium wage w^* can be solved for in steps, proceeding backwards from the second to the first stage of the game. In period two, in the Cournot game between firms, given its own wage w_i and other firms' output n_{-i} , each firm solves

⁸The central conclusion of our analysis - that integration results in decreases in bargained wages as a result of a diminished share of available rents for workers, possibly sufficient to raise profits - can be derived in a model in which intra-firm bargaining is efficient (because it is over wages and employment jointly). Reddy (2000) demonstrates that our results can be arrived at when the outside options of the parties are endogenous by considering a model in which non-unionized workers threaten to unionize if they are not provided with at least as high an increment to total compensation as they would receive if they were unionized and engaged in the bargaining game described in this paper. The meaning of "unionization" here is simply the imposition upon the firm of the non-cooperative game in which bargaining is inefficient. Product market competition can, by shifting the labor demand curve that would be made recourse to *in the event* that the threat was realized, lead to changes in the distribution of surplus. These changes arise even though the threat is never realized in equilibrium. This form of efficient bargaining is of the same general form as the "Separate Spheres" bargaining model described by Lundberg and Pollak (1993). Chapter two of Reddy (2000) identifies further cases in which changes in bargained shares can result from changes in product market competition even when outside options are not endogenous. See also Mezzetti and Dinopoulos (1991).

⁹Layard, Nickell, and Jackman (1991) state that "employment is almost never bargained over as such." Moreover they report that US contracts typically include a "management rights" clause, asserting "that the company 'will determine the extent of any required force adjustments'". Further, strike in pursuit of an employment objective is in the US typically illegal, in the sense that doing so risks loss of protection of collective bargaining under the National Labor Relations Board. They also report the results of Oswald (1987) to the effect that only 5 out of 120 British and American unions surveyed reported that they 'normally negotiate over the number of jobs as well as over wages and conditions'. Hall and Lilien (1979) also find that firms often set employment unilaterally.

$$\max_{n_i} (p(n_i | n_{-i}) - w_i) n_i \quad (2)$$

for which the first order condition is

$$n_i = \frac{k}{b} (p - w_i). \quad (3)$$

However, given the fk firms in the market at any stage of integration, we have the equilibrium condition that

$$p = a - \left(\frac{b}{k}\right) \sum_{j=1}^{fk} n_j = a - \left(\frac{b}{k}\right) \sum_{j=1}^{fk} \frac{k}{b} (p - w_j) \quad (4)$$

which implies that, for any given vector of wages in firms,

$$p = \frac{a}{(1+fk)} + \frac{1}{1+fk} \sum_{j=1}^{fk} w_j \quad (5)$$

and in turn that

$$\begin{aligned} n_i(w_i, \mathbf{w}_{-i}) &= \frac{k}{b} \left(\frac{a + \sum_{j=1}^{fk} w_j}{(1+fk)} - w_i \right) \\ &= \frac{k}{b} \left(\frac{a}{(1+fk)} + \frac{\sum_{j \neq i} w_j}{(1+fk)} - \frac{fk}{(1+fk)} w_i \right) \end{aligned} \quad (6)$$

The output of a firm in period two depends on wage it faces, as well as the wages faced by its competitors. The remark below establishes that, *ceteris paribus*, the own-wage elasticity of employment increases in magnitude with the scale of integration, confirming the presumption of Rodrik (1997).

Proposition 1 *For a given average wage faced by its competitors, \tilde{w}_{-i} , labor demand at firm i becomes more elastic with respect to its own wage with scale of integration, k .*

Proof. First, we define the average wage of competitors

$$\tilde{w}_{-i} = \frac{\sum_{j \neq i} w_j}{(fk-1)}.$$

Substituting \tilde{w}_{-i} into expression (6) produces

$$n_i(w_i, \mathbf{w}_{-i}) = \frac{k}{b} \left(\frac{a}{(1+fk)} + \frac{(fk-1)\tilde{w}_{-i}}{(1+fk)} - \frac{fk}{(1+fk)} w_i \right).$$

Own wage elasticity of labor demand is defined as

$$\eta = \frac{\partial n_i(w_i, \tilde{w}_{-i})}{\partial w_i} \frac{w_i}{n_i},$$

which in turn is equal to

$$\begin{aligned} & \frac{-fk w_i}{(a+(1-fk)w_i+(fk-1)\tilde{w}_{-i})} \\ &= \frac{-fk w_i}{(\tilde{w}_{-i}-w_i)+\left(\frac{(a-\tilde{w}_{-i}+w_i)}{fk}\right)}. \end{aligned}$$

Differentiating η with respect to k produces

$$\frac{d\eta}{dk} = \frac{-f^2 k w_i (a - \tilde{w}_{-i} + w_i)}{\left((\tilde{w}_{-i} - w_i) + \left(\frac{(a - \tilde{w}_{-i} + w_i)}{fk}\right)\right)^2 (fk)^2}.$$

The denominator is positive, and the non-negativity condition on firm profits requires that $(a - \tilde{w}_{-i}) \geq 0$, implying that the numerator is negative, and that $\frac{d\eta}{dk} < 0$.

In other words, demand becomes more elastic as k rises. ■

We now consider the first stage wage setting decision, where firms and workers bargain over the wage subject to the output function n_i , taking as given the vector of wages at other firms \mathbf{w}_{-i} . Substituting (6) into (1) and collecting terms produces the following reduced form optimization problem:

$$\begin{aligned} & \max_{w_i} N_i \\ &= \left(\frac{k}{b}\right)^{(\beta\lambda - \lambda + 1)} \left[\left(\frac{a}{1+fk} + \frac{\sum_{j \neq i} w_j}{1+fk} - \frac{fk}{1+fk} w_i \right) \right]^{(2-2\lambda + \beta\lambda)} [w_i - w_0]^\lambda \quad (7) \end{aligned}$$

Taking the first order condition and solving for w_i produces the following:

$$w_i = \left[\frac{a\lambda}{(\phi + \lambda)fk} + \frac{\phi}{(\phi + \lambda)} w_0 \right] + \frac{\lambda \sum_{j \neq i} w_j}{fk(\phi + \lambda)} \quad (8)$$

where $\phi = (2 - 2\lambda + \lambda\beta)$ is the total weight on employment.

Expression (8) is the reaction function of each worker–collective/firm pair, mapping the vector of wages \mathbf{w}_{-i} onto its own negotiated wage w_i . Before solving for the Nash equilibrium of this wage setting game, we will characterize the qualitative features of this reaction

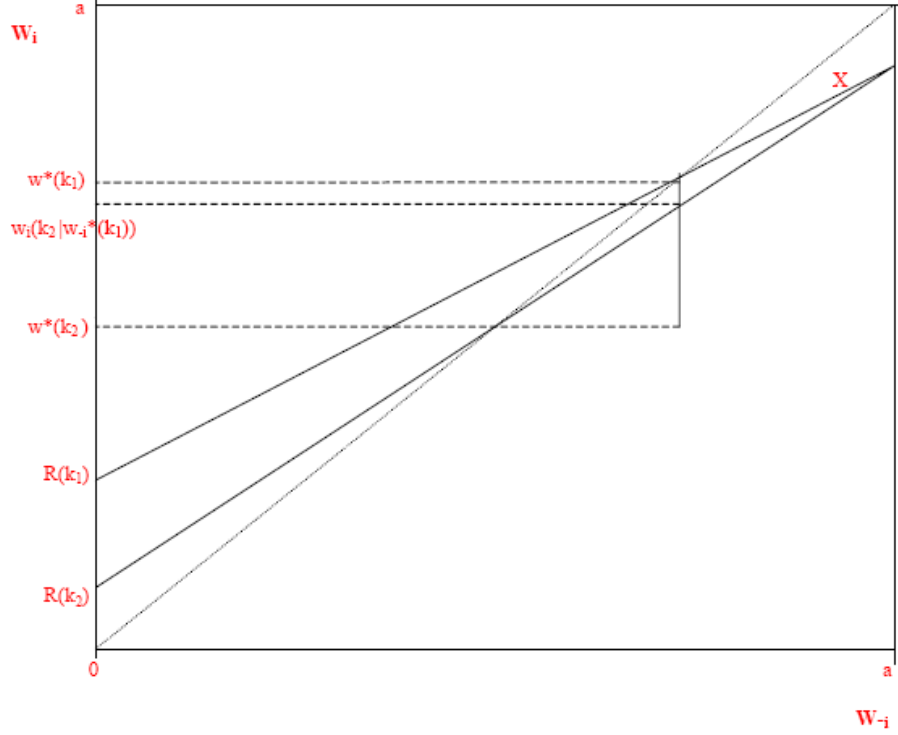

Decomposition:

Intra-firm bargaining effect = $w_i(k_2 | w_{-i}^*(k_1)) - w^*(k_1)$

Strategic Complementarity effect = $w^*(k_2) - w_i(k_2 | w_{-i}^*(k_1))$

Figure 1: Reaction Function of the Wage-Setting Game

function, and how it is affected by the key parameters. Defining the symmetric wage among organized competing firms as \hat{w}_{-i} , wage of w_0 at unorganized firms, and workplace organization at $m - 1$ firms, we can rewrite (8) as:

$$\begin{aligned}
 w_i &= \left[\frac{a\lambda}{fk(\phi+\lambda)} + \left(1 - \frac{\lambda m}{(\phi+\lambda)fk} \right) w_0 \right] + \frac{\lambda(m-1)}{fk(\phi+\lambda)} \hat{w}_{-i} \\
 &= \left[\frac{a\lambda}{fk(\phi+\lambda)} + \left(\frac{1}{\lambda} + \frac{(\theta-\gamma)}{(\phi+\lambda)k} - \frac{\theta}{(\phi+\lambda)} \right) w_0 \right] + \left[\frac{\gamma}{(\phi+\lambda)k} + \frac{\theta(k-1)}{k(\phi+\lambda)} - \frac{1}{fk(\phi+\lambda)} \right] \hat{w}_{-i} \\
 &= \left[\frac{a\lambda}{fk(2-\lambda+\lambda\beta)} + \left(\frac{1}{\lambda} + \frac{(\theta-\gamma)}{(2-\lambda+\lambda\beta)k} - \frac{\theta}{(2-\lambda+\lambda\beta)} \right) w_0 \right] \quad \{\text{INTERCEPT=I}\} \\
 &+ \left[\frac{\gamma}{(2-\lambda+\lambda\beta)k} + \frac{\theta(k-1)}{k(2-\lambda+\lambda\beta)} - \frac{1}{fk(2-\lambda+\lambda\beta)} \right] \hat{w}_{-i} \quad \{\text{SLOPE=S}\} \quad (9)
 \end{aligned}$$

As (9) shows, the slope term of the reaction function is strictly positive if $m > 1$. As long

as there are worker-collectives in some competing enterprises, there is strategic complementarity in the first period's wage setting game between worker-collective/firm pairs. When all other things are equal, a higher wage negotiated by a worker-collective in a rival firm allows worker-collectives in a particular enterprise to negotiate a better wage. Figure 1 graphically presents the reaction function for the negotiated wage. We now note some key properties of the slope and the intercept terms. These properties follow immediately from differentiating the terms in expression (9). The proofs are omitted as they are straightforward:

Remark 1 *If there is at least some worker organization in competing enterprises (i.e., $m > 1$) higher levels of workers' bargaining power and a greater scale of integration make workers' bargained wage at an enterprise more sensitive to wages negotiated at competing enterprises. In contrast, increased weight placed on employment by the worker-collective reduced this sensitivity. $\frac{dS}{d\lambda} > 0$, $\frac{dS}{d\beta} < 0$, $\frac{dS}{dk} > 0$*

Remark 2 *If there is at least some worker organization in competing enterprises (i.e., $m > 1$) higher levels of workers' bargaining power increase the bargained wage even in isolation from any strategic interaction, while increased scale of integration and increased weight placed on employment by the worker-collective reduces it. $\frac{dI}{d\lambda} > 0$, $\frac{dI}{d\beta} < 0$, $\frac{dI}{dk} < 0$*

The equilibrium bargained wage and workers' share of rent:

Finally, by imposing symmetry in wages across (identical) organized establishments, we can derive the equilibrium wage:

$$w^* = w_0 + \frac{(a-w_0)}{(fk\frac{\phi}{\lambda} + fk + (\theta-\gamma)f - \theta fk + 1)} = w_0 + \sigma(a - w_0) \quad (10)$$

This expression has a natural interpretation. As noted earlier, $w_0 \leq a$ is the non-negativity (or no-shut-down) condition on firm's profits. As well, a is the positive intercept

of the demand curve. As such, it is the maximum price that a consumer would be willing to pay for a unit (namely the first) of the good. The maximum wage that could possibly be supported without shutting down all firms is this amount. Therefore, a is a measure of the level of wages permitted by the "extent of the market", and $(a - w_0)$ is a measure of the maximum rent which it is feasible for a worker to capture. We can interpret ϕ as the joint (workers' and firm's) weight on employment in the worker-collective/firm bargaining problem, which is apparent from the inspection of (7).

Whereas a higher wage is desired by workers alone, a level of employment higher than zero is desired by both workers and the firm, both because it is (for the former) valued directly and (for the latter) at any given wage it is profit increasing.

Thus the numerator of the second term contains a measure of the surplus available to be extracted by firms in the form of wages and the denominator contains a measure of the desire at each site (inversely related to ϕ , the joint Nash bargaining weight on employment as against wages), and ability (directly proportional to workers' bargaining power λ and inversely proportional to the extent of inter-firm or inter-worker-collective competition as described by the total number of firms fk) to achieve high wages. In other words, *ceteris paribus*, equilibrium organized workers' wages are higher when workers' bargaining power (as determined for example by institutional conditions) is higher, when the competitive wage (or outside option) is higher, and when consumers' willingness to pay for the good is higher. All of these relationships are as might be expected.

Proposition 2 *Workers' share of the surplus, σ , and hence the equilibrium bargained wage, w^* ,*

fall with the level of integration k , i.e., $\frac{dw^}{dk} < 0$*

Proof. Differentiating (10) with respect to k , we obtain:

$\frac{dw^*}{dk} = - \left(\frac{(a-w_0)f}{[(fk\frac{\phi}{\lambda} + fk + (\theta-\gamma)f - \theta fk + 1)]^2} \right) (\frac{\phi}{\lambda} + 1 - \theta)$, which is negative as long as $a > w_0$, and is always true in the economically relevant region (i.e. when production is profitable). ■

Further differentiating $\frac{dw^*}{dk}$ shows that $\frac{d^2w^*}{dw_0dk} > 0$, $\frac{d^2w^*}{dadk} < 0$, and $\frac{d^2w^*}{dk^2} > 0$.

The rate at which wages decline diminishes as integration proceeds, and is lower when the competitive wage is higher although it is higher when consumer maximum willingness to pay for the good is higher.

Remarks 1 and 2 along with Proposition 2 lay out the logic behind changes in equilibrium wage. Higher bargaining power within the firm raises equilibrium wages by both increasing the response to other firms' wages and by increasing the wage that would be set even in the absence of strategic interaction with other workers. A higher workers' weight on employment in contrast, lowers equilibrium wages for *both* of these reasons. A higher competitive wage and a higher consumer willingness to pay for the good (a) raise equilibrium wages through their effect on the wages which would be set at firms in isolation, but not through any effect on the reaction with other firms.

Overall, the fall in wages through strategic interaction (i.e., S) acts to multiply the scale of the wage decline from an increase in k , and the strategic complementarity between worker-collectives works to ensure a "race to the bottom." A possible decomposition of the relative role of the firm-level bargaining effect (decline in intercept) and the increase in the strategic complementarity between workers at different production sites, in bringing about a decline in the equilibrium wage is outlined in Figure 1. For the special case $w_{-i} = w_0$ (i.e. an isolated organized worker-collective) it is possible to show that $\frac{dw_i(w_{-i})}{dk} < 0$. Thus, the

negotiated wage falls with integration even at a firm with an isolated group of organized workers showing that the strategic complementarity between workers acts to multiply the wage decline but not to cause it. As well, in this case, $\frac{d}{d\lambda} \frac{dw_i(w_{-i})}{dk} > 0$ and $\frac{d}{d\beta} \frac{dw_i(w_{-i})}{dk} < 0$. Thus, greater bargaining power unambiguously reduces the extent of the wage fall due to integration and greater weight on employment unambiguously increases it.

By differentiating (10) with respect to the relevant parameters, we establish further results: $\frac{dw^*}{d\gamma} > 0, \frac{dw^*}{d\theta} > 0$ (11)

In other words:

Remark 3 *Post-integration wages at home are higher when more firms initially possess organized workers "at home" and they are also higher when more firms have organized workers in the region(s) being integrated with "abroad".*

How does the level of organization at home influence the effects of integration? It can be shown that:

$$\begin{aligned} \frac{d^2w^*}{d\gamma dk} > 0 & \quad \text{if} \quad \theta > \gamma \quad \text{and} & (12) \\ < 0 & \quad \text{if} \quad \theta < \gamma \end{aligned}$$

In short:

Remark 4 *Greater organization at home reduces the rate at which wages fall if foreign regions are more organized than at home. However, greater organization of workers at home increases the rate at which wages fall if the level of foreign organization is less than at home.*

Moreover we can deduce from the expression for $\frac{dw^*}{dk}$ that $\frac{d^2w^*}{d\theta dk} > 0$. (13)

Remark 5 *When two regions integrate, greater organization "abroad" reduces the rate at which wages fall.*

How does integration affect the extent to which workers attain their overall objectives, inclusive of employment as well as wages? We derive the equilibrium realization of the workers' objective may be calculated by substituting the equilibrium wage (10) and employment per firm (derived from (6)) into the workers' objective function. To simplify the algebra, here, we only consider the case of organization in all enterprises $m = fk$, which allows us to derive:

$$U = \left(\frac{(a-w_0)}{(fk\frac{\phi}{\lambda} + fk + (\theta-\gamma)f - \theta fk + 1)} \right)^{1+\beta} \left(\frac{k^2 f \phi}{b\lambda(1+fk)} \right)^\beta \quad (14)$$

By differentiating this with respect to k , and simplifying, we may derive that:

$$\frac{dU}{dk} > 0 \text{ iff} \\ f^2 k^2 (-2 + 2\lambda - \lambda\beta) + fk(2\beta - 2\lambda\beta + \lambda\beta^2 - 2 + 2\lambda) + 2\beta\lambda > 0 \quad (15)$$

The first coefficient is negative, the second may be positive or negative, and the last is positive. It follows that workers' objective fulfillment rises "early" in the integration process if it rises at all, and that it necessarily ultimately falls. It may be readily checked for example that in the case where workers have complete wage setting power, and pursue the rent maximization objective (i.e. $\lambda = 1, \beta = 1$) the *only* economically relevant case for which workers' objectives rise is the case in which two economies with one firm in each merge. thus the result identified by Huizinga (1993) of rising "union utility" in the presence of market integration is *not* robust.

Equilibrium profits:

What about profits? The profit of a firm with organized workers is given by:

$$\pi = \frac{k}{b(1+fk)^2} \left(\frac{(a-w_0)\frac{fk\phi}{\lambda}}{\frac{fk\phi}{\lambda} + fk - m + 1} \right)^2 \quad (16)$$

Differentiating the profit expression (16) with respect to k , we find that $\frac{d\pi^*}{dk} > 0$ if and only if

$$\begin{aligned} & -7f^3k^3\theta + (5f^2 - 3f^2\theta - 5\gamma f^3 + 3f^3\theta)k^2 + \\ & (f^2\theta - 3\gamma f^2 + 3f\phi + f^2\theta + 3f + 3f\lambda + 2\theta f)k + 2 - \lambda + \lambda\beta > 0 \end{aligned} \quad (17)$$

Although it is difficult to fully characterize the conditions under which this expression is positive, we can conclude that:

Proposition 3 *Profits eventually fall with integration, k . Moreover, profits rise with k for sufficiently small values of k (although possibly for the economically irrelevant case of $k < 1$).*

There exist cases in which profits rise between $k = 1$ and $k = 2$.

Proof. The first statement follows from the fact that the cubic term of the derivative, with respect to k , is negative, and this dominates other terms for a large enough k . The second statement follows from the fact that the derivative at $k = 0$ is equal to $2 - \lambda + \lambda\beta > 0$. Finally, it can be shown that profits rise between $k = 1$ and $k = 2$ iff $f^2((2^{1/2} - 4) + (2^{1/2} - 4)\phi + 2\theta + (2 - 2^{1/2})\gamma) + f((2^{1/2} - 4) + (2^{1/2} - 2)\phi + \theta + (1 - 2^{1/2})\gamma) + (2^{1/2} - 1) > 0$. There exist admissible values of the parameters for which the statement is true. ■

We now specialize to the case of full organization for simplicity of exposition. In the full organization case (i.e. when $m = fk$) the profit of firms is given by:

$$\pi = \frac{k}{b(1+fk)^2} \left[(a - w_0) - \frac{(a-w_0)}{\frac{fk}{\lambda}\phi + 1} \right]^2 \quad (18)$$

This expression has a neat and natural interpretation, which becomes evident upon juxtaposition with the equilibrium wage expression.

The first term in the square brackets is as before a measure of the total surplus made

feasible by demand conditions (the "extent of the market"). The second term in the square brackets is as before a measure of the total desire and ability of workers to extract wage concessions from firms. The difference between these generates a measure of the extent of available market surplus potentially remaining to be extracted by a firm. This potential is however deflated by the initial term, which is a measure of product market competition and of the elasticity of overall industry demand.

Can profits rise with integration? It can be shown that for certain parameter ranges this is certain to happen. In particular,

$$\frac{d\pi}{dk} \geq 0 \quad \text{iff} \quad (kf)^2(-2 + 2\lambda - \lambda\beta) + kf(2 + \lambda\beta - \lambda) + 3\lambda \geq 0 \quad (19)$$

The first coefficient is negative and the other two are positive, unless $\lambda = 0$, which is the only circumstance in which case the last term is 0. Therefore profits always rise for k sufficiently small (possibly fractional). Also profits must eventually fall, and may do so throughout the economically relevant range (k and f integers). There is also only a single positive root to this expression.

Remark 6 *For the case of complete organization, profits follow an inverse-U shape in the level of integration, k . Also, for $\lambda = 1$, expression (19) implies that for any k^* , however large, there exists a β^* such that if $\beta < \beta^*$, $\frac{d\pi}{dk} > 0$ for all $k \leq k^*$. Therefore it is possible for profits to increase over an arbitrarily large range of integration. i.e. The wage discipline imposed by integration can compensate for the diminished rents arising due to integration even when the decrease in those rents is very large.*

Why do profits rise? It can be shown that, for the full organization case:

$$\frac{d\pi}{dk} = \left[\frac{1 - fk}{(1 + fk)^3} \left(\frac{(a-w)^2}{b} \right) - \frac{2k}{(1+fk)^2} \left(\frac{a-w}{b} \right) \frac{dw}{dk} \right] \quad (20)$$

Thus, the change in profits due to integration is influenced by both the *level* of the wage and the manner in which integration affects the wage. As noted above, when the level of the wage is higher, the potential total market post-production cost surplus per unit produced. The rate of change of profits is due to both the impact of the increased competition among firms to capture this potentially available surplus, reflected in the first term (recall that $\frac{1}{2} \left(\frac{(a-w)^2}{b} \right)$ is the area under the demand curve and above the marginal cost curve, represented by w) and the impact of the declining wage, reflected in the second term. The relative magnitude of the impact of increasing competition among firms and of the declining wage in determining the rate of change of profit is also influenced by the level of integration. The sole factor mitigating the adverse impact on profits of increased inter-firm competition is the wage decline.

2.2. *National and International Worker Coordination*

Are the results derived above dependent on the assumption that the level at which workers organize to achieve their objectives is that of the individual firm? In particular, do the results hold when workers are organized at a level beyond the enterprise, coordinating with other workers in a country or perhaps even with workers in other countries?

It is straightforward to extend the framework of the paper to consider such cases, by permitting a common wage to be set by a union¹⁰ in all of the enterprises in which it represents workers. We have considered a number of such cases. The first case that we have considered is that of trans-national unions. In this case, some proportion (possibly all)

¹⁰We refer to unions rather than worker collectives in this section and the next section as it is realistic to assume a degree of formality of worker organization when worker are organized at a level beyond the individual enterprise.

of workers at "home" belong to a common union though they work in different enterprises, and as market integration occurs workers in the newly integrated regions join this union in the same proportion as at "home". A second case that we considered is that in which some proportion (possibly all) of workers at "home" belong to a common union although they may work in different enterprises, but there is no unionization abroad and the union gains no new members at home or abroad when integration occurs. A third case we considered is that in which some proportion (possibly all) of workers in each country belong to a common union though they work in different enterprises, and a different such union represent workers in each country. When integration takes place the different unions enter into strategic interaction with each other.

We do not report the details of the analysis here although it is available on request and presented in Reddy (2000). We make the Stackelberg assumption of complete wage-setting power by unions. We find that in all three cases wages fall as a result of integration as long as the unions do not include all workers in the industry (in which case, with trans-national unions, they are constant). Wages are higher but also fall more as a result of integration when a larger proportion of workers belong to the union. Wages always fall more when liberalization takes place and unions are national (so that they do not coordinate with a counterpart abroad, if one exists) rather than trans-national. Profits do not rise in the first two cases but they *can* rise in the third (competition between national unions).

2.3. *Endogenous Unions*

Do liberalization induced increases in product market competition influence the desirability and feasibility of forming unions and maintaining them over time? How does the

ability of unions to realize their objectives vary with the extent of unionization in the economy? It can be shown that $dU/dm > 0$. In other words, the ability of unions to realize their objectives increases as the extent of unionization increases. Thus, both unions and unionized firms favor greater unionization.

For the case of rent-maximization, in which the union's objective can be measured straightforwardly in money terms, it can be shown that the ratio of equilibrium union rent to profit at any given level of integration is given by:

$$\frac{U}{\pi} = \frac{(1+fk)\lambda}{\phi fk} \quad (21)$$

This ratio is directly proportional to union bargaining power and inversely proportional to the joint weight placed on employment in the union-firm bargaining process. Further and most interestingly $\frac{d(U/\pi)}{dk} < 0$ and $\frac{d(U/\pi)}{df} < 0$. (22)

and $\lim_{k \rightarrow \infty} \frac{U}{\pi} = \frac{\lambda}{2-\lambda}$ from which it follows that:

Remark 7 *In the case of union rent maximization, the share of profits in total per-firm surplus, $\frac{\pi}{\pi+U}$, is rising as liberalization proceeds, and approaches an upper limit determined by the union's bargaining power, λ .*

Consider now a very simple model of union endogeneity. Assume that unions can demise as a result of a "contest of resources" between union organizers and firms, in which the potential costs of defending a union's existence would have to be paid out of existing union rents, and in which the costs of fighting union organization would have to be paid out of existing profits. Further suppose that the party that spends more resources (or resources that are greater to a sufficient extent) prevails. It follows from these assumptions that as long as profits are sufficiently larger than union rent unions will be pushed out of existence

and that as long as profits are sufficiently lower than union rent unions will maintain their existence. More formally, suppose that the union demises if $\frac{U}{\pi} < \Psi$. Note that for $k = 1$

we have $\frac{U}{\pi} = \frac{(1+f)\lambda}{f(2-\lambda)}$.

Assume that $\frac{U}{\pi}|_{k=1} < \Psi < \lim_{k \rightarrow \infty} \frac{U}{\pi}$. i.e. $\frac{(1+f)\lambda}{f(2-\lambda)} < \Psi < \frac{\lambda}{2-\lambda}$. It follows that:

Remark 8 *In the case of a "contest of resources" model with rent-maximizing unions, as liberalization proceeds, a point is reached at which all unions endogenously demise.*

It is straightforward to show that equilibrium union utility, which may also be interpreted as the benefit (B) to workers who unionize, is given by:

$$B = U = \left(\frac{(a-w_0)}{(fk^{\frac{\phi}{\lambda}} + fk^{-m+1})} \right)^{(1+\beta)} \left(\frac{k^2 f \phi}{b\lambda(1+fk)} \right)^{\beta} \quad (23)$$

from which it follows that B increases in m and falls with integration (k and f).

Integration, by shifting the union benefit or cost of organization functions can lead to union growth spurts or rapid declines. Consider a simple example, depicted in the accompanying Figure, which presents the mechanism described by Freeman (1997) in which the extent of union membership is assumed to be determined by whether the benefits of organizing workers at a particular site are greater than the costs of doing so. It is clear that if the benefits of union formation fall sufficiently, the equilibrium can shift from one of full unionization to one of partial or zero unionization. Integration can be responsible for a shift in the union formation benefit curve. A period of rapid decline in union membership can be the consequence. This helps to explain why such periods have some tendency to be correlated across countries [Freeman(1997)].

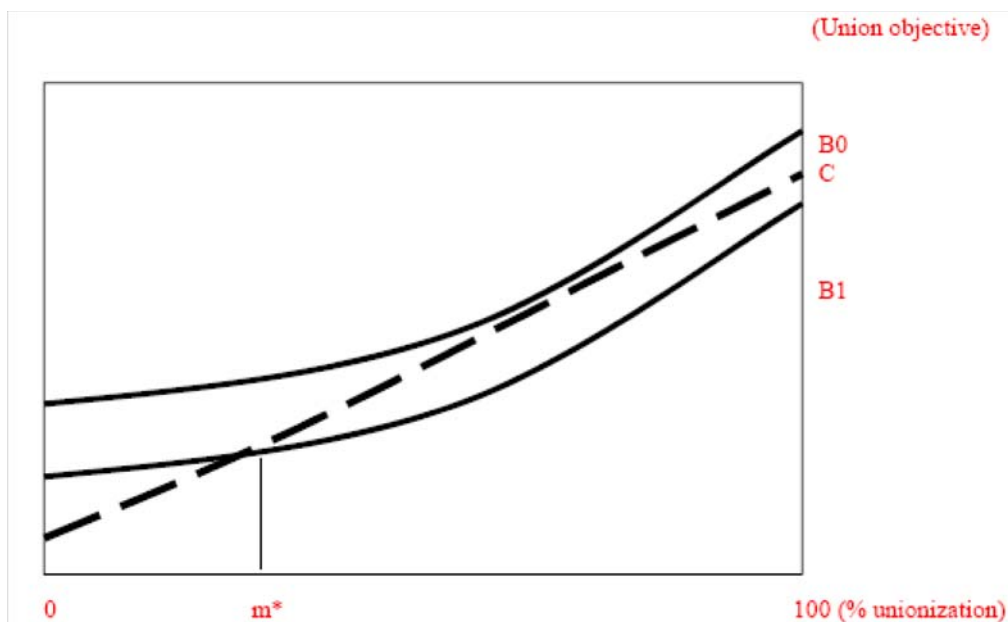

Figure 2: Rapid Decline of Unionization due to Liberalization

2.4. *General Equilibrium*

We have shown above that liberalization induced increases in inter-firm competition can lead to wage declines. However, these same increases in competition lead to price decreases. Workers taking advantage of the backstop technology or working in the competitive labour market at the fixed wage w_0 (if any) will be made better off by liberalization as a result. However, can workers in the industries with bargained wages likely to have lower *real* wages, as a result of liberalization? Can profits increase in *real* terms as a result of liberalization? We present below a simple model in which both of these outcomes can result.

We will construct a model in which there exists a continuum of oligopolistic industries. In each, the number of firms is possibly small. Thus firms' output decisions may have a noticeable effect on the price level in their own industries but do not have such an effect on the general price level of either workers' or employers' consumption baskets. However, the general

price level is affected by liberalization as it simultaneously influences price determination in each of the industries. We assume for simplicity that all industries have identical structures (demand curves and number of firms). Assumptions regarding demand (elaborated below) are made to ensure that the demand for each good is dependent only on its relative price vis-a-vis a numeraire good and is independent of prices of other goods. For simplicity, we also specialize to the case where all firms in the industries belonging to the continuum (jointly termed "the industrial sector") in all integrating regions are fully organized. We make the Stackelberg assumption that wage setting power rests entirely with workers (i.e. $\lambda = 1$) and assume the objective that workers pursue is rent maximization (i.e. $\beta = 1$). We assume that workers supply one unit of labor inelastically, and receive only wage income, either at level w_0 , if they work outside of the industrial sector, or w if they work within it.

In the specified circumstances, the partial equilibrium analysis undertaken earlier implies that in each industry the real wage (in relation to the good produced by that industry or the "own-good-real-wage") is:

$$\frac{w(k)}{p(k)} = \frac{a+fk w_0}{a+fk w(k)} = \left[\frac{a}{a+w_0fk} + \frac{fk}{(fk+1)} \right]^{-1} \quad (24)$$

from which it follows that $\frac{d(\frac{w}{p})}{dk} < 0$ iff $w_0 < \frac{a}{(fk)^2}$. (25)

The condition (24) for a falling own-good-real-wage is automatically satisfied at the onset of integration, if each industry is a monopoly, since $w_0 < a$ is a necessary condition for profits to be non-negative. More generally, this real-wage falls with integration if the competitive wage (or outside option) is sufficiently low, and if the number of firms in each industry is sufficiently small. Wages fall more rapidly than prices in these circumstances. Since the wage and price declines are identical in each industry, it also follows that when (25)

is satisfied, $\frac{d(\frac{w}{P})}{dk} < 0$, where P is any linear price index with fixed weights incorporating the goods produced by the continuum of oligopolistic industries and the goods produced outside the industrial sector (with fixed price). Further, since prices fall monotonically as integration proceeds, and since we have shown earlier that it is possible for profits to rise in the early stages of integration, as long as β and f are sufficiently low it is possible for real profits to rise with integration at the same time that real wages fall.

We now consider more comprehensive models in which we provide explicit foundations for the assumed demand curves and consider the impact of liberalization on utility. We will proceed in three steps. First, we will demonstrate the possibility of a decrease in industrial workers' utility due to liberalization in the case of a single industry economy. Second, we will demonstrate the possibility of a decrease in industrial workers' utility due to liberalization in the case where there is a finite number of industries. Finally, we will demonstrate the possibility of a decrease in industrial workers' utility due to liberalization in the case where there is an infinite number of industries.

First, we assume that there is only one industry, the consumption of the produce of which by a representative consumer is represented by x , and m is a numeraire good. The industrial good sells at price p . In order to rationalize our assumed linear demand curves, we assume that all workers and employers have quasi-linear utility functions of the form:

$$u(x, m) = z_1x - z_2x^2 + m \quad (26)$$

Workers earn only wage income and employers earn only profit income. Assume that all consumers have sufficient endowments of the numeraire good m such that there are no income effects. Then (x^*, m^*) is the consumer's optimal bundle of goods, where $x^* = x^*(p(k))$

and $m^* = m^*(w(k))$.

We may then describe an "indirect utility function" for industrial workers which describes the utility they experience given the bargained wage and prices prevailing at a particular level of integration, k , as follows:

$$v(k) = u(m^*(w(k)), x^*(p(k))) \quad (27)$$

We may then prove the following lemma concerning integration between two identical regions:

Lemma 1 *If $z_1 < z_2$ then $v(2) < v(1)$ always.*

Proof. $v(2) - v(1) = [z_1 x^*(p(2)) - z_2 (x^*(p(2)))^2 + m^*(w(2))] - [z_1 x^*(p(1)) - z_2 (x^*(p(1)))^2 + m^*(w(1))]$ (28)

Now, substituting in $m(k) = w(k) - p_1(k)x(p(k))$,

and the consumer's optimization condition $x^* = \frac{(z_1 - p)}{2z_2}$,

we can derive that $v(2) - v(1) < 0$ iff

$$\left(\frac{p(2)^2 - p(1)^2}{4z_2} \right) + \left(\frac{p(1) - p(2)}{2z_2} \right) z_1 + (w(2) - w(1)) < 0 \quad (29)$$

Since $p(2) - p(1) < 0$ and $w(2) - w(1) < 0$

therefore only the second term is positive.

A sufficient condition for the lemma to be true is therefore

$$\left(\frac{p(1) - p(2)}{2z_2} \right) z_1 < (w(1) - w(2)) \quad (30)$$

Under the specified parameters, from the partial equilibrium analysis,

$$w(k) = \frac{(w_0 f k + a)}{(f k + 1)} \text{ and } p(k) = \frac{a + f k w(k)}{(1 + f k)}.$$

Substituting these expressions in the above sufficient condition, it is possible to show that

$$v(2) - v(1) < 0 \text{ iff } \frac{z_1}{2z_2} < \tau(f) \text{ where } \tau(f) = \frac{(f+1)(2f+1)}{f(4f+3)}$$

It is easy to show that $\frac{d\tau}{df} < 0$. Moreover $\tau(1) = 6/7$ and $\lim_{f \rightarrow \infty} \tau(f) = 1/2$.

Therefore if $z_1 < z_2$ then, regardless of the number of firms, $v(2) - v(1) < 0$. ■

Thus, in the single industry case, industrial workers' utility falls with integration. If profits are also rising (for which independent sufficient conditions were earlier identified) then an employer's utility rises, since she benefits from both rising income and falling prices.

Now, let us broaden the scenario to include n distinct industries. Define

$$u_c(x_1, \dots, x_c, m) = \delta(z_1 x_1 - z_2 x_1^2) + \dots + \delta(z_1 x_c - z_2 x_c^2) + m \quad (31)$$

where each x_i represents a distinct commodity, which trades at price p_i . Note that this utility function implies identical linear demand functions for each commodity, 1 through c . The (identical) relative weight on each of these c distinct commodities in the utility function in relation to the numeraire good is given by δ . Let v_i refer to the indirect utility function (in the sense specified above) associated with u_i . We can now show that:

Proposition 4 *For any n , and for an arbitrary number of firms, there exist preferences such that $v_c(2) < v_c(1)$.*

Proof. $v_c(2) - v_c(1) =$

$$\delta(\sum_i ((z_1 x_i(p_2) - z_1 x_i(p_1) - z_2 x_i^2(p_2) + z_2 x_i^2(p_1)) + m(1) - m(2))$$

Consumer optimization implies that $x_i = \left(\frac{z_1 \delta - p_i}{2z_2 \delta}\right)$. As well, the worker's budget constraint implies that $m = w - \sum_i p_i x_i$. Substitution of these relations above and considerable simplification allows us to deduce that:

$$\begin{aligned} & v_c(2) - v_c(1) \\ &= \frac{c}{\delta} \left(\frac{p_1(2)^2 - p_1(1)^2}{4z_2} \right) + c \left(\frac{p_1(1) - p_1(2)}{2z_2} \right) z_1 + (w(2) - w(1)) < 0 \quad (32) \end{aligned}$$

It may be noted that this reduces to (28) when $c = \delta = 1$.

As in the single industry case, a sufficient condition for the result is for the second term to be smaller in magnitude than the third. It can be shown, analogously to the proof in the single industry case that this will be achieved if $\frac{cz_1}{2z_2} < \tau(f)$ where $\tau(f)$ is as defined above. Therefore, utility will always fall if z_1 is sufficiently small relative to z_2 . ■

Finally, let us address the case of a continuum of industries. We define:

$$u_\infty = [\int_0^1 (z_1 x(q) - z_2 x^2(q)) dq] + m \quad (33)$$

where each $x(q)$ represents a commodity along a continuous commodity indexation space $[0, 1]$. We now show that:

Proposition 5 $v_\infty(2) < v_\infty(1)$ *always*.

Proof. Let the weight on individual goods vary in exactly inverse proportion to their number, i.e. $\delta = 1/c$. Dividing (32) by c we get:

$$v_c(2) - v_c(1) = \frac{1}{\delta} \left(\frac{p_1(2)^2 - p_1(1)^2}{4z_2} \right) + \left(\frac{p_1(1) - p_1(2)}{2z_2} \right) z_1 + \frac{(w(2) - w(1))}{c} < 0$$

Note that as $c \rightarrow \infty$ the first term, which is negative, dominates the other two terms (the second term is finite and the third approaches zero). Therefore the inequality is always satisfied in this limit. hence, by the definition of an integral, $v_\infty(2) < v_\infty(1)$. ■

Remark 9 *In the case of a continuum of oligopolistic industries, even when the impact of integration-induced price decline is taken into account, an individual industrial worker's utility always falls. If the independent conditions for profits to rise are satisfied, then an individual employer's utility simultaneously also rises.*

A final category is that of non-industrial workers, employed at the wage w_0 . The utility of these workers necessarily rises, since their income is constant and the price level is falling.

The impact of integration on aggregate welfare is ambiguous because the impact that it has on levels of profit and on real wages of industrial workers is ambiguous. The impact of integration on the welfare of non-industrial workers is positive as it raises the level of employment in the industrial sector and increase the real wage of those workers who remain in the non-industrial sector. Of course, if sufficiently efficient tax and transfer instruments (e.g. lump-sum taxes and transfers) exist, then a pareto improvement can always be implemented due to the gains from trade which arise through the impact of increased competition on output.

3. Review and Conclusion

We have developed a model of the effects of product market competition on intra-firm bargaining over rents and thereby on the distribution of income between wages and profits. The model demonstrates that the increased inter-firm competition induced by trade liberalization is accompanied by decreases in the share of rents commanded by workers. The fundamental cause of this decrease in workers' share of rents is that heightened product market competition brings about increased wage discipline by increasing the employment costs of wage increases (and thus causing workers who value both of these objectives to moderate their wage demands). However, this first cause is accentuated by a race to the bottom arising from strategic complementarities in the wage-setting game between distinct groups of workers. Finally, decreases in organization by workers can occur due to the diminished resources available to them, further accentuating the adverse impact on workers' wages. Workers' wages can decrease in real as well as nominal terms. We have shown that these results are robust to the choice among various alternate specifications of the model. We have presented

a model of threat effects in the sense that the income distribution effects identified depend on the possibility of trade rather than its actual occurrence. Although our model assumed a degree of collective action on the part of workers, this assumption is not essential to develop results of the kind we have presented here. As Skillman (2000) notes, liberalization can lead to decreases in workers' bargaining position even in a setting of individualized bargaining, i.e. one in which workers' share of rents is determined by their individual threats to exit.

The bargaining approach developed here identifies income distribution consequences of trade which do not depend on relative factor abundance or other factors that are required in conventional models to explain the effect of trade liberalization on income distribution. Since there are gains from trade in this model the decreases in bargained wages that arise can in principle be overcome through appropriate ex-post transfers, if adequately efficient tax and transfer instruments are available. Insofar as such instruments are unavailable or are unused, the model provides some insight concerning the income distribution effects and political economy of trade policies.

An implication of the model is that the impact of trade policies on wages may be greater than that identified in present empirical studies which depend on relating changes in factor prices to changes in goods prices or to the implicit factor content of imported goods. The conclusion that skill-biased technical change or another "residual" is responsible for observed relative wage changes in developed countries may be questioned if the mechanism identified here is important. The model may also be useful in explaining the results of recent empirical studies which have shown that workers' wages in developing countries have not increased in the aftermath of trade liberalization as expected in conventional models.

The model presented here may also be useful in interpreting the political economy of

trade policies. A consequence of the model is that there is an inverse-U-shaped relation between the extent of trade liberalization and the level of profit, as a result of the conflicting effects of trade liberalization on total per-firm rents and on the share of rents captured by owners of firms. As a result, measures which bring about sufficient wage discipline to increase profits without dissipating rents entirely (such as regional trading arrangements) may be favored by owners of capital. Up to a point, firms may welcome the reduction of barriers to entry and firm owners may promote trade liberalization especially when workers initially earn substantial rents. In contrast to traditional models, organized workers may oppose trade liberalization and firm owners may welcome it in both developing countries and developed countries. Although it is too early to draw clear policy implications from the analysis above, it would appear that measures to enhance the bargaining power of workers and the degree of coordination among organized workers can play a potentially important role in moderating the wage decreases induced by trade liberalization.

The empirical magnitude of the effect of trade liberalization on wage discipline is a subject for further empirical investigation. Such investigation should consider explicitly the impact of liberalization on *profits* as well as on wages, and examine the relationship between measures of trade policy (as contrasted with measures of trade itself, such as trade volumes) and industry and firm level measures of the distribution of income.

4. References

- Abowd, J. M., and T. Lemieux, "The Effects of International Competition on Collective Bargaining Outcomes: A Comparison of the United States and Canada," *Immigration, Trade, and the Labor Market*, J.M. Abowd and R. Freeman, eds. (Chicago, IL: University of Chicago Press, 1991).
- Abowd, J. M., and T. Lemieux, "The Effects of Product Market Competition on Collective Bargaining Agreements: The Case of Foreign Competition in Canada," *Quarterly Journal of Economics*, CVIII (1993), 983-1014.
- Belzer, M. H., "Paying the Toll: Economic Deregulation of the Trucking Industry," Washington D.C.: Economic Policy Institute, 1998.
- Belzer, M. H., "Collective Bargaining After Deregulation: Do the Teamsters Still Count?" *Industrial and Labor Relations Review*, XLVIII (1995), 636-655.
- Bhagwati, J., and M. Koster, *Trade and Wages: Leveling Wages Down?*, Washington, D.C.: The American Enterprise Institute, 1994.
- Bhagwati, J., "Play it Again Sam: A New Look at Trade and Wages," Columbia University, mimeo, 1998.
- Blanchflower, David G., and Stephen Machin, "Product Market Competition, Wages and Productivity: International Evidence from Establishment-Level Data," *Annales d'Economie et de Statistique*, XLI-XLII (1996), 219-253.
- Blanchflower, David G., Andrew J. Oswald, and Peter Sanfey, "Wages, Profits and Rent-Sharing," *Quarterly Journal of Economics*, CXI (1996), 227-251.
- Brander, J. A., and P. Krugman, "A 'Reciprocal Dumping' Model of International Trade Policy," *Journal of International Economics*, XV (1983), 313-321.
- Card, D., "The Impact of Deregulation on the Employment and Wages of Airline Mechanics," *Industrial and Labor Relations Review*, XXXIX (1986), 527-538.
- Card, D., "Deregulation and Labor Earnings in the Airline Industry," Industrial Relations Section Working Paper No. 247, Princeton University, 1989.
- Christofides, L., and A. Oswald, "Real Wage Determination and Rent-Sharing in Collective Wage Agreements," *Quarterly Journal of Economics*, CVII (1992), 985-1002.
- Currie, J. and A. Harrison, "Sharing the Costs: the Impact of Trade Reform on Capital and Labor in Morocco," *Journal of Labor Economics*, XV (1997), S44-S72.
- Deardorff, A. and D. Hakura, "Trade and Wages- What are the Questions?" in Bhagwati, J., and M. Koster, *Trade and Wages: Leveling Wages Down?* Washington, D.C.: The American Enterprise Institute, 1994.
- Driffill, J., and F. van der Ploeg, "Trade Liberalisation with Imperfect Competition in Goods and Labour Markets," *Scandinavian Journal of Economics*, XCVII (1995), 223-243.
- Dunlop, J., *Wage Determination Under Trade Unions*, (New York, NY: A.M.Kelly, 1950).
- Ehrenberg, R. G., and R. S. Smith, *Modern Labor Economics*, (New York, NY: Addison-Wesley, 1997).
- Feliciano, Z., "Workers and Trade Liberalization: The impact of trade reforms in Mexico on wages and employment," *Industrial and Labor Relations Review*, LV (2001), 95-115.
- Freeman, R., "Spurts in Union Growth: Defining Moments in Social Processes," NBER Working Paper No. 6012, 1997.

Freeman, R., and L. Katz, "Industrial Wage and Employment Determination in an Open Economy," *Immigration, Trade, and the Labor Market*, J.M. Abowd and R. Freeman, eds. (Chicago, IL: University of Chicago Press, 1991).

Galiani, S. and P. Sanguinetti, "The Impact of Trade Liberalization on Wage Inequality: Evidence from Argentina," *Journal of Development Economics*, LXXII (2003), 497-513.

Hall, R. E., and D. M. Lilien, "Efficient Wage Bargains Under Uncertain Supply and Demand," *American Economic Review*, LXIX (1979), 868-879.

Hanson, G.H., and A. Harrison, "Trade, Technology and Wage Inequality," NBER Working Paper No. 5110, 1995.

Hanson, G.H., and A. Harrison, "Trade Liberalization and Wage Inequality in Mexico," *Industrial and Labor Relations Review*, LII (1999), 271-288.

Harrison, Ann. "Has Globalization Reduced Labor's Share? Some Cross-Country Evidence," University of California at Berkeley, mimeo, 2002.

Helpman, Elhanan and Paul Krugman, *Trade Policy and Market Structure*, (Cambridge: MIT Press, 1989).

Hicks, J. R., *The Theory of Wages*, (New York, NY: London: Macmillan, 1968).

Huizinga, H., "International Market Integration and Union Wage Bargaining," *Scandinavian Journal of Economics*, XCV (1993), 249-255.

Johnson, N. B., "Airline Workers' Earnings and Union Expenditures Under Deregulation," *Industrial and Labor Relations Review*, XLV (1991), 154-165.

Krugman, P., and R. Z. Lawrence, "Trade, Jobs and Wages," NBER Working Paper No. 4478, 1993.

Lawrence, C., and R. L. Lawrence, "Relative Wages in U.S. Manufacturing: an Endgame Interpretation," *Brookings Papers on Economic Activity*, No. 1, 1985.

Layard, R., S. Nickell and R. Jackman, *Unemployment: Macroeconomic Performance and the Labour Market*, (Oxford: Oxford University Press, 1991).

Levinsohn, J. "Testing the Imports-as-Market-Discipline Hypothesis," *Journal of International Economics*, XXXV (1993), 1-22.

Lundberg, S., and R. Pollak, "Separate Spheres Bargaining and the Marriage Market," *Journal of Political Economy*, CI (1993), 988-1010.

Marshall, A., *Principles of Economics*, (New York, NY: McMillan, 1949).

Macurdy, T. E., and J. Pencavel, "Testing Between Competing Models of Wage and Employment Determination in Unionized Markets," *Journal of Political Economy*, XCIV (1986), S3-S39.

Mezzetti, C. and E. Dinopoulos, "Domestic Unionization and Import Competition," *Journal of International Economics*, XXXI (1991), 79-100.

Munch, J.B. and J.R. Skaksen, "Product Market Integration and Wages in Unionized Countries," *Scandinavian Journal of Economics*, CIV (2002), 289-299.

Naylor, R., "International Trade and Economic Integration when Labor Markets are Generally Unionised," *European Economic Review*, XLII (1998), 1251-1267.

Nickell, S. J., Vainiomaki, and S. Wadhvani, "Wages and Product Market Power," *Economica*, LXI (1994), 457-473.

Oswald, A., "The Microeconomic Theory of the Trade Union," *The Economic Journal*, XCII (1982), 576-595.

Rama, M., and G. Tabellini, "Lobbying by Capital and Labor Over Trade and Labor Market Policies," *European Economic Review*, XLII (1998), 1295-1316.

Reddy, S., *Bargaining and Distribution: Essays on International Integration and National Regulation*, unpublished Ph.D. dissertation, Dept. of Economics, Harvard University, 2000.

Revenge, A. L., "Employment and Wage Effects of Trade Liberalization: The Case of Mexican Manufacturing," *Journal of Labor Economics*, XV (1997), S20-S43.

Richardson, J. D., and E. Khripounova, "Estimating the 'Market-Power' Component of International Trade's Impact on U.S. Labor," Syracuse University, unpublished working paper, 1996.

Rodriguez, F., and D. Ortega, "Trade Policy and Factor Prices: An Empirical Strategy," Wesleyan University and University of Maryland, unpublished working paper, 2006.

Rodrik, D., *Has Globalization Gone too Far?*, (Washington, D.C.: Institute for International Economics, 1997).

Rose, N. L., "Labor Rent-Sharing and Regulation: Evidence from the Trucking Industry," *Journal of Political Economy*, XCV (1987), 1146-1178.

Skillman, G. "The Impact of Liberalization on Wage Levels: Considerations Raised by Strategic Bargaining Analysis," Wesleyan University, unpublished paper, 2000.

Slaughter, M., "International Trade and Labor-Demand Elasticities," *Journal of International Economics*, LIV (2001), 27-56.

Slaughter, M., "What are the Results of Product-Price Studies and What Can We Learn From Their Differences?" in Robert C. Feenstra ed. *The Impact of International Trade on Wages*, NBER Conference Volume (2000), 284-291.

Slaughter, M., "International Trade and Labor-Market Outcomes: Results, Questions and Policy Options," *The Economic Journal*, CVIII (1998), 1452-1462.

Slichter, S., "Notes on the Structure of Wages," *Review of Economics and Statistics*, XXXII (1950), 80-91.

Svejnar, J., "Bargaining Power, Fear of Disagreement, and Wage Settlements: Theory and Evidence from U.S. Industry", *Econometrica*, LVI (1986), pp. 1055-1074.