

The goal of this white paper is to explain Class-D amplifiers and PowerPhysics' approach to designing and building them. We have written several papers for engineers skilled in the art of amplifier design, but the intent of this paper is to walk through the basics using first level approximations and analogies.

Class-D amplifiers are not digital, they just happened along following Class-C. The difference between a Class-D or switching amplifier and most other audio amplifiers (Class A, Class-A/B or rarely Class-B) is the way that the output transistors are used. In Class-D the transistors are either on or off, just like a light switch. To grasp what's happening in a switching amplifier let's follow the light switch metaphor and imagine inventing a new light dimmer switch. We won't do anything you have seen before, this dimmer will be special. It operates for one minute at a time, a sixty second *period*. At the beginning of the minute the Operator determines how many seconds the switch will be on. Zero equals darkness. Sixty is full bright. And 30 seconds is half bright, 15 second is quarter bright, etc.

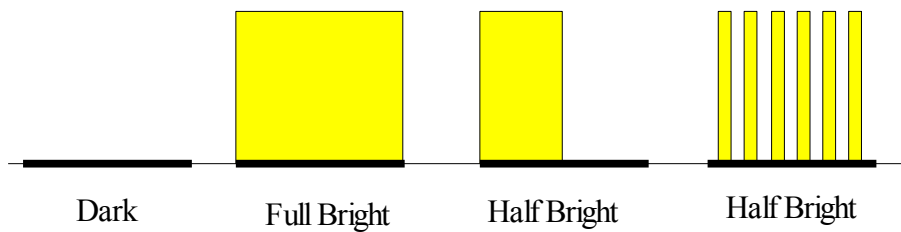

Now our first design wouldn't work very well because one minute is just too long a period. We don't want half bright (or half power) to be 30 seconds of light and 30 seconds of darkness, so we change the period or *cycle* from one-minute to something really small like one thousandth of a thousandth of a second. This concept is shown in the far right of the drawing. Now half bright really appears to be dimmer. The light is still off half of the time, but we can't tell because everything switches so fast there is no flicker. The same reasoning applies to audio amplifiers and what engineers call *pulse width modulation* or PWM.

In the other audio amplifier classes the output transistors (or tubes) operate more like water valves not switches. Open the valve just a little bit and get a little bit out. Open it more, get more. If the valve action is linear then you have an amplifier. Now if this completely defined how linear systems worked, then we wouldn't bother with Class-D, so we know there is a "however." In this case we need to modify our assumptions about the valve and make it a diverter valve.

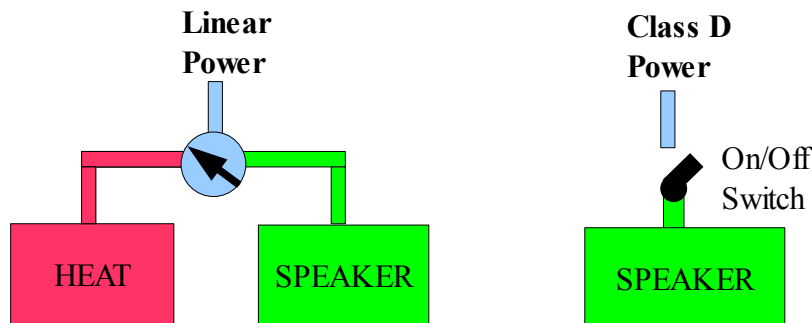

Topic: **PowerPhysics' Approach to Class-D Amplifiers** *Understanding One-Cycle Sound*

Imagine power, just like water, flowing into the amplifier valve. It can be sent to the speaker tank or the heat tank. Any power that isn't used in the speaker must be sent into the heat tank, or in a real linear amplifier, the heat sink and then into the air. This is a tremendous difference from Class-D where there is a true on/off switch and only the power that is needed is used. Because Class-D amplifiers don't convert unused power into heat, they are more *efficient* than linear amplifiers. This explains why high power amplifiers can fit into such small chassis. The need for a heat sink is drastically reduced. Class-D amplifiers turn the old weight equals quality axiom on its head.

The efficiency of Class-D amplifiers has benefits beyond reducing weight and heat. It stands to reason that if the amplifier only uses the power it needs, we can give it lots of power without paying a penalty. In more technical terms, we can increase the amplifier *headroom* by using a high bus voltage. This allows the amplifier to instantaneously pass transient signals without clipping.

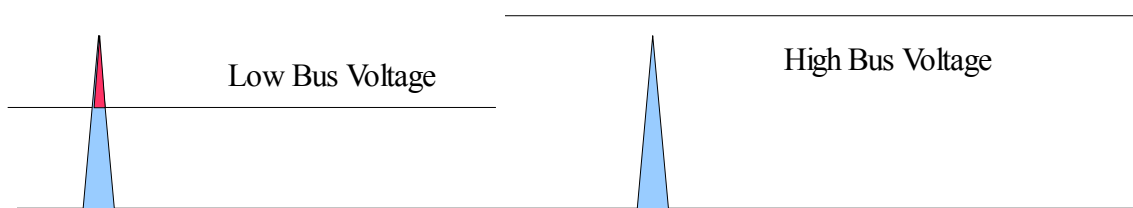

So far we have discussed the advantages of Class D amplifiers compared to the other classes of amplifiers. Now it is time to discuss the differences between PowerPhysics One-Cycle Sound Class-D amplifiers and other Class-D amplifiers. One-Cycle Sound is PowerPhysics patented method of generating the pulse width modulation needed by Class-D amplifiers. It is the optimal control law for controlling the “brightness” we discussed earlier in the design of our light dimmer.

The figure below contains all of the component blocks of the latest generation of PowerPhysics' One-Cycle Sound Class D switching amplifier.

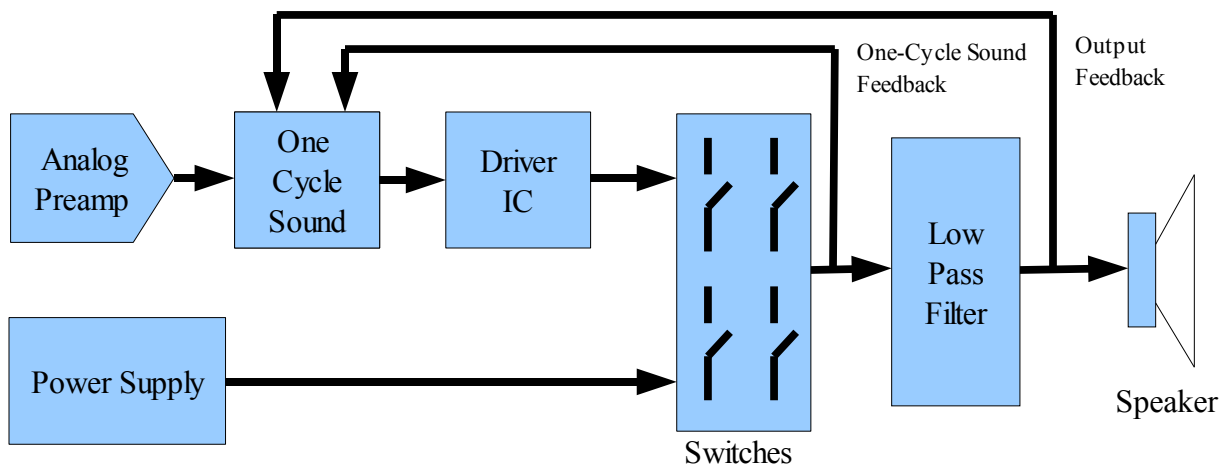

We will step through this block diagram following the path of the audio signal. At the beginning of the signal flow is the Analog Preamplifier. This component is common to amplifiers of all classes. Our design uses a high quality differential input to reduce *common mode* noise. Common mode means that a signal is on both inputs, which is typically true of hum and buzz. If any capacitors are required in the audio path, we specify film. Electrolytic capacitors are only used for power storage and bypass. The preamplifier is small and clean. We do not attempt any filtering here other than DC blocking.

From the preamplifier, the audio signal enters the the One-Cycle Sound block, the most important. Any component in the audio path can degrade sound quality, but here in the One-Cycle Sound circuitry we can take measurements that allow us to optimize the energy in our pulse width modulation signal. We will cover this process in more detail later. For now it is only important to note all the information available to One-Cycle Sound and that we introduce as little error as possible and remove it faster than any other Class-D topology.

Once the audio signal is converted to a PWM signal it is input to the Driver IC. Many people mistakenly believe that the Driver is responsible for creating the PWM signal because it is usually one of the larger chips on the board. The Driver is just a convenient integrated circuit designed to control the output switches. Given a mediocre PWM signal it slavishly controls the switches to a mediocre result. PowerPhysics has built amplifiers using several different manufactures of Drivers. We select Drivers that give good control of *dead time*. The very small period of time when all of the Switches are off and there is zero output to the speaker. Dead time is required, but it also causes distortion in Class-D amplifiers that require perfect PWM waveforms. One-Cycle Sound compensates for dead time.

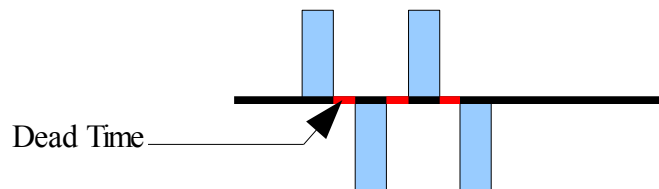

The Switches are, like the Driver, critical to the final design, yet not indicative of a good or bad design all by themselves. There are many MOSFETs available that can be used in Class-D amplifiers. All of the current that passes through the speaker will be controlled by the Switches. They must be capable of handling this current and more to assure the design is robust. The Switches are also where Class-D amplifiers generate most of their heat. Even though this is small compared to a Class A, A/B or B amplifiers the Switches must be selected with care. There are two primary ways that the Switches lose energy and create heat: *conduction losses* and *switching losses*. Conduction losses occur when the switch is closed. There is a small resistance to current flow inside the Switch that causes it to heat.



Closed Switch



Open Switch

POWERPHYSICS Technical Memo	Date: 23 NOV 07	Author: G K Wanlass	Page: 4 Of 6
Topic: PowerPhysics' Approach to Class-D Amplifiers <i>Understanding One-Cycle Sound</i>			

An open Switch looks like a capacitor. It charges up during the period of time it is held open and then discharges the moment it is closed. These losses are called *switching losses* and are function of the MOSFET's body diode capacitance, the voltage level when it is charged and the number of times it switches per second which is called *switching frequency*. This energy is usually lost. There are circuits called *soft-switching* circuits can recover it, but a discussion of these methods is too cumbersome for this paper. Once a MOSFET is selected for an amplifier design it becomes a sole-source part which means that it can only be purchased from one manufacturer. This assures that all of the engineer's work is preserved during production. One-Cycle Sound is very forgiving of the PWM waveform and does not require perfectly square pulses with ideal timing, and its a good thing because no switch is ideal.

Before reaching the speaker, the fully amplified audio signal passes through a Low-Pass Filter which is often called a reconstruction or output filter. Its purpose is to reduce the high frequency components of the PWM signal to avoid electromagnetic radiation and possible heating of the speaker driver. By design this filter does not affect any signal below 50 kilo-Hertz, which is well above the audio bandwidth. However, we pay attention to the filter linearity to assure that distortion is minimized. The filter also tends to increase the amplifier output impedance which is a critical variable in calculating *damping factor* or *damping ratio*: the impedance of the load divided by the amplifier's output impedance. To increase the damping ratio and reduce the amplifier's sensitivity to load impedance PowerPhysics' latest generation amplifiers have an output feedback loop with a relatively low gain to avoid changing the audio quality. Feedback is a very useful tool and a key reason why high power amplifiers are analog. (Digital feedback loops are still in the research stage for the most part.) But, we don't want to use more than we need.

The power supply of an audio system should never be taken for granted. It is a very important part of amplifying an audio signal with high fidelity. It has to store energy to keep the low end nice and tight. It must provide a nice high bus voltage for passing high peak power transient signals. Notice that *regulation* or the amount of change of the bus voltage was not mentioned. In most amplifier this is an essential specification, but not for One-Cycle Sound. And here's why:

One-Cycle Sound ends a switching cycle when the difference between the audio signal and the PWM waveform is zero.

This is a very powerful concept. To understand its power, we will step through all of the errors that creep into a Class-D amplifier system and show how One-Cycle Sound corrects them. The first error we will tackle is power supply regulation. Suppose that the power supply dropped from 100V to 90V. What would happen? In our dimmer example it is easy to imagine that the light would be dimmer than we expected. Our pulses were supposed to be 100 Volts tall, but they were only 90 Volts tall, so we lost ten percent and the room is darker.

It makes sense that if we knew the pulses were short we could have made them wider to get more light and that is exactly what One-Cycle Sound can do. Go back to the block diagram an look at the inputs to

the One-Cycle Sound block. The PWM waveform is a direct input. One-Cycle Sound knows exactly how “tall” each pulse is. This example is shown in the following figure.

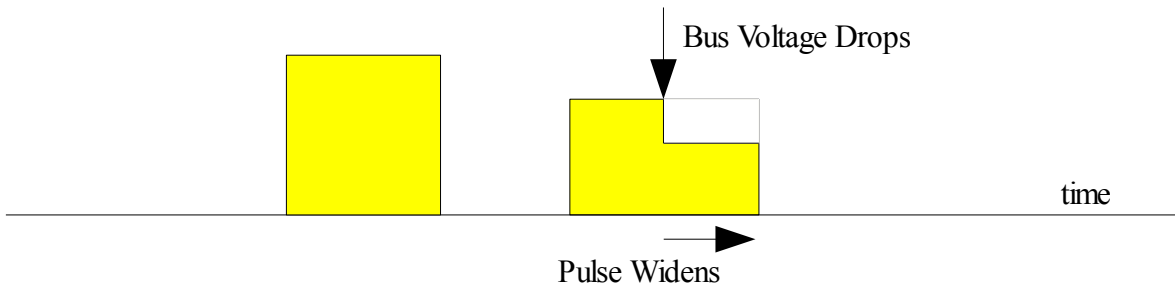

One-Cycle Sound is looking at the average or basically the area under the curve which is colored yellow above. In the example of our dimmer switch we measure it against a standard of brightness in our heads because we know how bright a room should be. If the area of yellow is the same between the two pulses then the pulse ends. An audio amplifier is more complex, but the concept of removing error is the same.

The figure below compares ideal and real PWM signals. PWM amplifier signals have to move a speaker in two directions, so unlike our dimmer, they have positive and negative voltages. In the example below the upper and lower blocks are voltage that can be applied to the speaker. The upper block pushes it forward and the lower block pulls it back. If the two blocks are equal then the speaker does not move because the average is zero. (Remember these blocks are a very very small amount of time and it takes a lot of them together to move the speaker.)

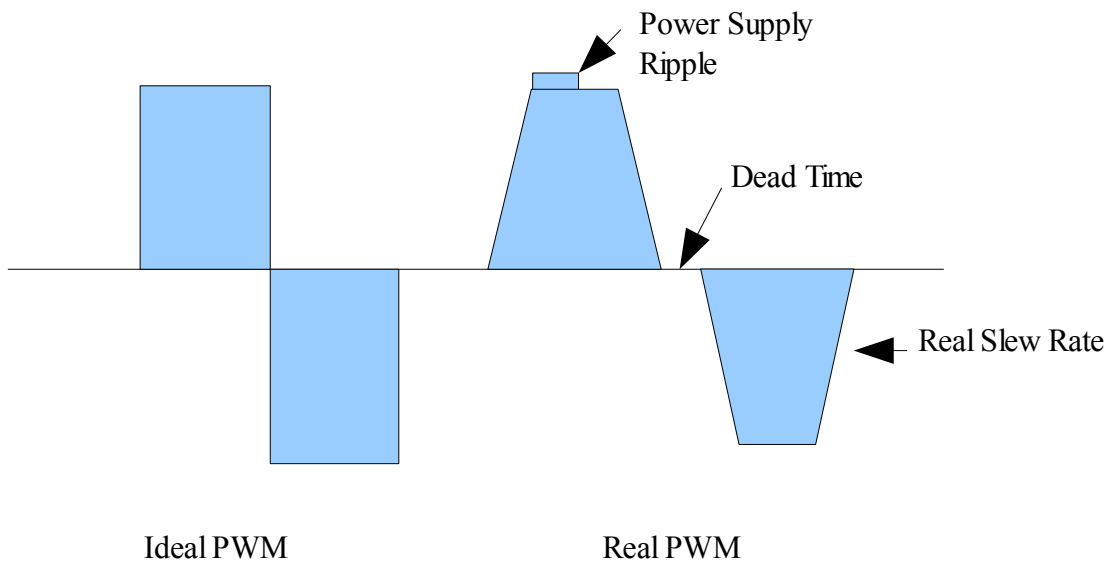

POWERPHYSICS Technical Memo	Date: 23 NOV 07	Author: G K Wanlass	Page: 6 Of 6
Topic: PowerPhysics' Approach to Class-D Amplifiers <i>Understanding One-Cycle Sound</i>			

If the amplifier makes any assumptions about the PWM wave form, then it will be subject to distortion. Most of the Class-D single chip amplifiers are open loop (no feedback) assume a perfect PWM generation circuit. It's just not going to happen. As you can see above real PWM is full of errors. Power supplies ripple and sag, the output circuit must have dead time to avoid shorting, MOSFETs have limited slew rate and they are not identical. The list goes on and on, temperatures vary, circuits have tolerances. Any assumption will lead to error.

It also stands to reason that the longer an error exists, the more damage it does to sound quality. The primary goal of One-Cycle Sound is to track the audio signal compare it to the real PWM waveform and end the cycle when error is zero. Error is driven to zero and the audio input is monitored about 300,000 times per second. No PWM control law works faster and that's the secret behind One-Cycle Sound.