

# TWA News

Volume XXI  
Issue 5  
May 2004

Newsletter of the Triangle Woodworkers Association

## NEXT MEETING DATE

**May 18, 2004**

**The Woodworking Shop  
3141 Capital Blvd**

**Tuesday, May 18th meeting.  
Cabinetmaking: Construction  
Standards and Story Sticks**

Following a very successful 2003 program on router jigs, Hal Brown returns to present his own approach to building traditional cabinets. Hal has learned how to efficiently build kitchen cabinets, bathroom vanities, and entertainment centers by standardizing his construction techniques. Only the length, or run, of the cabinets is needed to fit his cabinets to any job site, for which he uses a story pole to record his measurements. Hal will show how he uses his construction techniques and a story pole to build quality products and a rewarding business.

Background: Hal Brown has had a twenty five year career in healthcare. Hal retired in 1995 from Rex Hospital, in Raleigh, as Director of Cardio and Pulmonary Services. With an interest in woodworking stretching back to his childhood in bible school, Hal became a professional cabinetmaker upon his retirement. Hal receives commissions ranging from kitchen cabinet installations to custom furniture. Hosted by Robert Foss Telephone 782-6472

### Lon Schleining workshop

The work shop on April 23,25 was a great success. We had 19 participants with a good combination of demonstrations and hands on. We almost completed the chest and learned many techniques and processes from design, joinery, glue up and assembly. Thanks to all who participated and did the clean up. Dave Mackie

## President's Corner

Again, thanks to our program committee, we had an excellent program at our April 23 meeting. Lon Schleining makes an outstanding presentation that everyone has to enjoy.

The arbor project with the Audubon Society is making headway. We have decided to obtain the treated wood from Tarheel Wood Treating Co. They will give use contractor prices and their wood is good. I plan to get the hardware from Home Depot where the Audubon Society will set up an account for me. I will probably start in a few weeks. -Hal Liberty

## Toys for Tots Program

APO Fraternity from NC State came to my shop on April 24 and worked on toys. I had them do sanding and finishing. I now have a good number of toys ready for final finish and adding of wheels. This will be a good job for the senior citizen center.

Rick Cornell suggested that I offer my services as a mentor. I agree that this is a good idea and can go along with the Toys for Tots program. I have nearly every type of hand and power tool. I can teach people how to use them and they can practice on making toys. I am usually at my shop everyday. I am also at my shop on Saturday mornings when I have a workshop. -Hal Liberty

## June 15th TWA Meeting Spraying Finishes



June's meeting will have an emphasis on water based finishes. We will be taught by George Holmes of Traveler's Rest SC. George is employed by the M L Campbell Co. George regularly conducts school for professionals in Charlotte. Hosted by Bruce Wrenn Telephone 362-0878

## About the Triangle Woodworkers Association

The Triangle Woodworkers Association (TWA) is a non-profit educational corporation. The TWA is dedicated to teaching woodworking techniques through seminars, classes, and workshops; participants are required to sign waivers absolving liability for TWA or its designated representatives. The TWA promotes woodworking education and community interest in woodworking and in general sharing a love for wood.

### Club Officers and Committee Chairmen

#### Executive Board

President: Hal Liberty, 919-787-7603 or hal\_liberty@hotmail.com  
 Vice President: Bob Gabor, 919-542-5951 or rjgwood@mindspring.com  
 Secretary: Kay Baker, 919-662-8504, kaybaker@nc.rr.com  
 Treasurer: Noel Butzke, (919) 233-2905  
 Members at Large: Dick Courtney, Robert Foss, Sig Johnson

#### Committee Chairman

Program: Bob Gabor, 919-542-5951 or rjgwood@mindspring.com  
 Nominating: Fred Ford, 919-469-9575 or fwford@bellsouth.net  
 Toys for Tots: Hal Liberty, 919-787-7603  
 Newsletter: Rick Cornell, 919-319-9980 or trianglewoodworkers@yahoo.com  
 Library: Kay Baker, 919-662-8504  
 Publicity: Ron Johnson, 919-544-2021  
 Sponsor: Ed Karolak, 919-383-4233  
 Hospitality: Jim Morrison, 919-851-4384  
 Internet: Jim Kroeger, (919) 362-5741  
 Mentor: Dave Mackie, 919-859-2600 or mackieevad@aol.com  
 Photograph: Ron Heidenreich, 919-848-1134  
 Membership: Rick Cornell or 919-319-9980 Trianglewoodworkers@yahoo.com  
 Audio: Tom Revelle, 919-387-8286

TWA News is published monthly by the TWA and is mailed to members, sponsors, and associates. If you are interested in contributing articles, please send to:

Triangle Woodworkers Association  
 P.O. Box 4206  
 Cary, North Carolina 27510-4206

or trianglewoodworkers@yahoo.com



**Deadline for submitting articles and classified ads to the next newsletter is:**

**June 1, 2004**

## On the Web

In an effort to make our web site more useful, we have made several enhancements. We now offer:

- “Info” - which contains several charts and information useful in woodworking.
- “Plans” - a section contain various types of plans for woodworking projects.
- “Web Links” - several internet sites for other woodworking clubs. See what others are doing in their clubs.

We would like your contributions as well. If you have informational charts or plans, please contact us. Rick Cornell has offered to scan paper plans to an electronic format, providing they are given to him on 8 1/2 x 11 paper. Plans should be drawn or written in black or blue ink to make it easier for scanning.

You may also find the contents of our ever growing library on the site as well. Remember:  
[www.ibiblio.org/twa](http://www.ibiblio.org/twa)

### Treasurer's Report

Balance 4/1/04	\$7,188.35
Income	\$1,219.00
Expenses	\$1,758.42
Ending Balance 4/30/04	\$6,648.93

Respectfully submitted,  
 Noel Butzke, Treasurer

#### TWA Financial Report As of 4/30/2004

	Apr Actual	YTD Actual	2004 BUDGET
<b>Beginning Balance</b>	<b>7188.35</b>	<b>6528.15</b>	<b>6528.15</b>
<b>INCOME</b>			
Dues	1219.00	2,184.00	6,000
<b>TOTAL INCOME</b>	<b>1219.00</b>	<b>2184.00</b>	<b>6,000</b>
<b>EXPENSE</b>			
Workshops/Programs	1,893.55	3,242.92	3,500.00
Income	-380.00	-1,870.00	
Newsletter	91.47	258.68	1,000.00
Equipment	0.00	0.00	100.00
WEB	70.00	100.00	430.00
Meeting Exp	0.00	0.00	140.00
Administrative	83.40	121.19	500.00
Library Exp	0.00	210.43	650.00
Toys-Tots	0.00	0.00	200.00
<b>TOTAL EXPENSES</b>	<b>1758.42</b>	<b>2063.22</b>	<b>6,520</b>
<b>Ending Balance</b>	<b>6648.93</b>	<b>6648.93</b>	<b>6008.15</b>

**TWA Meeting Minutes  
Friday, April 23, 2004**

The meeting was opened by Hal Liberty, President, at 7:30 at the Woodworking Shop on Capital Blvd.

One visitor was introduced.

Paul Rolf, manager of the Woodworking Shop, announced that Tom Wolf, one of the premier carvers in the United States, will be teaching caricature carving at the Woodworking Shop. He will be in the store April 30, May 1 and 2.

Beginning next month the register will close at 8:00 pm. Purchases can still be made but a manual ticket will have to be written. Hal said that he just bought a Shop Fox dust collector from the shop and it works great. It has remote control and all you have to do is plug it in.

Bruce Wrenn brought back three pieces of 3/8 inch glass from Savannah. He is selling it for \$12.00 each. Bruce explained trying to level his Unisaw in his shop by using a 5/8" flat washer under a carriage bolt. It will fit a standard caster cup and ride up and down on it instead of using the regular \$30.00 levelers

Hal took toys to the Senior Citizens Center to have them painted. Next week he will take them back for the second coat. Tomorrow he has a fraternity coming to help sand. He has decided to make his Saturday workshops 8:30 to 12:30 except when TWA comes so that he can have some time off.

Dave Mackie introduced the speaker, Lon Schleinig, from California, who writes for Fine Woodworking, and has written several books. He presented a slide show on workbenches. He has just finished a book which has been sent for publication and will probably be released in the fall but will become available in August. You can go to his web site ([woodbender.com](http://woodbender.com)) to order an auto-graphed copy. In the process of doing the book he visited many shops including Kelly Mehler, Brian Boggs, and James Krenov.

There were 51 people present at the meeting.

The meeting was adjourned at 9:30 p.m.

Submitted by Kay Baker, Secretary

**Library Tidbits  
Drills and Drill Presses**

Until now we didn't have a book dedicated to drill presses but amongst our new books we acquired Drills and Drill Presses by Rick Peters. This is a soft bound book with 128 pages of information on different types of drills and drill presses, attachments, and jigs to make them even more useful. There is a section on maintenance, and one on troubleshooting. Various types of bits and screws are explained along with shank styles. He includes everything from anatomy to tips. Have you ever thought of putting the bit through a cup to catch the dust when drill in a ceiling? That's one of the many tips from Rick Peters. It will be available for check-out at the next meeting.

**"Help Wanted"**

I have a piece of mahogany 22" x 3" x 78" that has a table inside of it. Does anyone have a device that can resaw this board? Anyone suggesting a two-man saw need not reply. greg gittins, 302-4499, [ggittins@mindspring.com](mailto:ggittins@mindspring.com)

\* \* \* \* \*

I have a very large oak tree, (white-red???), in my back yard. The builder has cut quite a few of the roots during construction. It appears to have a lean to it, towards the house, not a good thing. It is about six-seven feet from and centered on our screened in porch. I would like to get it taken down, but I would also like to keep most of the wood or building "stuff" not firewood. I called and had an estimate, the person wanted 2250.00 to take it down, stump grind, mulch what could be mulched, haul off the rest along with two pieces of pine 8' and 10' x 22" in diameter. The pine I don't believe I can use, but I think "when" it dries out the oak would be better used for making something rather than firewood. Any suggestions? Portable sawmill any- where near my area, drying the wood, getting the tree down. Thanks, Dwight G. Frazer, (919) 367-7357

\* \* \* \* \*

I just joined TWA. I live in Chapel Hill, and would like to know if anyone is aware of woodworking clubs or classes in the Chapel Hill and/or Durham area. Jonathan Brimfield, (919) 345-5656, [jbrimfie@cisco.com](mailto:jbrimfie@cisco.com)

## Best Place for Woodworkers to Live

By Bruce Wrenn

Recent survey of Bruce Wrenn ranks Raleigh/Durham/Chapel Hill area as #1 place to be a woodworker. First, let's start with toy, I mean, tool stores. We have three premium woodworking stores within 50 miles of each other. There's Klingspor's Woodworking Shop, Woodcraft and Woodworker's Supply, plus Tarheel Filing and Dillon Supply Co. Need wood? There is Klingspor's, Woodcraft, Raleigh Hardwood Center and Moncure Plywood. Gibsonville Hardwoods and Steve Wall Lumber are about an hour's drive. Want local wood? Try American Wood Yard, Mike Robbins or others. Need metal? Try Dillon Supply or Lee iron and Metal (Sanford & Raleigh) plus TT&E of Garner. Need bolts or screws? Try Agri Supply in Garner or one of the local Ace Hardware's. Need some flex hose for dust collection, try Raleigh Durham Rubber & Gasket. Want used tools? Check out the State Fairgrounds flea market plus several pawn shops. Check bulletin boards at tool stores plus check News & Observer want ads. Want to compare band saw mills, check out Southern Farm Show. Need help? Try Triangle Woodworkers Association or Triangle Woodturners. Where else can you live where commercial cabinet makers will take a few moments to visit and chew the fat. Need a sawblade sharpened, we have both Ashcrofts and Raleigh Saw. Power tool broken? We have DeWalt, ABC Powertool & Specialty Tool Service. Sure RDU doesn't have the pedigree of Baston or Philthydelphia, but this is a great place to be a woodworker and there are some great woodworkers here!

\*\*\*\*\*

Tip: When making cope and stick frames, leave your blank for the rails big enough to be ripped into two rails. Cope the ends, then rip into two rails. A perfect match for length every time.

## Unisaw Leveling

-Bruce Wrenn

Recently, I started rearranging my shop. My Unisaw would be put on the left side, instead of in the center bay. One problem, the floor slopes to a floor drain. I priced a set of leveling feet to go under my saw (about \$80 for the cheapest set of r). I considered using carriage bolts as leveling legs, but realized that their small bearing area would soon dig into the concrete floor. Soon the light came on as to how to make an adjustable leveling foot! (See drawing). By allowing the head of the carriage bolt to rest in a washer, the washer would pivot to compensate for the uneven floor. The rubber caster cup prevents sliding and the washer spreads the weight out over a larger area. I could use a wrench on the square shoulder of the carriage bolt to adjust the height and then lock it with the jamb nut.

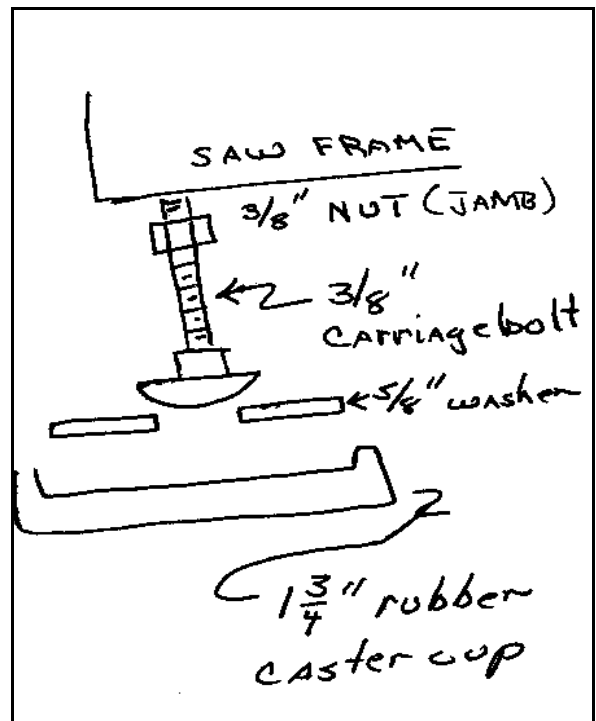

**Remember - We no longer use the RTP address for membership applications and renewals. Please send to the Cary address printed on the last page of the newsletter!**

## TWA Sponsors

Ashcroft Saws and Tools 876-3223  
3216-G Wellington Ct, Raleigh, NC  
25% off list on blades and 10% off on sharpening

Capitol City Lumber Co. 832-6492  
4216 Beryl Road, Raleigh, NC 1-800-244-6492  
Special prices to TWA members  
<http://www.capitolcitylumber.com/>

Carolina Builders 828-7471  
3000 Yonkers Rd  
Hwy. 64 & Old US 1

Guy C. Lee Building Materials 362-1444  
900 N. Salem St., Apex, NC

Klingspor's Sanding Catalog 800-228-0000  
P.O. Box 3737, Hickory, NC 28603  
10% discount excluding lumber and power tools  
[www.sandingcatalog.com](http://www.sandingcatalog.com)

The Woodworking Shop (919) 876-0707  
3141 Capital Blvd. (.9 mile N of Beltline exit 11)  
(10% discount excluding lumber and power tools)  
[www.woodworkingshop.com](http://www.woodworkingshop.com)

Raleigh Hardwood Center 231-6620  
4213 Poole Rd, exit 15 off 440 Raleigh, NC  
(10% discount all non-sale items)  
[www.hardwoodgroup.com](http://www.hardwoodgroup.com)

Raleigh Saw 832-2248  
806 McCulloch Street, Raleigh, NC  
(10% discounts on all new products)

Tarheel Wood Treating Co. 467-9176  
Highway 54, Morrisville, NC  
(Contractors prices on all wood products)  
Show TWA card before order is written

Tarheel Wood Treating Co. 467-9176  
Highway 54, Morrisville, NC  
(Contractors prices on all wood products)  
Show TWA card before order is written

The Hardwood Store 1-888-445-7335  
Gibsonville, NC  
Discount: 10 cents per board foot  
[www.hardwoodstore.com](http://www.hardwoodstore.com)

Woodworker's Supply of NC  
1125 Jay Lane, Graham, NC  
(Wholesale prices)  
store (336) 578-0500  
mail order 1-800-645-9292  
[www.woodworker.com](http://www.woodworker.com)

Yarnell-Hoffer Hardware 942-3500  
145 Rams Plaza, Chapel Hill, NC  
[www.doitbest.com/yh](http://www.doitbest.com/yh)  
10% discount except power tools and sale items

Professional Tool Manufacturing  
[www.drilldoctor.com](http://www.drilldoctor.com)  
25% Discount for online purchase of any Drill Doctor. Must use coupon code: TWAi  
Contact [wms@protoolmfg.com](mailto:wms@protoolmfg.com) with any questions.

The following companies do not provide discounts to Members but support TWA and our programs in other ways:

Home Depot DeWalt Tools

\* \* \* \* \*

*Members, sponsors and potential sponsors are invited to contact Ed Karolak with their ideas, questions, or concerns at [Ekarolak@aol.com](mailto:Ekarolak@aol.com) or call at 919-383-4233*

### **\$ CLASSIFIED ADS \$**

Classified ads are free to all current members. If you would like something listed, please send a note to the editor at [TriangleWoodworkers@yahoo.com](mailto:TriangleWoodworkers@yahoo.com)

**Lumber For Sale:** Furniture Grade: White & Red Oak #1 Common \$1.00 B.F. Clear \$2.00 to \$2.50 B.F. 3' - 16' long up to 12" wide. Poplar #1 Common 70 cents B.F. Clear \$1.50 B.F. Also colorful Hickory, Soft Maple & Walnut. A little left of Planed & Kiln dried. Quantity discount. Arlin Scott 967-6017 prefer you call evenings. Chapel Hill

**For Sale:** Performax ShopPro 25 Sander, like new (less than 10 hrs use); mobile caster base, 1/2 box 100 grit paper. \$1400.0 919-796-4919 Hal Brown

**For Sale:** Delta 10 Inch Deluxe Radial Arm Saw. Excellent Condition with 80 tooth Freud blade . Like new asking \$295. Fred Alphin, (919) 782-2180, [alphinf@ncfb.com](mailto:alphinf@ncfb.com)

**For Sale:** Radial arm saw – 10" Black & Decker 120 volts, 3450 RPM, Serial #22000520. Includes heavy metal stand. \$175 Call Kay Baker 696-8504 (cell)

TWA

**Membership Application**

Complete and mail to:

Triangle Woodworkers Association  
P.O. Box 4206  
Cary, North Carolina 27519-4206

Name: \_\_\_\_\_

Address: \_\_\_\_\_

City: \_\_\_\_\_ State: \_\_\_\_\_ Zip: \_\_\_\_\_

Phone: \_\_\_\_\_ E-mail: \_\_\_\_\_

Spouse's name, if joining (fee is \$1.00): \_\_\_\_\_

Skill level:      Beginner [ ]    Intermediate [ ]    Advanced [ ]    Professional [ ]

**New member- email newsletter \$30.00 [ ]**

**New Member – hard copy newsletter \$35.00 [ ]**

**Renewal – email newsletter    \$25.00 [ ]**

**Renewal – hard copy newsletter    \$30.00 [ ]**

**Check #** \_\_\_\_\_

**Cash** Amount \_\_\_\_\_ (Do not send cash through mail!)

**Privacy Opt-Outs:** Please Do NOT Publish My [ ] Phone Number [ ] Email Address on Membership lists. (Note: This means your phone and email information will be used only for club correspondence by club officers and committee chairman)

**MEMBERSHIP EXPIRED?**

*Check the mailing label, for the expiration date of your membership. If it says EXPIRED, please contact our membership coordinator to renew. You may receive several newsletters past your expiration date and then no more. If you have a question about your membership, please contact Rick Cornell (919-319-9980).*



Triangle Woodworkers Association  
P.O. Box 4206  
Cary, North Carolina 27519-4206