

# TWA News

Volume XXI  
Issue 7  
July 2004

Newsletter of the Triangle Woodworkers Association

## NEXT MEETING DATE

**July 20, 2004**

**The Woodworking Shop  
3141 Capital Blvd**

### July Meeting Program Furniture Design

Presented by master woodworker and furniture designer David Kenealy. He has been on the faculty of Rockingham Community College since 1987. In addition to being the direct and lead instructor at Rockingham, he took two sabbaticals and engaged in a number of interesting experiences. He lived in Cebu, Phillipines for one year as director of quality control for Maitland-Smith, Inc. and for another year was director of quality control, engineering, and sample making at Maitland-Smith, Inc. On another one year assignment, he was in Mandawa, India as plant manager for Highland Home Furniture Company. He is also owner of Kenealy Enterprises, specializing in sample work consulting for the furniture industry. David and his students display their magnificent furniture at many of the national tool shows. The pieces are great examples of innovative design and superb craftsmanship. His presentation to TWA will be a must-see program! David will take us from concept, to material selection, to finished work of art! Hosted by Ed Karolak Telephone 383-4233

### August Meeting Program Proper Dust Control in Your Shop

Presented by Bruce Wrenn. Bruce needs little introduction to most club members but for those of you who may be new to the club or do not follow the newsletter closely, Bruce is a former shop teacher and is well versed on many subjects. From his articles of Tool Talk in our newsletter, most of us have picked up many helpful tips for our shops. Bruce has helped to set up others with dust collection systems that would parallel even "Norm's". Please join us for an informative and entertaining meeting. Hosted by John Cramer Telephone 844-4087

### Cyclone Workshop August 21st

To accompany the August program on dust control in the workshop, Bruce will conduct a workshop on Saturday, August 21st on building your own cyclone dust collector. The cost will be \$175, and is open to TWA members only. You will need to purchase a metal trash can (Lowes—30 gallon). The workshop will be limited to a minimum of 5 and a maximum of 10. This workshop normally costs \$250 and reservations are due by Saturday July 31st. Contact Bruce Wrenn, 362-0878 if you need additional information.



### In Memoriam

As many of you are aware, Dick Hall, who has been a member of TWA for many years died on May 11. Dick had been an orthopedic surgeon and a pilot. Dick gave up these two activities after becoming blind and became very involved with woodworking. He continued to make toys for the Toys for Tots program. Last year, he provided over 600 cars that were ready for final sanding and finishing. He provided the wheels and axles. He also made toys and other articles for his family and friends.

I received a very nice note from his wife Joan thanking us for the card we sent that had many of the TWA member's signatures. His contribution to the Toys for Tots program and absence for TWA will be missed. - Hal Liberty

## About the Triangle Woodworkers Association

The Triangle Woodworkers Association (TWA) is a non-profit educational corporation. The TWA is dedicated to teaching woodworking techniques through seminars, classes, and workshops; participants are required to sign waivers absolving liability for TWA or its designated representatives. The TWA promotes woodworking education and community interest in woodworking and in general sharing a love for wood.

### Club Officers and Committee Chairmen

#### Executive Board

President: Hal Liberty, 919-787-7603 or hal\_liberty@hotmail.com  
 Vice President: Bob Gabor, 919-542-5951 or rjgwood@mindspring.com  
 Secretary: Kay Baker, 919-662-8504, kaybaker@nc.rr.com  
 Treasurer: Noel Butzke, (919) 233-2905  
 Members at Large: Dick Courtney, Robert Foss, Sig Johnson

#### Committee Chairman

Program: Bob Gabor, 919-542-5951 or rjgwood@mindspring.com  
 Nominating: Fred Ford, 919-469-9575 or fwford@bellsouth.net  
 Toys for Tots: Hal Liberty, 919-787-7603  
 Newsletter: Rick Cornell, 919-319-9980 or trianglewoodworkers@yahoo.com  
 Library: Kay Baker, 919-662-8504  
 Publicity: Ron Johnson, 919-544-2021  
 Sponsor: Ed Karolak, 919-383-4233  
 Hospitality: Jim Morrison, 919-851-4384  
 Internet: Jim Kroeger, (919) 362-5741  
 Mentor: Dave Mackie, 919-859-2600 or mackieevad@aol.com  
 Photograph: Ron Heidenreich, 919-848-1134  
 Membership: Rick Cornell or 919-319-9980 Trianglewoodworkers@yahoo.com  
 Audio: Tom Revelle, 919-387-8286

TWA News is published monthly by the TWA and is mailed to members, sponsors, and associates. If you are interested in contributing articles, please send to:

Triangle Woodworkers Association  
 P.O. Box 4206  
 Cary, North Carolina 27519-4206

or trianglewoodworkers@yahoo.com



**Deadline for submitting articles and classified ads to the next newsletter is:**

**August 1, 2004**

## On the Web

In an effort to make our web site more useful, we have made several enhancements. We now offer:

- “Info” - which contains several charts and information useful in woodworking.
- “Plans” - a section contain various types of plans for woodworking projects.
- “Web Links” - several internet sites for other woodworking clubs. See what others are doing in their clubs.

We would like your contributions as well. If you have informational charts or plans, please contact us. Rick Cornell has offered to scan paper plans to an electronic format, providing they are given to him on 8 1/2 x 11 paper. Plans should be drawn or written in black or blue ink to make it easier for scanning.

You may also find the contents of our ever growing library on the site as well. Remember:  
[www.ibiblio.org/twa](http://www.ibiblio.org/twa)

### Treasurer's Report

Balance 6/1/04 \$7,045.72\*  
 Income \$302.00  
 Expenses \$375.91  
 Balance 6/30/04 \$6,971.81  
 \* Adjusted from last newsletter

Respectfully submitted,  
 Noel Butzke, Treasurer

	June Actual	YTD Actual	2004 BUDGET
<b>Beginning Balance</b>	<b>7045.72</b>	<b>6528.15</b>	<b>6528.15</b>
<b>INCOME</b>			
Dues	302.00	2,938.00	6,000
<b>TOTAL INCOME</b>	<b>302.00</b>	<b>2938.00</b>	<b>6,000</b>
<b>EXPENSE</b>			
Workshops/Programs	100.00	3,352.55	3,500.00
Income	0.00	-1,870.00	
Newsletter	74.88	360.50	1,000.00
Equipment	0.00	0.00	100.00
WEB	70.00	170.00	430.00
Meeting Exp	0.00	0.00	140.00
Administrative	62.36	202.17	500.00
Library Exp	68.67	279.10	650.00
Toys-Tots	0.00	0.00	200.00
<b>TOTAL EXPENSES</b>	<b>375.91</b>	<b>2494.32</b>	<b>6,520</b>
<b>Ending Balance</b>	<b>6971.81</b>	<b>6971.83</b>	<b>6008.15</b>

## **TWA Meeting Minutes Tuesday, June 15, 2004**

Hal Liberty, President, opened the meeting at 7:30 at the Woodworking Shop on Capital Blvd. and introduced several visitors.

Fred Ford announced the nominees to replace Kay Baker and Noel Butzke who are ending their three year terms on the Board. The nominees are Rich Cornell and Bill Anderson, who has agreed to fill the secretary position. There were no new nominations from the floor.

Rick Cornell passed out renewal cards and a survey inquiring how members would like to use club funds.

Bruce Wrenn announced that he is doing a cyclone dust collection workshop August 21<sup>st</sup>. Contact him for further information.

Hal Liberty reported on the progress of the project for the Audubon Society. Six of the 8 x 8 10 ft. posts were planted last Saturday. There are 2 vertical posts that are 8 x 8 x 12 ft. and will have 12 ft. 4 x 8s attached. Help is needed for lifting. The benches are being made of lpe. Contact Hal if you can help.

Merl Baldwin announced that George Kessell is selling out his shop. Give George a call if you are interested.

Bruce Wrenn presented the program on getting the most out of your table saw giving his usual array of vast information.

The door prize was a 3 foot piece of T track donated by Tom Ferone, manager of Woodcraft.

There were approximately 75 people present and the meeting was adjourned at 9:00.

Submitted by Kay Baker, Secretary

### **ATTENTION CLUB MEMBERS!**

The Executive Board is looking for a volunteer this year to help review our financial transactions prior to the new treasurer taking office. If any of you have bookkeeping or accounting experience and would like to help our, please contact Bob Gabor at 919-542-5951 or via email at: [rjgwood@mindspring.com](mailto:rjgwood@mindspring.com)

## **President's Corner**

Again, we have had another fine presentation by a TWA member. Even though I had heard some of this information on table saws, I find that hearing it again helps me retain the information.

Volunteers from the Audubon Society and myself have made great headway on the arbors. I have attached a picture of one of the four. I will build a prototype of one of the seats with cheap wood and then after I have it approved, I will get the good wood and build four seats. I will call for volunteers for the seat building when I start them.

-Hal



Audubon Society Arbor

### **Nominations for Board Members**

Report form the Nominating Committee (Dave Mackie, Noel Butzke and Fred Ford)

At the last meeting, nominations were presented by the Nominating Committee and nominations were also solicited from the floor.

Nominations for board membership are now Bill Anderson and Rick Cornell. They are nominated to replace Kay Backer and Noel Butzke, who are retiring.

At the July meeting you will meet the nominees and have an opportunity to ask any question you might have. Elections will be held at the August general meeting.

Submitted by Fred Ford

## Notes from June Meeting: Sources

- Bruce Wrenn

### Supplies

HDPE: Wear strip for tobacco harvester. Agri Supply, Garner. (Item #24901-\$6.99) used to make miter slot runners for jigs. 3/8"x1"x10'.

Table Saw Inserts: 1/2" MDF Lowes, Home Depot or Capital City Lumber (1 sheet @ 49" x 97" yields 84 inserts.)

Socket Set Screws: Used to adjust height of inserts. 10-24 x3/8" Wilders Inc – Raleigh, \$10/box of 100.

Spring Pings: Used to retain inserts. 3/32" x 5/8", item P-8 \$3.00/100. Reid Tool Supply, 1-800-253-0421. [www.reidtool.com](http://www.reidtool.com)

Drill & Tap Set: Vermont American – Black Max Tap & Drill Combo. 10-24 Tap & #25 Drill Item #21683, Lowes about \$4.00

Dial Indicator: Harbor Freight, Item #00623 #13.99, usually on sale \$6.99. Used to align miter gauge and rip fence.

HDPE for Inserts: 1/2" x 4" x 48" UHMW sheet. Peachtree Woodworking Supply, Inc. 1-888-512-9069 or [www.PTREEUSA.com](http://www.PTREEUSA.com). Call for pricing and shipping information.

### Books:

Care and Repair of Shop Machines – John White, Taunton Press. \$19.95. Shows how to tune table saw.

25 Essential Projects for Your Workshop – Popular Woodworking Magazine \$22.99

Table Saw Magic – Jim Tolpin. Popular Woodworking Books - \$24.99

Note: You may want to share a sheet of 1/2" MDF with a friend as it yields 84 inserts. The socket set screws come in boxes of 100, you need a maximum of six for an insert. The roll pins can be bought individually or in lots of 100. You need one per insert. Share with a friend.

If you share a shop with a car, then you ought to check out The Little Shop – Mark II in 25 Essential Projects for Your Workshop as it is a combination table saw and cabinets on rollers.

## Meeting Manners

-Bruce Wrenn

I have hesitated to write this but now feel I must. Paul and the staff graciously host our meetings at The Woodworking Shop – thank you, Paul. Prior to our meetings they have to move the power tools from the meeting area. Then we (TWA) need to get out the chairs & tables for our meeting. The librarian needs two tables and a chair. She needs books and tapes from the cabinet in the back and time to set them up. After the meeting the chairs, books, tapes and tables need to be returned to their proper place. All trash, especially drink cans and cups need to be thrown away. Please don't set a cup or drink on either the machines or sales displays. After we leave, Paul and his staff will return the machines to their places, but they can't until we clean up! If you want to visit with another, step out on the front walk, after cleaning up of course. Let's be better stewards of the privilege of meeting at The Woodworking Shop.

## Wood Working Tips From the Web!

Editor's Note: This article is not an original piece but was found on the internet at: <http://www.woodworkingtips.com/etips/etip030228ws.html>

### Circular Saw Crosscut Jig

I often had trouble making square cuts in "two-by" stock with a circular saw. So I solved this problem by making a simple guide jig. As you can see in the upper drawing, the jig is just a wooden box that's notched to fit a specific size of stock. Two guide pieces are screwed to the top of the box at right angles to the "two by" stock. And the guides are spaced to match the width of the shoe on the saw. To use the jig, just slide the workpiece into place and position it for the cut (lower drawing). Then hold it steady and the guides will do the rest.

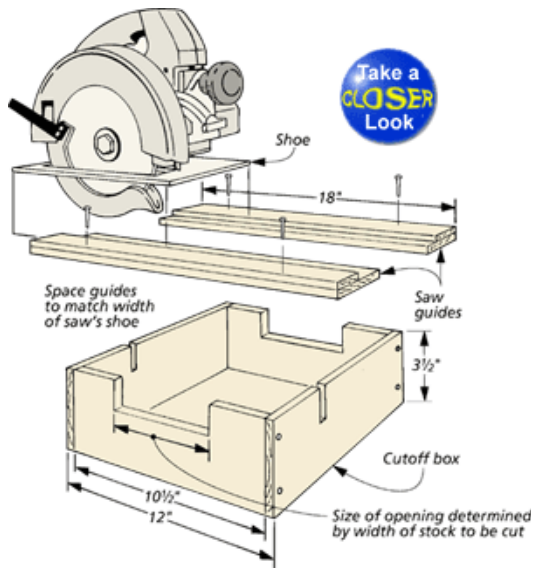

Good Woodworking,  
Ted Raife Online Editor, *Woodsmith*

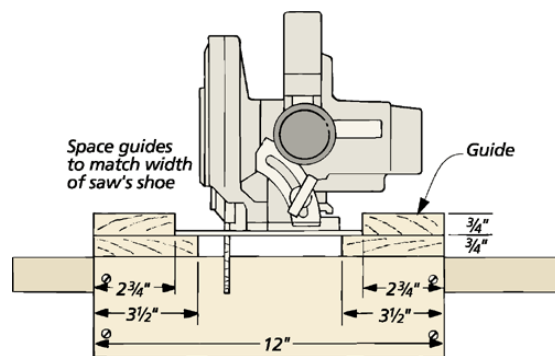

### Candid Shots from Our June Meeting



## Midwest Tool Collector's Meeting

The annual joint Midwest Tool Collectors Association (MWTCA) and Early American Industry Association (EAIA) meeting will be held at Ed Hobbs' Farm in Raleigh on Saturday July 24, 2004. As in the past, all TWA members that are not MWTCA and/or EAIA members are invited to attend. Over 240 people attended in 2003.

For those of you who may not be aware, MWTCA is for more than just tool collectors. M-WTCA offers everyone who is interested in antique/traditional hand tools an opportunity to learn more about tools, to buy and sell tools and to interact with others that share this interest.

This year's meeting will begin officially at 8 AM (some early birds will get here at daybreak) with tool buying/selling/trading. We will have about 45 dealer tables set up under a tent as well as another 30 or so people tailgating under the shade trees. You will be able to find a wide variety of antique and traditional tools for sale at reasonable prices. Coffee, donuts, water and soft drinks will be served.

The program at 10 AM will be on wooden boat building by the wooden boat class from Cape Fear Community College in Wilmington. They will bring a couple of skiffs they have under construction and demonstrate steam bending and other boat building skills.

Following the program, there will be a good old catered pig picken with all the fixings.

After lunch, there will be a tool auction open to everyone. There is no buyer's premium. This auction typically has a wide selection of collectable as well as "user grade" antique and traditional tools.

Our policy for guests is to allow them to attend for \$15 for one time to see what goes on and to find out about the benefits of belonging to MWTCA and/or EAIA. If you have attended as a guest before and wish to attend again as a guest you are welcome, however, you will be charged the full meeting cost of \$20.

To ensure we have adequate food, beverages and facilities, we are again requiring pre-registration. Please complete the form below and send it in so it is received by July 14. To get to the farm, take Exit 299 (Lake Wheeler Rd) off of I-40/440 in Raleigh. Go out of town. You will go about 2 miles and cross over Tryon Rd. Continue on Lake Wheeler Rd for ¾ mile then turn left on Inwood Rd. Go ¾ mile and farm is on left. Please park on the road. Ed Hobbs, 4417 Inwood Rd, Raleigh, NC 27603-3315 Tele 828-2754 E-mail [hobbsed@portbridge.com](mailto:hobbsed@portbridge.com)

-----  
Return this form with your check made out to MWTCA Area Q to the address above **by July 14. If this is your first time attending, enclose \$15 for each person. If you have been here before, please enclose \$20 for each person.**

Name of TWA member(s) \_\_\_\_\_

TOTAL ENCLOSED: \_\_\_\_\_

## TWA Sponsors

Ashcroft Saws and Tools 876-3223  
3216-G Wellington Ct, Raleigh, NC  
25% off list on blades and 10% off on sharpening

Capitol City Lumber Co. 832-6492  
4216 Beryl Road, Raleigh, NC 1-800-244-6492  
Special prices to TWA members  
<http://www.capitolcitylumber.com/>

Carolina Builders 828-7471  
3000 Yonkers Rd  
Hwy. 64 & Old US 1

Klingspor's Woodworking Shop  
(919) 876-0707  
3141 Capital Blvd. (.9 mile N of Beltline exit 11)  
(10% discount excluding lumber and power tools)  
[www.woodworkingshop.com](http://www.woodworkingshop.com)

Raleigh Hardwood Center 231-6620  
4213 Poole Rd, exit 15 off 440 Raleigh, NC  
(10% discount all non-sale items)  
[www.hardwoodgroup.com](http://www.hardwoodgroup.com)

Raleigh Saw 832-2248  
806 McCulloch Street, Raleigh, NC  
(10% discounts on all new products)

Tarheel Wood Treating Co. 467-9176  
Highway 54, Morrisville, NC  
(Contractors prices on all wood products)  
Show TWA card before order is written

Yarnell-Hoffer Hardware 942-3500  
145 Rams Plaza, Chapel Hill, NC  
[www.doitbest.com/yh](http://www.doitbest.com/yh)  
10% discount except power tools and sale items

Tarheel Wood Treating Co. 467-9176  
Highway 54, Morrisville, NC  
(Contractors prices on all wood products)  
Show TWA card before order is written

The Hardwood Store 1-888-445-7335  
Gibsonville, NC  
Discount: 10 cents per board foot  
[www.hardwoodstore.com](http://www.hardwoodstore.com)

Woodworker's Supply of NC  
1125 Jay Lane, Graham, NC  
(Wholesale prices)  
store (336) 578-0500  
mail order 1-800-645-9292  
[www.woodworker.com](http://www.woodworker.com)

Professional Tool Manufacturing  
[www.drilldoctor.com](http://www.drilldoctor.com)  
25% Discount for online purchase of any Drill Doctor. Must use coupon code: TWAi  
Contact [wms@protoolmfg.com](mailto:wms@protoolmfg.com) with any questions.

Guy C. Lee Building Materials 362-1444  
900 N. Salem St., Apex, NC

The following companies do not provide discounts to Members but support TWA and our programs in other ways:

Home Depot DeWalt Tools

\* \* \* \*

*Members, sponsors and potential sponsors are invited to contact Ed Karolak with their ideas, questions, or concerns at [Ekarolak@aol.com](mailto:Ekarolak@aol.com) or call at 919-383-4233*

### **\$ CLASSIFIED ADS \$**

Classified ads are free to all current members. If you would like something listed, please send a note to the editor at [TriangleWoodworkers@yahoo.com](mailto:TriangleWoodworkers@yahoo.com)

**Lumber For Sale:** Furniture Grade: White & Red Oak #1 Common \$1.00 B.F. Clear \$2.00 to \$2.50 B.F. 3' - 16' long up to 12" wide. Poplar #1 Common 70 cents B.F. Clear \$1.50 B.F. Also colorful Hickory, Soft Maple & Walnut. A little left of Planed & Kiln dried. Quantity discount. Arlin Scott 967-6017 prefer you call evenings. Chapel Hill

**For Sale:** Used Craftsman 16 gallon convertible wet/dry shop vac. \$60. Used 12 inch, 3 wheel, variable speed Central Machinery benchtop bandsaw with extra unused blade. \$40. Used Duraclean Kerosene heater \$40. (Will also include extra kerosene I have on hand—about 3 gal.). Used Craftsman 4 1/8" Benchtop Jointer/Planer \$75. Contact Rick Cornell 919-270-0650 or [r\\_corne@yahoo.com](mailto:r_corne@yahoo.com).

**For Sale:** 18" Grizzly Band Saw, 220V, 2 HP, \$300.00, Dewalt 12" Compound Miter Saw (DW708) and Dewalt Miter Saw Stand (DW723), \$600.00, Craftsman 10" Contractor Series Table Saw, \$100.00, Porter Cable Finish Nailer (F205), \$75.00, Craftsman 1/2 HP Router, \$25.00, Grizzly 2 HP Dust Collector, \$200.00, Clamps, Large Assortment, \$75.00, Call at 557-5035 or email [tylerwaters@hotmail.com](mailto:tylerwaters@hotmail.com)

**For Sale:** Performax ShopPro 25 Sander, like new( less than 10 hrs. use): mobile caster base, \$1000.0 Phone 919-796-4919

# TWA

## Membership Application

Complete and mail to:

Triangle Woodworkers Association  
P.O. Box 4206  
Cary, North Carolina 27519-4206

Name: \_\_\_\_\_

Address: \_\_\_\_\_

City: \_\_\_\_\_ State: \_\_\_\_\_ Zip: \_\_\_\_\_

Phone: \_\_\_\_\_ E-mail: \_\_\_\_\_

Spouse's name, if joining (fee is \$1.00): \_\_\_\_\_

Skill level:      Beginner [ ]    Intermediate [ ]    Advanced [ ]    Professional [ ]

**New member- email newsletter \$30.00 [ ]**

**New Member – hard copy newsletter \$35.00 [ ]**

**Renewal – email newsletter    \$25.00 [ ]**

**Renewal – hard copy newsletter    \$30.00 [ ]**

**Check #** \_\_\_\_\_

**Cash** Amount \_\_\_\_\_ (Do not send cash through mail!)

**Privacy Opt-Outs:** Please Do NOT Publish My [ ] Phone Number [ ] Email Address on Membership lists. (Note: This means your phone and email information will be used only for club correspondence by club officers and committee chairman)

**MEMBERSHIP EXPIRED?** Check the mailing label, for the expiration date of your membership. If it says EXPIRED, please contact our membership coordinator to renew. You may receive several newsletters past your expiration date and then no more. If you have a question about your membership, please contact Rick Cornell (919-319-9980).

Triangle Woodworkers Association  
P.O. Box 4206  
Cary, North Carolina 27519-4206