

TWA News

July 2007

Volume 24

Issue 7

Next Meeting:

July 17th, 2007 7:30 PM
The Woodworking Shop
3141 Capital Boulevard
Raleigh, NC

Several members meet 6:00 pm, at Buffalo Brothers
Pizza & Wings for dinner prior to the meeting.

July Meeting – Build a Bandsaw Box

Hosted by Kay Baker, Tom Ferone, a TWA member and manager of The Woodcraft Store will discuss design considerations and techniques for building and finishing various styles of band saw boxes ranging from traditional to freeform. Tom has taught several classes at his store over the year's on this very subject matter. He will follow this presentation with a 2-day workshop on Saturday and Sunday (7/21 & 7/22) where participants will have the opportunity to design and build a band saw box in either the traditional or freeform style. His workshop will cover material selection, design considerations, stock preparation, layout, cutting, and assembly with a closing discussion on finishing techniques. Space is limited to 10 participants, and as always, your payment is your reservation.

August Meeting – Woodworker Safety

Jim Duxbury will present a program on hearing, eye and respiratory safety for woodworkers. He will discuss the various options for equipment and their price ranges. For example, are you aware that ear plugs are more effective ear protection than are earmuffs? And the earplugs are cheap. Jim is a diver, certified in underwater research, a field that led him to invent the Mouthpiece Respirator for woodworkers. He is wood turner and a member of both the Triangle and Piedmont Wood Turners clubs and the current Program Chair for the Piedmont club. The August meeting will be hosted by Cecil Raynor.

September 11th Meeting

We have decided to bring back this once popular event. Now is the time to bring your family for good fun and eats. We hope to have a surprise speaker, which we may announce ahead of time. Reserve this date on your calendar now! Host: Jane Main

Club Membership Dues Payable this Month

Last year we converted everyone to have a common expiration date of July 31st for their club membership dues. Well, here we are in July! If you have not already done so, please renew now!

A word of thanks to those 42 who have already done so. Notices were sent out last month so you should already have all that is necessary. But just in case, a renewal form is contained in this newsletter for your convenience. Please complete the form in its entirety as I will use it to confirm the information in our membership data base.

I did receive some feed back regarding the instructions in the notices. Please be aware these steps are not to make it more difficult to pay your dues. We have no means to issue proper receipts for cash payments, so your cancelled will serve as your receipt. All other club officers have their hands full, without trying to act as a middleman between you and the membership committee. Therefore all dues should either be mailed to the club post office box, or personally given to me.

Please be aware that any memberships not paid up by the end of the month will result in interruption of your receipt of the club newsletter!

Don't delay! Take a moment and send in your dues today!

Rick Cornell, Membership Committee Chairman



WWW.LIBERPRINTS.COM

SHOW YOUR COLORS – WEAR A TWA TEE SHIRT

They are available in all sizes – XL, L, Med,
Small (for ladies and kids) and even a few 2XL.

Great value at \$10 each

Contact Mike Reddyhoff at 676-9180 (miker@nc.rr.com)

About the Triangle Woodworkers Association

The Triangle Woodworkers Association (TWA) is a nonprofit educational corporation. The TWA is dedicated to teaching woodworking techniques through seminars, classes, and workshops; participants are required to sign waivers absolving liability for TWA or its designated representatives. The TWA promotes woodworking education and community interest in woodworking and in general sharing a love for wood.

Club Officers and Committee Chairmen

Executive Board

President: Fred Ford, (919) 469-9575 or fredford@nc.rr.com
Vice President: Cecil Raynor, (919) 870-0508 or raynorc@bellsouth.net
Secretary: Bill Anderson, (919) 932-6050 willardanderson@bellsouth.net
Treasurer: Pete Kasper pkasper@nc.rr.com
Members at Large: Rick Cornell, {vacant}, Kay Baker

Committee Chairman

Program: Cecil Raynor, (919) 870-0508 or raynorc@bellsouth.net
Nominating: Fred Ford, 919-469-9575 or fwford@bellsouth.net
Toys for Tots: Fred Ford, 919-469-9575
Newsletter: Rick Cornell, 919-270-0650 or trianglewoodworkers@yahoo.com
Library: Kay Baker, 919-696-8504 kdbakerkdb@yahoo.com
Publicity: Charlie & Jane Main, (919) 787-4446
Facilities: Chet Nedwidek,
Raffle: {vacant}
Sponsor: Bill Anderson, (919) 932-6050 willardanderson@bellsouth.net
Hospitality: Kay Baker, 919- 696-8504
Internet: Jim Kroeger, (919) 362-5741
Photographer: Ron Heidenreich, 919-848-1134
Membership: Rick Cornell - 919-270-0650 or Trianglewoodworkers@yahoo.com
Audiovisual: Tom Revelle, 919-387-8286

TWA News is published monthly by the TWA and is mailed to members, sponsors, and associates. If you are interested in contributing articles, please send to:

Triangle Woodworkers Association
P.O. Box 4206
Cary, North Carolina 27519-4206
or trianglewoodworkers@yahoo.com

Deadline for submitting articles and classified ads to the next newsletter is end of day:

July 31st, 2007

By the Numbers

Treasurer's Report

Beginning Bank Balance:	\$2,949.31
Income:	\$16.00
Expense:	<u>\$164.66</u>
Ending Bank Balance:	\$2,800.65

Respectfully submitted,
Pete Kasper, Treasurer

Membership

Total Members:	189
New Members:	0
Dropped:	0
Renewals:	42

Make a Molding Plane Class

Bill Anderson, a TWA member is offering a class through Edwards Mountain Woodworks. The class, Make a Traditional Molding Plane will be held August 18-19, 9 am-5 pm. This is a workshop to make a traditional style molding plane using a combination of modern and traditional methods. The workshop will have an in-depth look at the anatomy of a molding plane and the tools and jigs required to layout and shape a plane.

On the first day we will use a combination of scratchstock and other molding planes to shape the sole of the plane and chisels and floats to fit the wedges. On the second day we will shape and temper the cutter, then we will learn the techniques of cutting molding with a handplane. Call or email for cost and other details. 919.932.6050, willardanderson@bellsouth.net

Newsletter Seem Different?

This month's newsletter may seem a bit different – either missing standard articles or containing duplicate information from the prior newsletter. This is a result of a fact of life being even a newsletter editor takes a vacation! I will be on vacation during the time frame in which you normally receive your newsletter.

Rather than have it arrive too late, I have asked all contributions to be in by the 22nd, rather than the normal end of the month! Some folks have other things going on, or are just creatures of habit, and were unable to provide the information in time.

We will have the full contingent of contributions again next month!

June 19th Meeting Minutes

Attendance: 57

Visitors:

1. **Jane Reddyhoff**, England
2. **Tom Purdue**

Business:

1. **Fred Ford:** The Toys for Tots program needs two additional coordinators to help. Mike Reddyhoff has volunteered. This work will require about a total of 16 hours commitment until the end of the year. Please call Fred.
2. **Rick Cornell:** Dues are due by the end of July. Please pay Rick by check in person or by mail. The check provides a paper trail for audit. Please correct any changes in your contact info.
3. **Ed Hobbs:** The MWTCA meeting will be at Ed's farm (off Lake Wheeler Road, Raleigh) on July 28. There will be an auction and a pig pickin'. Pre-registration is required for the meal. A form will be in the current newsletter.
4. **Bruce Wren:** TWA will resume its social program at the Cary Senior Center, Bond Park on 9/11/07 from 6-10 pm. Bring family and friends. \$10 per person. Need a reservation by Sept. 1. This will be a second Tuesday meeting. The program will consist of a show and tell.
5. **Fred Ford:** The nominating committee will present candidates in July and the election is in August. There are 3 openings for the TWA Board. Mike Reddyhoff has volunteered to be secretary for 1 year. Bob Whitney and Mike Rezoﬀ are also candidates. Please volunteer.
6. **Jim Kroeger:** Dale Morrison (jdm2@us.ibm.com) has 4 standing walnut trees that need to come down. These are 43-63 inches in diameter. Please contact him if you are interested.
7. **Cecil Raynor:** TWA needs a Program Committee Chairperson for the next election cycles. Cecil would like that person to "apprentice" with him for this year to see how the job is done.
8. **Tom Ferone:** Denzil Ames will not be able to give the July program. Tom will conduct

this in his shop. He estimates that the bandsaw box workshop will cost about \$45 for fees and materials. Workshop size is limited to 10 participants. Please mail or give your checks to Kay Baker.

Program

Fred Ford introduced a number of members who talked for a few minutes each about their current projects or jigs.

1. **Terry Brown.** Showed 8 different jigs, ranging from a fingerboard for the table saw to steady rest modifications for the lathe, to a pair of center finders.
2. **Bob Gabor.** Three cut-off sleds for the tablesaw: a standard sled, a box-joint sled, and a miter sled.
3. **Cecil Raynor.** Router base for cutting centered mortises.
4. **Pete Kaspar.** Jigs and techniques for cutting raised panels on the tablesaw. Pete had a handout on this subject as well.
5. **Bill Anderson.** Sharpening jigs for 3 types of spokeshaves, two jigs for scraper sharpening and a plane blade jig for setting bevel angles.
6. **Mike Payst.** A benchtop workbench with a vise made from two veneer press screws.
7. **Bruce Wren.** Jigs for making tablesaw push sticks with replaceable bottoms, a jig for making a zero clearance insert for the tablesaw, a circle cutter jig for the router.
8. **Hal Brown.** Miter sled with toggle clamps for picture frames, and a biscuit joiner jig for splines for mitered corners.

Respectfully submitted,
Bill Anderson, Secretary

From The Presidents Corner

Nominations were made at the last meeting for board members to be elected this August. You will have an opportunity to meet the candidates in July. Nominated were Mike Reddyhoff, Mike Resar, and Bob Whitney. I would like to thank them all for stepping up to the job.

After the election is complete the board will appoint members to the executive positions. Mike Reddyhoff has expressed willingness to assume the duties of secretary from Bill Anderson who is retiring. Bill has expressed interest in rejoining the board after a year and reassuming the secretary position. At that time Mike Reddyhoff has expressed interest in being president. That still leaves adequate openings for anyone interested in joining the board.

Mike Resar and Bob Whitney will begin as at-large members.

Bruce Wrenn and I both mentioned the September 11 general meeting. This is an attempt to start having an annual social meeting. It is a general meeting, but with a topic of broad interest to entertain woodworker, spouses and other invited guest. I hope that all members will make an effort to attend.

Submitted by Fred Ford

Toys for Tots Kickoff

We have an excellent record of accomplishment to match this year. In past years, fifty to seventy members have produced thousand of toys for needy children. As we did last year we will be pushing for quality toys and we will let the numbers fall where they will.

Mike Reddyhoff will be coordinating the sign up and manning the workshops. He will pass out the sign up sheet for the first time at the July general meeting. Please sign up! If you can not make the meeting you can have your name added by calling Mike or I. Mike is the prime contact and his number is 676-9180. Mike will be out of the country for a few weeks so if you can not reach him please call me at 469-9575.

Many of us are looking forward to many fun and productive workshops. New members please step up.

Submitter by Fred Ford

Measuring Diagonals Easily

The last step to assembling a case is to make sure it's square. And the quickest way to do this is to measure diagonally from corner to corner. (If it's square these measurements will be the same. If not, you'll need to make some adjustments.) Using a tape measure is an easy way to check for square. The problem is that keeping the end of the tape on the corners can be difficult. But with a quick modification to the hook of the tape you can solve this problem.

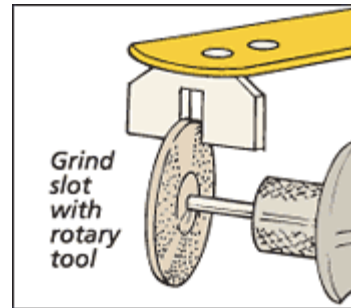

To do this, simply cut a small slot on the hook with a rotary tool (or hack saw), see the drawing above right.

The slot slips over the point of the corner of the project, see the drawing and detail at right.

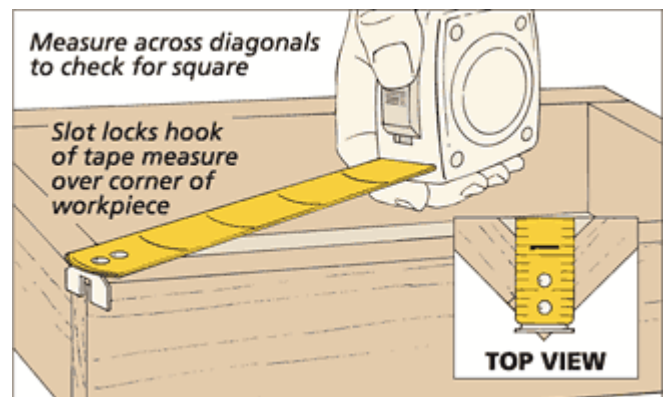

The slot holds the tape in place for those large projects where an extra set of hands would be a big help. And it doesn't effect the tape measure's accuracy when I use it for other projects.

Good Woodworking,
Ted Raife, Online Editor, *Woodsmith*



TWA 2008 Renewal Form

Annual MWTCA Meeting

The annual Midwest Tool Collectors Association (MWTCA) meeting will be held at Ed Hobbs' Farm in Raleigh on Saturday July 28 2007. As in the past, all TWA members that are not MWTCA are invited to attend. Over 275 people attended in 2006.

For those of you who may not be aware, MWTCA is for more than just tool collectors. M-WTCA offers everyone who is interested in antique/traditional hand tools an opportunity to learn more about tools, to buy and sell tools and to interact with others that share this interest.

This year's meeting will begin officially, rain or shine, at 8 AM (some early birds will get here at daybreak) with tool buying/selling/trading. We will have about 45 dealer tables set up under a tent and an equal number of people tailgating under the shade trees. You will be able to find a wide variety of antique and traditional tools for sale at reasonable prices. Coffee, donuts, water and soft drinks will be served in addition to lunch.

A program of interest will be held beginning at 10 AM. After the program, there will be a good old catered pig picken with all the fixings.

When lunch is over, there will be a tool auction open to everyone. We have a collection of about 120 good tools (mostly Stanley planes) There is no buyer's premium. A list can be obtained via e-mail by letting me know.

Our policy for guests is to allow them to attend for \$15 for one time to see what goes on and to find out about the benefits of belonging to MWTCA. If you have attended as a guest before and wish to attend again as a guest you are welcome, however, you will be charged the full meeting cost of \$20.

Also, please note that beginning this year there will be a \$5.00 late registration fee added for anyone that has not pre-registered.

To ensure we have adequate food, beverages and facilities, we are again requiring pre-registration. Please complete the form below and send it in so it is received by July 14. To get to the farm, take Exit 299 (Lake Wheeler Rd) off of I-40/440 in Raleigh. Go out of town. You will go about 2 miles and cross over Tryon Rd. Continue on Lake Wheeler Rd for ¾ mile then turn left on Inwood Rd. Go ¾ mile and farm is on left. Please park on the road. Ed Hobbs, 4417 Inwood Rd, Raleigh, NC 27603-3315 Tele 828-2754 E-mail hobbsed@portbridge.com

Return this form with your check made out to MWTCA Area Q to the address above **by July 14. If this is your first time attending, enclose \$15 for each person. If you have been here before, please enclose \$20 for each person.**

Name of TWA member(s)

TOTAL ENCLOSED: _____

Email Notice - \$30
Paper Copy: \$35
Include Spouse Add \$1
Spouse's Name: _____

Check Amount _____

Check Number: _____

Mail to:

**Triangle Woodworkers Association
PO Box 4206
Cary, NC 27519**

Or bring check to meeting and give to Rick Cornell.

Remember - NO CASH PAYMENTS!

Please PRINT CLEARLY and complete the following information to allow me to verify your records.

Name : _____

Address: _____

City: _____

State: _____ Zip: _____

Contact Phone Number: _____

Contact email address: _____

(Required if electing Email Notice)

Privacy Opt-Outs: Please Do NOT Publish My

[] Phone Number

[] Email Address on Membership lists.

(Note: This means your phone and email information will be used only for club correspondence by club officers and committee chairman.)

Club Candids

Photos by Ron Heidenreich

Terry , Mike, Bruce, Bill, Hal, Bob and Pete sharing some of their "tricks of the trade"! Yahoo is discontinuing their picture sharing service. Until I find a replacement, this will have to do! The good news is that they are offering replacement options, but I need to see which ones will work best!



TWA Sponsors

Ashcroft Saws and Tools 876-3223 3216-G Wellington Ct, Raleigh, NC 25% off list on blades and 10% off on sharpening	Wurth Wood Group 231-6620 4213 Poole Rd, exit 15 off 440 Raleigh, NC (10% discount all non-sale items) http://wurthwoodgroup.com
Capitol City Lumber Co. 832-6492 4216 Beryl Road, Raleigh, NC 1-800-244-6492 Special prices to TWA members http://www.capitolcitylumber.com/	Raleigh Saw 832-2248 5805 C Departure, Raleigh, NC 27616 (10% discounts on all new products)
The Hardwood Store 1-888-445-7335 Gibsonville, NC Discount: 10 cents per board foot www.hardwoodstore.com	Stock Building Company 828-7471 3000 Yonkers Rd Hwy. 64 & Old US 1
Guy C. Lee Building Materials 362-1444 900 N. Salem St., Apex, NC	Tarheel Wood Treating Co. 467-9176 Highway 54, Morrisville, NC (Contractors prices on all wood products) Show TWA card before order is written
Klingspor's Woodworking Shop (919) 876-0707 3141 Capital Blvd. (.9 mile N of Beltline exit 11) (10% discount excluding lumber and power tools) www.woodworkingshop.com	Woodcraft 6582 Glenwood Ave Raleigh, NC 27612 Phone: 919-781-1911 http://www.woodcraft.com/stores/store.aspx?id=532 Supplier of monthly raffle gift certificates
Nice Figures Studio and Lumber Sales 1413 New Hope Trace Chapel Hill, NC 27516 Phone: 919-923-1433 information@nicefigures.com contact: Paula Labelle 10% discount, and contribute to the raffle	Woodworker's Supply of NC 1125 Jay Lane, Graham, NC store (336) 578-0500 mail order 1-800-645-9292 www.woodworker.com
East Wake Hardwoods & Gallery 113A West Gannon Avenue Zebulon, NC 27597 Phone:(919)269-9455, Fax:(919)269-7078. http://eastwakehardwoods.com/ 10% Discount to club members	Yarnell-Hoffer Hardware 942-3500 145 Rams Plaza, Chapel Hill, NC www.doitbest.com/yh 10% discount except power tools and sale items

Classified Ads

Classified ads are free to all current members. Ads will run for two issues. If you would like something listed, please send a note to the editor at: TriangleWoodworkers@yahoo.com

Wanted: Borrow an Adze to make one Windsor chair seat. ; Please call Fred Ford if you can help 469-9575.

For Sale: 10" Sears Craftsman Table Saw, Used little. Includes fence, blade, mitre gauge and collection bag. \$100. Contact Frank Mansfield. 919-828-4721.

For Sale: Robland X31 Combination Machine (tablesaw, planer, joiner, shaper, mortiser). Excellent condition, 6 years old. \$3500. List price for a new X31 would be ~\$6k. Review article on the X31 at <http://www.woodcentral.com/bparticles/x31.shtml> . Call 919 846-1260 or email: roger_sanwald@ncsu.edu

Interested in antique/traditional woodworking tools? To find out about Mid-West Tool Collectors Association, contact Ed Hobbs at 828-2754 or hobbsed@portbridge.com (99/99)

In This Issue

<i>July Meeting – Build a Bandsaw Box.....</i>	<i>1</i>
<i>August Meeting – Woodworker Safety</i>	<i>1</i>
<i>September 11th Meeting.....</i>	<i>1</i>
<i>Club Membership Dues Payable this Month .</i>	<i>1</i>
<i>Club Officers and Committee Chairmen.....</i>	<i>2</i>
<i>By the Numbers.....</i>	<i>2</i>
<i>Make a Molding Plane Class</i>	<i>2</i>
<i>Newsletter Seem Different?</i>	<i>2</i>
<i>June 19th Meeting Minutes</i>	<i>3</i>
<i>From The Presidents Corner.....</i>	<i>4</i>
<i>Toys for Tots Kickoff</i>	<i>4</i>
<i>Measuring Diagonals Easily.....</i>	<i>4</i>
<i>Annual MWTCA Meeting.....</i>	<i>5</i>
<i>TWA 2008 Renewal Form</i>	<i>5</i>
<i>Club Candidats</i>	<i>6</i>
<i>TWA Sponsors</i>	<i>7</i>
<i>Classified Ads</i>	<i>7</i>

***Don't risk missing
club news – renew
today to ensure you
get next month's
newsletter!***

***Triangle Woodworkers Association
PO Box 4206
Cary, NC 27519***

