

\$2.00

# 2016 Rule Book



*Rule Books Compliments of*

**Clay GMC**

470 Main Street, Lincoln, ME

**(207) 794-6191 • (207) 794-6503**

TO PULL DIRECTORS, SECRETARIES AND PRESIDENTS  
OF ALL CHARTERED CLUBS OF MSTTPA:

ALL PAPERWORK MUST BE INTO THE STATE SECRETARY'S  
OFFICE NO LATER THAN 7 DAYS AFTER EVENT HAS RUN.

**OFFICERS 2015**

**PRESIDENT**

**STEVE MADDEN**

PO BOX 59 CARDVILLE, ME 04418  
PHONE: 827-5737

**PETER KERN**

435 PALMYRA ROAD  
ST. ALBANS, ME  
PHONE: 416-9933

**SECRETARY**

**STEPHANIE BALLARD**

435 PALMYRA ROAD  
ST. ALBANS, ME  
PHONE: 592-0368

**TREASURER**

**DANNY IRELAND**

41 COOLIDGE AVENUE  
HAMPDEN, ME 04444  
PHONE: 942-3035

**VICE PRESIDENT**

**BOARD OF DIRECTORS 2015**

**3 YEAR TERM**

**KIM CARTER**

420 CHINA ROAD  
WINSLOW, ME  
PHONE: 660-2181

**MARTY CARMICHAEL**

P.O. BOX 163  
GREENBUSH, ME 04418  
PHONE: 827-2858

**JEFF JOHNSON**

41 WARDS HILL ROAD  
GORHAM, ME 04038  
PHONE: 776-9735

**JOHN STOUGHTON**

71 MCKENNEY ROAD  
CLINTON, ME 04927  
PHONE: 207-649-8900

**DARRELL CASTONGUAY**

999 ALBION ROAD  
WINSLOW, ME  
PHONE: 859-0412

**2 YEAR TERM**

**ELDON PELLETIER - NPPA**

10 RUSH BLVD.  
MILLINOCKET, ME 04462  
PHONE: 723-4990

**RUSSELL BUGBEE**

1636 PARSONS ROAD  
MAPLETON, ME 04757  
PHONE: 764-8424

**JOSH DEVLIN**

PO BOX 174  
CARMEL, ME 04419  
PHONE: 207-848-8300

**2 YEAR TERM**

*(Cont.)*

**JEFF PELLETIER**

415 MORGAN LANE  
MILLINOCKET, ME 04462  
PHONE: 207-447-0734

**PETE MERCIER**

PO BOX 222  
PRINCETON, ME 04668  
PHONE: 796-5119

**1 YEAR TERM**

**WENDELL DUNLAP**

438 SOLON ROAD  
NORTH ANSON, ME 04958  
PHONE: 207-399-0494

**JON DOODY**

79 CHASE HILL ROAD  
WESTBROOK, ME 04092  
PHONE: 797-9596

**JR DOW**

547 MUDGETT ROAD  
CORINTH, ME 04427  
207-852-3287

**STEVE ANDREWS**

124 MADDOX FARM ROAD  
LYMAN, ME 04002  
PHONE: 499-2205

**TODD MICHAUD**

PO BOX 1812  
PRESQUE ISLE, ME 04769  
PHONE: 207-554-8451

# REGISTRATION

ANYONE THAT DOES NOT REGISTER AND PULLS WITHOUT PAYING WILL FORFEIT ANY POINTS AND PRIZE MONEY FOR THAT EVENT AND WILL BE DISQUALIFIED. 2ND OFFENSE WILL BE BANNED FOR 1 YEAR AND 10 DAYS.

2.5 DIESEL CLASS POINTS WINNER FOR THE PAST YEAR IN THE TOP 6 SPOTS WILL BE ALLOWED TO PULL IN THE 2.6 DIESEL CLASS PROVIDING THEY HAVE ALL THE SAFETY EQUIPMENT IN PLACE AND OPERATIONAL. MUST MEET ALL SAFETY REQUIREMENTS.

ALL RULE CHANGES EFFECTIVE FOR 2015 PULLING SEASON, NO RULE CHANGES ACCEPTED FOR THE NEXT 3 YEARS UNLESS 75% OF THE CLASS AGREES IN WRITING AND HAS BROUGHT FORWARD TO THE MSTTPA SECRETARY WHAT RULES THEY WOULD LIKE TO CHANGE. ANY SAFETY ISSUE CAN BE IMPLEMENTED BY THE EXECUTIVE OFFICERS AND/OR THE BOARD OF DIRECTORS AT ANY TIME.

**Changes to rule book are in bold print**

## HONORARY DIRECTORS

FRED LUNT, JR.  
TINKER KIESMAN  
DANA WEBSTER

# INDEX

By Laws of the MSTTPA .....	5
MSTTPA Point Regulations .....	8
MSTTPA Operation of Contest Disciplinary Procedure .....	10
Fire Extinguishers .....	10
Event Procedure and Requirements .....	14
Test Pull and Options.....	15
Pull Offs, Inclement Weather .....	16
Additional Causes for Disqualification, Protest Procedure for All Classes.....	17
Procedure for Lawn & Garden Tractors .....	18
2x4 and 4x4 Vehicle Disqualifications .....	18
4x4 and 2x4 Fuels .....	19
4x4 and 2x4 Pro-Stock & Superstock (Hitch Qualifications).....	20
4x4 Driveshaft Qualifications (Pro-Stock, Superstock, Modified and Semis).....	20
Hub Shields, Street Stock Class.....	21
Super Street Stock Diesel Class.....	22
3.0 Pro-Stock Diesel 4x4 Truck.....	23
4x4 and 2x4 Pro-Stock Class .....	23
4x4 Super Stock Class .....	25
4x4 Modified Class .....	26
Two Wheel Drive Rules, 2x4 Superstock Class Rules .....	26
2x4 Modified.....	27
General Farm Tractor Rules.....	28
Stock Farm Tractor Rules & Regulations.....	28
Super Farm Tractors, Superstock Tractors, Modified .....	30
Pro-Stock Tractors, Pro-Farm Tractors.....	31
Mini Rules General .....	32
Chassis, Engines .....	33
Exhaust Systems, Fuel and Fuel Containers, Kill Switches .....	34
Safety, Seats & Fencers .....	35
Tires, Clutches, Flywheels & Automatics .....	36
Stabilizer Bars, Driveline Shielding, Brakes, Drawbar .....	37
Mini Modified Adding Weights.....	39
SFI, General Rules for Lawn & Garden - Non-Automotive, 4 Cyl, V8 Minis.....	39
Stock Lawn & Garden Tractor Class .....	40
Non-Automotive Engine Powered Tractor Class .....	41
4 Cylinder Mini Modified Tractor Class .....	42
Modified Lawn & Garden Tractor Class .....	44
Semi Truck Rules.....	46
Fifth Wheel, Tires, Vehicle.....	46
Weights or Added Ballast, Chaining of Axles.....	48
Axles Power Train, Turbo.....	49

**BY LAWS OF THE MAINE STATE  
TRUCK & TRACTORS PULLERS ASSOCIATION**

1. THIS ORGANIZATION SHALL BE KNOWN AS "THE MAINE STATE TRUCK AND TRACTOR PULLERS ASSOCIATION."
2. **INTENT:** TO PROMOTE WEIGHT TRANSFER BY MECHANICAL MEANS WITH TRACTORS AND TRUCKS WITHIN THE STATE OF MAINE.
3. **GOALS:**
  - a. TO ESTABLISH UNIFORM RULES AND REGULATIONS OF SAFETY AND RULES FOR PULLING.
  - b. TO ESTABLISH RULES OF SAFETY FOR THE WEIGHT TRANSFER SLEDS.
  - c. TO DEVELOP A SCHEDULE OF PULLS WITHIN THE STATE OF MAINE.
4. THIS ORGANIZATION SHALL OPERATE UNDER ROBERTS RULES OF ORDER.
5. **ORGANIZATION:**
  - a. THERE SHALL BE FOUR OFFICERS: PRESIDENT, VICE PRESIDENT, SECRETARY, AND TREASURER.
  - b. THERE SHALL BE FIFTEEN MEMBERS THAT SHALL ACT AS THE BOARD OF DIRECTORS AND THREE OFFICERS.
  - c. MEMBERSHIP SHALL BE OPEN TO ANY ORGANIZATION, GROUP, OR INDIVIDUALS INTERESTED IN WEIGHT TRANSFER BY MECHANICAL MEANS.
  - d. OFFICERS AND BOARD OF DIRECTORS WILL BECOME AN AUTOMATIC NON-COMPETING MEMBER OF MSTTPA WHEN ELECTED.
6. **TERMS OF OFFICERS AND BOARD OF DIRECTORS:**
  - a. THE PRESIDENT MAY SERVE FOR MORE THAN TWO CONSECUTIVE YEARS.
  - b. VICE-PRESIDENT & SECRETARY-TREASURER. (IF ELIGIBLE), MAY MOVE UP TO THE OFFICE OF THE PRESIDENT.
  - c. IN ORDER TO KEEP CONTINUITY WITHIN THE ORGANIZATION. THE TERMS OF THE BOARD OF DIRECTORS SHALL BE STAGGERED. ONE THIRD OF THE DIRECTORS SHALL BE ELECTED OR REELECTED EACH YEAR.
  - d. PRESIDENT AND VICE PRESIDENT COME FROM THE BOARD OF DIRECTORS AND THE SECRETARY-TREASURER MAY BE NOMINATED AT LARGE.

- e. AN OUTGOING PRESIDENT AND/OR OUTGOING VICE-PRESIDENT CAN FILL THE DIRECTOR VACANCIES FOR A ONE YEAR TERM. TO FILL THE VACANCY CREATED BY THE ELECTION OF A NEW PRESIDENT OR VICE PRESIDENT.
  - f. THE OFFICERS AND BOARD OF DIRECTORS MAY CHANGE, WAIVE, OR CREATE ANY RULE IT DEEMS NECESSARY FOR SAFETY REASONS, AT ANY TIME.
  - g. THE PRESIDENT WILL APPOINT ANY OFFICER OR DIRECTOR TO AUDIT THE TREASURERS BOOKS ONCE A YEAR.
  - h. ANY DIRECTOR THAT CAN'T MAKE A DIRECTORS MEETING, MUST CALL THE SECRETARY TO NOTIFY HER, AND GIVE THEIR PROXY. LIMITED TO ONE MEETING PER YEAR.
  - i. IF A DIRECTOR MISSES TWO UN-EXCUSED DIRECTORS MEETINGS IN ONE YEAR, THE POSITION WILL BE RE-ELECTED FOR THE REMAINDER OF THAT TERM, AT THE ANNUAL MEETING.
7. THE ELECTION OF THE OFFICERS AND BOARD OF DIRECTORS SHALL COINCIDE WITH THE ANNUAL MEETING OF THE MSTTPA. WHICH IS HELD EACH YEAR. (LOCATION TO BE ANNOUNCED.)
  8. IN ORDER THAT NO ONE ORGANIZATION TAKE CONTROL OF THE BOARD OF DIRECTORS, THE DIRECTORS SHALL BE ELECTED OR SELECTED ONE FROM EACH ORGANIZATION SPONSORING THE PULLS AND ONE FROM THE DRIVER'S ASSOCIATION OR SLED OWNERS. (CAN BE VOLUNTEERS)
  9. THIS ORGANIZATION SHALL OPERATE AS A NON-PROFIT ORGANIZATION.
  10. DUES:
    - a. DUES WILL BE ASSESSED ON AN ANNUAL BASIS WILL EXPIRE AT THE ANNUAL MEETING EACH YEAR. PAYABLE TO THE TREASURER OR SECRETARY & USED FOR OPERATIONAL COSTS. MAY BE CHANGED BY THE BOARD OF DIRECTORS DURING THE YEAR IF DEEMED NECESSARY.
    - b. THE SECRETARY WILL ISSUE A MEMBERSHIP CARD AND CURRENT MSTTPA RULE BOOK EACH YEAR TO ALL PAID MEMBERS.
    - c. DUES ASSESSED ON A NON-ORGANIZATION MEMBER INDIVIDUAL SHALL BE \$10.00 EACH YEAR.
    - d. PULLING ORGANIZATIONS AND/OR CLUBS WILL PAY AN ANNUAL \$125.00 CHARTER FEE. TO BE ELIGIBLE TO HAVE A MSTTPA CHAMPIONSHIP SERIES POINTS PULL, THIS MUST BE PAID BY APRIL 1ST EACH YEAR. IT IS SUGGESTED THAT EACH PROMOTER GET AN ENTRY FEE OF AT LEAST \$10.00 PER ENTRY. GROUPS THAT ARE NOT PULLING ORGANIZATIONS WILL BE CONSIDERED AN INDIVIDUAL. (EXAMPLE: A FAIR)

- e. A NEW CLUB WISHING TO JOIN MSTTPA MUST BE APPROVED BY THE BOARD OF DIRECTORS AND OFFICERS USING THE BYLAWS OF MSTTPA GUIDELINES.
  - f. ANY VEHICLE THAT PULLS AT A MSTTPA SANCTIONED EVENT WILL PAY AN ANNUAL REGISTRATION FEE. EACH COMPETITOR WILL PAY AN INSURANCE FEE AT EACH EVENT ATTENDED. THE INSURANCE FEE WILL BE CHARGED PER DRIVER. THERE WILL BE 1 VOTE ALLOTTED PER REGISTERED VEHICLE AT THE ANNUAL GENERAL MEMBERSHIP MEETING.
  - g. REINSTATE A ONE TIME PULLER INSURANCE FEE OF \$20.00 PER VEHICLE PER EVENT FOR ALL MSTTPA CLASSES EXCEPT LAWN AND GARDEN TRACTORS. THE FEE MUST BE COLLECTED AT ALL MSTTPA INSURED PULLS (INCLUDING FRYEBURG), AND CANNOT BE MODIFIED. ANY PORTION OF THE FEE CAN BE PAID BY THE PROMOTER, PROVIDED \$10.00 IS COLLECTED BY MSTTPA FOR EACH ONE-TIME PULLING VEHICLE AT THE EVENT.
11. THESE BY-LAWS MAY BE AMENDED BY THIS ORGANIZATION AT ANY ANNUAL MEETING.
  12. ALL RULE CHANGES MUST BE SUBMITTED TO THE SECRETARY OF MAINE STATE TRUCK AND TRACTOR PULLERS ASSOCIATION BY OCTOBER 31ST OF EACH YEAR.
    - a. THE BOARD OF DIRECTORS ALONG WITH A CLUB PRESIDENT AND TWO TECH PEOPLE FROM EACH MEMBER ORGANIZATION WILL MEET FOR A GENERAL DISCUSSION THE FIRST SUNDAY IN NOVEMBER.
    - b. THESE PROPOSALS WILL GO TO THE BOARD OF DIRECTORS MEETING TO BE VOTED ON BY THE BOARD AS TO WHICH PROPOSALS GO TO THE ANNUAL MEETING FOR A YES OR NO VOTE.
  13. ALL PULLS SANCTIONED BY MSTTPA, ALL PARTICIPANTS WILL PURCHASE A VEHICLE COMPETING MEMBERSHIP.
  14. AT ALL MSTTPA PULLS NO OTHER ASSOCIATION MEMBERSHIP IS REQUIRED.
  15. MSTTPA, ITS TECH OFFICIALS AND MEMBER CLUBS RESERVE THE RIGHT TO CHECK ANY EXTERNAL ITEM. THESE CHECKS MAY BE MADE BEFORE OR AFTER CLASS HAS BEEN RUN. ANY INTERNAL CHECK (CUBIC INCHES, CAM LIFT, ETC) WILL REQUIRE A FORMAL PROTEST, WITH FEE BEING PAID. IF FOUND ILLEGAL, ALL POINTS AND MONIES EARNED IN TRUCK OR TRACTOR CLASS OR CLASSES RUN SHALL BE FORFEITED. COMPETITOR MUST PROVE TO TECH OFFICIALS THEY ARE LEGAL BEFORE PULLING AT NEXT MSTTPA SANCTIONED EVENT.
  16. MAINE STATE TRUCK & TRACTOR PULLERS ASSOCIATION RESERVES THE RIGHT TO ACCEPT OR REJECT ANY APPLICATION FOR MEMBERSHIP.

# **MAINE STATE TRUCK AND TRACTORS PULLERS ASSOCIATION, INC. POINT REGULATIONS**

1. ALL PULLS AT FAIRS THAT ARE MEMBERS OF THE MAINE ASSOCIATION OF AGRICULTURAL FAIRS WILL BE CONSIDERED A MAINE STATE TRUCK AND TRACTOR PULLERS ASSOC. CHAMPIONSHIP SERIES PULL, IF THIS PULL HAS BEEN APPROVED BY MSTTPA.
  - a. MSTTPA POINTS PULL DETERMINED ON PREVIOUS YEARS DATES AND EVENTS FIRST. WHERE THERE IS A CONFLICT IN DATES, A FAIR PULL WILL GET THE DATE OVER A NON-FAIR PULL. ANY AND ALL NEW DATES WOULD HAVE TO BE APPROVED BY MSTTPA BOARD OF DIRECTORS ON AN INDIVIDUAL BASIS.
2. IN ADDITION TO THE FAIR PULLS, EACH PULLING ASSOCIATION AND/OR CLUB THAT HAS PAID THE CHARTER FEE BY APRIL 1ST WILL BE ALLOWED 4 (FOUR) PULLS TO BE CONSIDERED A MAINE STATE TRUCK AND TRACTOR PULLERS ASSOCIATION, INC. CHAMPIONSHIP SERIES POINTS PULL.
  - a. FOR THE FIRST 2 ADDITIONAL PULLS THE CHARTER CLUB WILL ONLY BE RESPONSIBLE FOR THE USUAL FEES DUE MSTTPA. ANY ADDITIONAL PULLS WILL REQUIRE THE CHARTER CLUB TO PAY THE \$250 INSURANCE FEE PLUS THE USUAL FEES DUE MSTTPA.
3. IN ORDER TO BE A MSTTPA CHAMPIONSHIP SERIES POINTS PULL, THE PROMOTER MUST HAVE A SIGNED PROMOTER CONTRACT AND A COMPLETE PULL INFORMATION SHEET, INCLUDING A CLASS LIST, TO THE SECRETARY AT LEAST 60 (SIXTY) DAYS PRIOR TO THE EVENT, WITH A RAIN-DATE IF APPLICABLE.
4. POINTS WILL GO TO EACH VEHICLE WITH A MSTTPA REGISTRATION IDENTIFICATION NUMBER ONLY.
5. POINTS WILL GO TO EACH VEHICLE, REGARDLESS OF WHO THE DRIVER IS.
6. THE PULLING CLUB IS RESPONSIBLE FOR REPORTING CORRECT PULL RESULTS TO MSTTPA SECRETARY, AS WELL AS, FORWARDING ALL PAPERWORK AND MONEY INTO THE STATE SECRETARY'S OFFICE. THIS MUST BE POSTMARKED NO LATER THAN 7 DAYS AFTER EVENT HAS RUN. IF THE ABOVE STATED RULE IS NOT ADHERED TO, THE PRESIDENT, VICE PRESIDENT, AND BOARD OF DIRECTORS WILL REVIEW THE CASE AND DETERMINE IF A PENALTY IS WARRANTED. PENALTIES MAY INCLUDE THE PULLING ORGANIZATION AND/OR CLUB FORFEITING THEIR \$125.00 CHARTER FEE, MSTTPA PULLING POINTS NOT BEING AWARDED, MSTTPA INSURANCE BEING REVOKED, AND/OR THE PULLING CLUB BEING SUSPENDED FROM SPONSORING A MSTTPA EVENT FOR UP TO ONE YEAR & TEN DAYS.
7. ALL PULLING POSITIONS WILL BE DETERMINED BY A DRAWING.



8. EACH VEHICLE MAY BE ENTERED IN MORE THAN ONE CLASS, IF ALLOWED FOR THAT DIVISION, BUT ONLY ONCE IN EACH CLASS.
9. ALL CLASSES WILL BE GIVEN 2 (TWO) HOOKING POINTS FOR SHOWING UP TO EVERY EVENT.
10. IF NOT ENOUGH VEHICLES FOR A FULL CLASS, EACH REGISTERED VEHICLE WILL BE PERMITTED TO MAKE A PULL & RECEIVE POINTS.
11. ONCE A PULLER HAS SCRATCHED FROM A CLASS, HE MAY NOT RE-ENTER.
12. ONCE A PULLER HAS HOOKED TO THE SLED, WHETHER HE CAN MAKE A MEASURABLE PULL OR NOT, WILL RECEIVE THEIR HOOK POINT OR POINTS.
13. IN ORDER TO RECEIVE MSTTPA POSITION POINTS, THE CONTESTANT MUST HOOK AND HAVE MADE A MEASURABLE PULL. IF THE VEHICLE BREAKS ON THE GROUNDS, THE VEHICLE WILL RECEIVE HOOK POINTS FOR CLASS IT WAS REGISTERED IN PRIOR TO BREAKING.
14. ANY VEHICLE THAT HOOKS TO THE SLED AND MAKES A MEASURABLE PULL SHALL BE CONSIDERED TO HAVE MADE AN OFFICIAL HOOK, EVEN IF THE SLED IS RESET AND VEHICLE CANNOT RE-HOOK.
15. ALL PULLS MADE DURING A CONTEST WILL BE MEASURED. ALL PULLS WILL BE MEASURED TO THE NEAREST INCH IN FRONT WHERE THE SLED STOPS.
16. VEHICLES HAVING PRE-REGISTERED IN ANY CLASS, WHICH IS CANCELED DUE TO INCLEMENT WEATHER, WILL RECEIVE THEIR HOOK POINT OR POINTS.
17. IF A VEHICLE IS LEGAL WHEN HOOKED TO THE SLED, AND IF BREAKAGE OCCURS WHILE UNDER THE GREEN FLAG, DUE TO UNFORESEEN CIRCUMSTANCES, THE PULL WILL BE MEASURED, WITH THE EXCEPTION OF LOSS OF BALLAST OR SAFETY EQUIPMENT.
18. ALL VEHICLES DISQUALIFIED FOR BEING ILLEGAL BY MSTTPA RULES WILL NOT RECEIVE POINTS.
19. IF DISQUALIFIED FOR GOING OUT OF BOUNDS IN A CLASS LESS THAN FULL, A DRIVER WILL RECEIVE LAST PLACE POINTS. IF MORE THAN ONE VEHICLE IS DISQUALIFIED FOR OUT OF BOUNDS IN THE SAME CLASS, POSITIONS WILL BE DETERMINED BY MEASUREMENT.
20. A PERSON CAN REBUILD MID-SEASON AND RETAIN PREVIOUS POINTS WITH THE OLD REGISTRATION NUMBER AS LONG AS THAT PERSON ISN'T RUNNING THE OLD VEHICLE ON THAT NUMBER.

21. A VEHICLE OWNER MAY SELL THE VEHICLE INCLUDING THE NUMBER AND ACCUMULATED POINTS. IF POINTS ARE SOLD WITH THE VEHICLE, ALL POINTS FOR ALL CLASSES MUST BE SOLD.
22. IF TWO OR THREE MEMBERS OWN A VEHICLE TOGETHER, THEY MUST USE THE SAME NUMBER. EACH MUST HAVE A COMPETING MEMBERSHIP WITH MSTTPA.
23. ALL AWARDS FOR THE MSTTPA CHAMPIONSHIP SERIES PULLS WILL BE GIVEN AT THE ANNUAL BANQUET AT THE END OF THE SEASON. ALL CLASSES WILL RECEIVE THE SAME AWARD, EITHER A TROPHY OR PLAQUE. THE NUMBER OF AWARDS WILL BE GIVEN OUT ACCORDING TO THE FOLLOWING GUIDELINES: (BASED ON THE AVERAGE NUMBER OF VEHICLES AT EACH EVENT.)

<u>AVERAGE/EVENT</u>	<u># OF AWARDS PER CLASS</u>
1-2	1 AWARD PER CLASS
3-4	2 AWARDS PER CLASS
5-7	3 AWARDS PER CLASS
8-9	4 AWARDS PER CLASS
10-12	5 AWARDS PER CLASS
13 AND OVER	6 AWARDS PER CLASS

## MAINE STATE TRUCK AND TRACTOR PULLERS ASSOCIATION INC. OPERATION OF CONTEST DISCIPLINARY PROCEDURE

- A. RULE INFRACTIONS CAN BE SUBJECT TO A PENALTY OF UP TO 5 VEHICLE POINTS, AND AN AUTOMATIC PROBATION FOR THE DRIVER FOR THE BALANCE OF THE COMPETITION SEASON. THIS WILL BE AT THE PROMOTER'S DISCRETION.
- B. THE SECOND OFFENSE FOR THAT DRIVER WITHIN THE PROBATIONARY PERIOD COULD INCUR A SUSPENSION OF UP TO 1 YEAR AND 1 PULL. ANY SUSPENSIONS WILL BE AT THE DISCRETION OF THE PRESIDENT, VICE PRESIDENT, AND BOARD OF DIRECTORS OF THE MSTTPA; AND WILL BE HONORED STATE WIDE BY THE MSTTPA. ANY SUSPENSION CAN INCLUDE THE DRIVER, VEHICLE, AND/OR OWNER.

## FIRE EXTINGUISHERS

ALL VEHICLES PULLING FOR MSTTPA POINTS ARE REQUIRED TO HAVE A FIRE EXTINGUISHER IN THE COMPETITION VEHICLE. (EXCLUDING LAWN & GARDEN AND STOCK FARM TRACTORS) WITH THE EXCEPTION OF LAWN & GARDEN AND MINI TRACTORS; ALL VEHICLES MUST HAVE AN AREA ABOVE AND AROUND THE HITCH POINT 6" WIDE AND 12" HIGH TO BE KEPT AT ALL TIMES TO ALLOW FOR THE HOOK TO BE HOOKED WITH OUT INTERFERENCE.

- C. "MAINE STATE TRUCK AND TRACTOR PULLERS ASSOC. (MSTTPA) WILL NOT SUPPORT CHARTERED CLUBS WHO ALLOW COMPETITORS TO PARTICIPATE IN MSTTPA SANCTIONED EVENTS W/KNOWN SAFETY VIOLATION(S). A CHARTER CLUB THAT KNOWINGLY AND REPEATEDLY ALLOWS SUCH ACTIVITY MAY HAVE IT'S MSTTPA CHARTER REVOKED AT THE DISCRETION OF THE MSTTPA BOARD (COMPRISED OF THE ACTIVE MSTTPA PRESIDENT, VICE PRESIDENT AND BOARD OF DIRECTORS). THE MSTTPA BOARD WILL DETERMINE IF OR WHEN THE CHARTER CLUB MAY APPLY FOR REINSTATEMENT OF ITS CHARTER. ANY CHARTER CLUB WHOSE CHARTER IS REVOKED WILL FORFEIT ALL MONIES PAID TO MSTTPA AND MSTTPA INSURANCE. ALL OUTSTANDING MONIES OWED TO MSTTPA BY SAID CLUB WILL BE DUE IN FULL AT SUCH TIME THE CHARTER IS REVOKED.

ANY MSTTPA BOARD MEMBER MAY REPORT TO THE MSTTPA BOARD ANY CHARTER CLUB KNOWN TO BE ALLOWING COMPETITORS TO REPEATEDLY VIOLATE SAFETY RULES. AT ANY POINT DURING A PULLING SEASON AND AFTER RECEIVING THE SECOND REPORTED OFFENSE BY A CHARTERED CLUB, ANY ONE MEMBER OF THE MSTTPA BOARD MAY REQUEST A MEETING TO ADDRESS AND DETERMINE ANY ACTION AGAINST THE REPORTED CLUB. A MAJORITY OF THE MSTTPA BOARD MUST BE PRESENT AT SUCH MEETING IN ORDER FOR THE MEETING TO BE VALID. A MAJORITY VOTE OF THE MSTTPA BOARD MEMBERS PRESENT AT THE MEETING WILL BE UPHELD AS THE FINAL DECISION BY THE MSTTPA BOARD.

SAFETY RULES ARE OPEN TO INTERPRETATION. THEREFORE A SAFETY VIOLATION MUST RECEIVE MAJORITY AGREEMENT FROM THE MSTTPA BOARD MEMBERS PRESENT AT SUCH MEETING IN ORDER TO BE CONSIDERED A SAFETY VIOLATION.

1. PULLING VEHICLES MUST BE OPERATED IN A SAFE MANNER AT

ALL TIMES WITHIN THE CONFINES OF THE TRACK, PITS AND STAGING AREAS. OFFICIALS HAVE THE RIGHT TO STOP AND DISQUALIFY ANY VEHICLE IF IT IS NOT BEING OPERATED IN SUCH A MANNER AS WOULD BE CONSIDERED SAFE.

2. OPERATOR MUST REMAIN SEATED DURING THE PULL AND MUST HAVE COMPLETE CONTROL OF THE VEHICLE AT ALL TIMES.
3. ONLY THE DRIVER WILL BE ALLOWED ON A VEHICLE WHEN IT IS BEING TOWED OR DRIVEN, NO RIDERS.
4. OBVIOUS CONSUMPTION OF ALCOHOLIC BEVERAGES WILL BE GROUNDS FOR DISQUALIFICATION & OR BARRED FROM COMPETITION.

5. ANY UNSPORTSMANLIKE CONDUCT WILL BE AN IMMEDIATE DISQUALIFICATION. ANY PURSES WON WILL BE RENEGED. THE DRIVER, VEHICLE, AND/OR OWNER MAY NOT BE ALLOWED TO PULL FOR THE CONTINUATION OF THE COMPETITION AT THE DISCRETION OF THE PRESIDENT, VICE PRESIDENT AND BOARD OF DIRECTORS OF THE MSTTPA. SUSPENSION CAN BE ONE YEAR AND ONE PULL AND WILL BE HONORED STATEWIDE BY THE MAINE STATE TRUCK AND TRACTOR PULLERS ASSOCIATION.
6. ALL PULLS MUST START WITH A TIGHT CHAIN. CONTESTANTS WILL BE ALLOWED A TOTAL OF TWO ATTEMPTS AND 100' TO THE START THE SLED IF THE DRIVER LETS OFF THE THROTTLE BEFORE 100' HE WILL GET A SECOND ATTEMPT, EVEN IF GOING BEYOND 100'. IF NO EFFORT IS MADE TO BACK-OFF THROTTLE, NO SECOND ATTEMPT WILL BE GIVEN. THE INTENT IS FOR DRIVERS NOT TO SLAM ON THE BRAKES TO STOP BEFORE 100' (OR AT ANY TIME), BUT TO COME TO AS SMOOTH A STOP AS POSSIBLE. JERKING OF THE SLED BY BACKING OUT OF THE THROTTLE WILL BE GROUNDS FOR DISQUALIFICATION BY TRACK OFFICIALS. TRACK OFFICIALS WILL USE THEIR OWN JUDGMENT ON THIS CALL.
7. EACH CONTESTANT HAS THE PRIVILEGE OF, AND THE RESPONSIBILITY FOR SPOTTING THE SLED FOR BOTH OF HIS/HER ATTEMPTS. PULL BACK TRACTOR OPERATOR/SLED OPERATOR MUST BE NOTIFIED OF WHERE CONTESTANT WISHES SLED PLACED WHEN PREVIOUS CONTESTANT UNHOOKS FROM THE SLED. USE OF CREW MEMBERS IS RECOMMENDED IN SPOTTING SLED TO EXPEDITE THE SHOW.
8. SLED WILL BE TOWED BACK OR FORWARD TO THE STARTING LINE BEFORE EACH ATTEMPT. NO OFFICIAL PULL MAY START BEYOND STARTING LINE IN EITHER DIRECTION. ALL SLEDS TO BE STARTED WITH FRONT OF PAN EVEN WITH STARTING LINE AND IN GEAR.
9. AN ATTEMPT IS DEFINED AS MOVING THE SLED A MEASURABLE DISTANCE (1" OR GREATER).
10. ALL PULLS MADE DURING A CONTEST WILL BE MEASURED. ALL PULLS WILL BE MEASURED TO THE NEAREST INCH IN FRONT WHERE THE SLED STOPS.
11. VIOLATION OF ANY RULE SHALL CONSTITUTE DISQUALIFICATION.
12. PULLING VEHICLE MUST REMAIN WITHIN BOUNDARIES OF CONTEST COURSE DURING A PULL OR WILL BE DISQUALIFIED. THE VEHICLE'S TIRES MAY NOT TOUCH THE BOUNDARY LINE. SLED PAN MUST BE WITHIN BOUNDARY LINES AT THE START OF PULL. CHALK LINE IS TO CONSTITUTE TRACK BOUNDARIES. THE CHALK LINE MUST BE MAINTAINED TO THE BEST OF THE TRACK CREWS ABILITY OR THEY WILL NOT COUNT. THE OUT OF BOUNDS DECISION IS TO BE MADE BY THE FLAGMAN AND BY NOBODY ELSE. HE MAY ASK FOR HELP ON THE DECISION, BUT CANNOT BE TOLD TO DISQUALIFY SOMEBODY.

- a. THE TRACK WILL BE MARKED TO 350'. IF USING A FLOATING FINISH LINE, THE PULL WILL END AT 350'. DECISIONS OF THE TRACK OFFICIALS WILL BE FINAL
13. EXCESSIVE LOSS OF LIQUID BY A PULLING VEHICLE WHILE IN FORWARD MOTION, UNDER THE GREEN FLAG, DURING A CONTEST ON THE TRACK WILL BE CAUSE FOR DISQUALIFICATION, UNLESS DUE TO INTERNAL BREAKAGE. (EXCESSIVE IS DEFINED AS ANY STEADY OR INTERMITTENT STREAM DISCHARGED ON THE TRACK, OR A SPOT EQUIVALENT TO MORE THAN 8" DIAMETER.)
  14. IF A VEHICLE IS LEGAL WHEN HOOKED TO THE SLED, AND IF BREAKAGE OCCURS WHILE UNDER THE GREEN FLAG DUE TO UNFORESEEN CIRCUMSTANCES, THE PULL WILL BE MEASURED, WITH THE EXCEPTION LOSS OF BALLAST OR SAFETY EQUIPMENT.
  15. ONLY WHEN THE ORIGINAL MECHANICAL METHOD OF STARTING FAILS TO WORK, WILL TOW STARTING BE AUTHORIZED.
  16. ALL PULLING VEHICLES MUST BE ABLE TO DRIVE ON THE TRACK & BACK UP TO THE SLED AT THE STARTING LINE. THEY MUST ALSO BE ABLE TO BACK UP TO UNHOOK AND DRIVE OFF THE TRACK ON THEIR OWN POWER UNLESS BREAKAGE OCCURS AT THE EVENT OR VEHICLE WILL BE DISQUALIFIED. MINI TRACTORS ARE EXEMPT FROM BACK UP AND DRIVE OFF PORTION OF THIS RULE.
  17. AT ANY PULL IT IS MANDATORY FOR ALL DRIVERS TO ATTEND ANY PARTICULAR DRIVERS MEETING, WHICH MAY BE HELD BY THE PROMOTER AND/OR OFFICIALS.
  18. THE MAINE FAIR ASSOC. AND MAINE STATE TRUCK AND TRACTOR PULLERS ASSOC. ASSUMES NO RESPONSIBILITY FOR LOSS, THEFT, AND OR INJURY TO THE PARTICIPANT OR PROPERTY COMPETING.
  19. DRIVERS MUST BE AT LEAST 18 YEARS OF AGE, OR 16 YEARS WITH PARENTAL OR GUARDIAN AND NOTARY PUBLIC SIGNED CONSENT; TO BE CO-SIGNED BY A MSTTPA DIRECTOR IF AT AN EVENT: STOCK LAWN AND GARDEN AND NON AUTOMOTIVE ARE EXCLUDED FROM THIS.
  20. ALL DRIVERS WILL WEAR AND SECURE DOT APPROVED HELMETS FOR SAFETY REASONS WITH THE EXCEPTION OF ALL DRIVERS OF ALL MSTTPA STOCK CLASSES, BUT FOR SAFETY REASONS THEY ARE RECOMMENDED.
  21. CLASSES WILL BE SELECTED BY A PULL COMMITTEE.
  22. PULLING POSITIONS WILL BE DETERMINED BY A DRAWING.
  23. ONLY ONE DRIVER MAY DRIVE THE SAME VEHICLE IN THE SAME CLASS. ALL VEHICLES WISHING TO COMPETE IN MORE THAN ONE CLASS MUST CONFORM TO THE RULES AND SAFETY REGULATIONS OF EACH CLASS.
  24. ALL DRIVERS SHOULD BE CLEAN AND NEATLY ATTIRED. VEHICLES SHOULD BE CLEAN AND PAINTED. RECOMMEND AGAINST USING OBSCENITIES ON THE VEHICLES.

25. ALL VEHICLES MUST BE IN NEUTRAL OR PARK WHILE BEING HOOKED AND UN-HOOKED TO THE SLED.
26. CLASSES MAY BE CANCELED IF LESS THAN THREE ENTRIES. PULLER MAY PULL ON MSTTPA POINT RULES IF APPLICABLE.
27. ALL SLEDS MUST USE KILL SWITCH ACTIVATOR ROPE.
28. DRIVER MUST REMAIN SEATED AND WITHIN CONFINES OF CAB, WHILE HOOKED TO SLED, WHILE IN PULLING MOTION, UNLESS OTHERWISE INSTRUCTED BY A PULLING OFFICIAL. SEAT BELTS ARE REQUIRED IN VEHICLES.
29. EXHIBITION PULLS WILL BE ALLOWED PROVIDED IT IS DONE WITH THE PROMOTER AND MEMBER CLUBS AGREEMENT AND PASS TECH INSPECTION OF MEMBER CLUB. ALL VEHICLES MUST MEET CURRENT MSTTPA OR NTPA SAFETY STANDARDS AND THE DRIVER MUST BE A MSTTPA COMPETING MEMBER.
30. ALL 2 WD & 4 WD PULL TRUCKS COMPETING UNDER MSTTPA RULES MAY JUMP ONLY (1) ONE CLASS. EXAMPLE: PRO-STOCK MAY JUMP TO SUPER STOCK, BUT NOT TO MODIFIED, OR SUPER STOCK MAY JUMP TO MODIFIED. ALL TRUCK COMPETING MUST MEET ALL SAFETY REQUIREMENTS IN EACH CLASS HE IS COMPETING IN.
31. ALL TRUCKS AND TRACTORS USING ALCOHOL FUEL IT IS MANDATORY TO WEAR A FIRE SUIT, CONSISTING OF A MINIMUM OF ONE (1) LAYER NOMEX 3 OR THE EQUIVALENT OF SF1 CERTIFICATION.
32. ANY NON-SANCTIONED PULL WILL NOT BE COVERED BY MSTTPA INSURANCE, UNLESS THE CLUB PUTTING THE PULL ON WANTS TO PAY THE COST THEMSELVES. (APPROXIMATELY \$250.00 PER EVENT).
33. REGISTRATION FOR THAT EVENT WILL BE CLOSED 1/2 HOUR PRIOR TO START OF PULL. (IF SCHEDULED TO START AT 1:00, REGISTRATION STOPS AT 12:30.)
34. RUBBER STRAPS ARE NOT ALLOWED TO SECURE WEIGHTS OR PULLING VEHICLES DURING COMPETITIVE EVENTS.
35. THE USE OF A CERTIFIED E-VAC SYSTEM IS ALLOWED ON ENGINES RUNNING IN ALL CLASSES OF MSTTPA WITH THE EXCEPTION OF STOCK CLASSES AND FARM TRACTORS.
36. AT A MSTTPA SANCTIONED EVENT, ANY COMPETITOR WHO DOES NOT HOLD A CURRENT MSTTPA MEMBERSHIP AND THE VEHICLE DRIVEN BY THE NON-MSTTPA COMPETITOR WILL BE BARRED FROM COMPETITION AT ALL MSTTPA SANCTIONED EVENTS FOR 1 YEAR AND 10 DAYS. BOTH THE COMPETITOR AND THE VEHICLE WILL BE BARRED.

## **EVENT PROCEDURE AND REQUIREMENTS**

1. ALL BOUNDARIES SHOULD BE LIMED. A SAFETY RUN OFF AREA OF 1/3 THE LENGTH OF THE TRACK IS REQUIRED FOR ALL PULLS.
2. ALL TRACKS SHOULD BE MAINTAINED AND PACKED.

3. NO ONE IS ALLOWED ON THE TRACK EXCEPT FOR THE TRACK OFFICIALS WHEN THE VEHICLE IS UNDER THE GREEN FLAG.
4. ALL PULLS SHOULD OPERATE WITH 2 FLAG MEN. STARTING FLAG MAN WILL BE RESPONSIBLE FOR THE READINESS OF THE TRACK, PULLING MACHINE, AND CONTESTANT. THE SECOND FLAG MAN WILL BE RESPONSIBLE FOR THE BALANCE OF THE COURSE, INCLUDING WHEN THE PULL ENDS.
5. ALL OFFICIAL WEIGHTS INCLUDE DRIVER, VEHICLE WITH OIL, WATER, AND FUEL, READY TO COMPETE. ALL DRIVERS MUST WEIGH IN WITH PULLING VEHICLE WHEN IT IS OFFICIALLY WEIGHTED. NO VEHICLES WILL BE ALLOWED PAST THE SCALES THAT EXCEED CLASS WEIGHT. NO ADDING FUEL OR WEIGHTS UNLESS RE-WEIGHED. WEIGHING OUT TO BE AT THE DISCRETION OF THE TRACK JUDGE.
6. SHOULD A PULLER MOVE MORE THAN 200 LB. FORWARD FROM THE REAR OF THE VEHICLE, THE DRAW BAR MUST BE REMEASURED BEFORE PULLING, AT THE DISCRETION OF TRACK OFFICIAL.
7. DRAW BAR CAN BE RE-MEASURED AFTER PULL AT THE DISCRETION OF TRACK OFFICIAL. IT IS RECOMMENDED TO RE-MEASURE IN THE SAME LOCATION AS THE ORIGINAL MEASUREMENT.
8. IT IS RECOMMENDED THAT THE PROMOTER PROVIDE A MINIMUM OF 2 FIRE EXTINGUISHERS TO BE ON OR NEAR THE TRACK DURING THE PULL.

## **TEST PULL AND OPTIONS**

1. NUMBER ONE PULLER WILL TEST PULLER AND MAY TAKE PULL IF WEIGHT TRANSFER IS DEEMED RIGHT, OR HE MAY IMMEDIATELY TAKE HIS SECOND PULL, OR HE MAY PULL IN SIXTH POSITION. SIXTH POSITION IS DEFINED AS THE POSITION IMMEDIATELY FOLLOWING THE NEXT FIVE SCHEDULED COMPETITORS AND THEIR ATTEMPTS.
2. THE NUMBER ONE OR TEST PULLER ONLY IS NOT TO BE DISQUALIFIED OR MEASURED FOR RUNNING OUT OF BOUNDS ON THE FIRST ATTEMPT ONLY. HE IS TO BE DISQUALIFIED ON SECOND OR SUBSEQUENT ATTEMPTS IF HE GOES OUT OF BOUNDS.
3. IF THE WEIGHT TRANSFER NEEDS FURTHER ADJUSTMENT, THE 1ST PULLER AFTER EACH ADJUSTMENT WILL BE THE TEST PULLER.
  - a. IF #1 TEST PULLER BREAKS AND CAN NOT CONTINUE BEFORE REACHING THE 100 FOOT MARK, THE NEXT PULLER SHALL BECOME WITH TEST PULLER.
4. IF THE CLASS IS RESTARTED, ALL CONTESTANTS HAVING PULLED PREVIOUSLY WILL HAVE THE OPTION OF DROPPING DOWN SIX POSITIONS OR PULLING IN ORIGINAL ORDER.

5. IF THE FIRST FIVE VEHICLES IN A GIVEN CLASS MAKE A FULL PULL, THE CLASS WILL BE AUTOMATICALLY STARTED OVER.
6. ALL DECISIONS ON RE-PULLS ARE TO BE MADE BEFORE VEHICLE LEAVES THE TRACK.
7. ON ANY RE-PULL CAUSED BY A CONTEST MALFUNCTION, THE PULLER, AT HIS DISCRETION MAY DROP BACK 6 POSITIONS.
8. ANY DISQUALIFICATION ON THE FIRST ATTEMPT BARS A SECOND ATTEMPT. SHOULD CLASS BE RESTARTED, PULLER DISQUALIFIED WILL BE ALLOWED TO PULL IN POSITION DRAWN.
9. CONTESTANT MUST PULL AT POSITION DRAWN WITHIN THREE MINUTES OF TIME SLED IS AT READINESS AND DELAY WILL MEAN DISQUALIFICATION. IF PRESIDING JUDGE IS NOTIFIED HE MAY DROP CONTESTANT HAVING MECHANICAL PROBLEMS TO THE BOTTOM OF THE CLASS.
10. PULLER WILL BE ABLE TO DROP TO THE BOTTOM OF THE CLASS IF BREAKAGE OCCURS ON FIRST ATTEMPT, IF NOT PAST THE 75', HE WILL GET A TOTAL OF TWO CHANCES.
11. IF THE LAST VEHICLE IN A CLASS EXPERIENCES MECHANICAL PROBLEMS, IT SHOULD BE ALLOWED 6 MINUTES TO HOOK AND MAKE AN ATTEMPT.

## **PULL OFFS**

1. IN A PULL OFF, EACH CONTESTANT IN HIS/HER TURN WILL BE ALLOWED ONE ATTEMPT TO MAKE A MEASURABLE PULL.
2. IF THE FIRST CONTESTANT SUCCEEDS IN MAKING A FULL PULL, ALL CONTESTANTS MUST PULL AT THAT SETTING UNLESS IN TRACK JUDGES OPINION, THE SLED OPERATOR HAS MADE A MISTAKE.
3. ORDER OF PULL WILL BE THE ORDER IN, WHICH THE VEHICLES INVOLVED, MADE FULL PULLS, UNLESS THERE HAS BEEN A SLED SETTING CHANGE BY THE TRACK JUDGE. NO DROPPING SIX POSITIONS IN A PULL OFF.
4. IF A PULL OFF IS NOT RUN ON THE SAME TRACK OR SAME SLED, OR SAME DAY, THE FIRST PULLER WILL HAVE THE OPTION OF TAKING THE FIRST PULL OR DROPPING SIX PLACES.
5. IN THE CASE OF A PULL OFF NOT COMPLETED BECAUSE OF RAIN, CURFEW, ETC., PURSE MONIES & POINTS FOR PLACES INVOLVED WILL BE DIVIDED EVENLY BETWEEN ALL THOSE QUALIFIED IN THE PULL OFF.

## **INCLEMENT WEATHER**

1. THE PROMOTER AND DIRECTOR OF OPERATIONS SHALL MUTUALLY DETERMINE IF AND WHEN AN EVENT SHALL BE STOPPED BECAUSE OF INCLEMENT WEATHER OR TRACK CONDITIONS WITH THE PULL DIRECTOR HAVING FINAL SAY AS TO SAFETY.



2. IN THE EVENT THAT THE PROMOTER ADDS UNSCHEDULED CLASSES, INCLUDING INCLEMENT WEATHER CLASSES, TO THOSE ALREADY SCHEDULED, THE UNSCHEDULED OR RAINED OUT CLASSES WILL BE HELD FOLLOWING THE SCHEDULED CLASSES.
3. PURSE MONEY WILL BE PAID TO THOSE CLASSES WHICH ARE COMPLETED ACCORDING TO THE RESULTS. ANY CLASS STARTED BUT NOT COMPLETED BECAUSE OF RAIN OR STOPPAGE OF THE EVENT, THE PURSE WILL BE DIVIDED EQUALLY BETWEEN THOSE ENTERED IN THAT CLASS. FOR CLASSES NOT STARTED THE PROMOTER WILL REFUND ALL ENTRY FEES.

## **ADDITIONAL CAUSES FOR DISQUALIFICATION**

1. LOSS OF BALLAST WEIGHT UNDER THE GREEN FLAG.
2. LOSS OF SAFETY EQUIPMENT, AND FAILURE OF SAFETY EQUIPMENT TO FUNCTION WHILE UNDER THE GREEN FLAG.
3. ILLEGAL FUEL (NITROMETHANE, NITROUS OXIDE OR OTHER OXYGEN CARRIERS OR COMBUSTION ACCELERATORS).
4. ILLEGAL EQUIPMENT.
5. LEAVING THE STARTING LINE UNDER THE RED FLAG.
6. THE DECISION OF THE TRACK JUDGE IS FINAL AND SHALL NOT BE APPEALED; PROVIDED, HOWEVER, THAT WITH A SHOWING OF REASONABLE AND GOOD CAUSE, THE TRACK JUDGE MAY, WITHOUT LIABILITY, REVERSE OR REVISE HIS DECISION. CALLS OF JUDGMENT ARE NOT SUBJECT TO APPEAL AND SHALL BE FINAL.
7. RAIN CAPS ARE NOT ALLOWED IN ANY CLASS

## **PROTEST PROCEDURE FOR ALL CLASSES**

1. PROTEST MUST BE SUBMITTED IN WRITING TO TRACK JUDGE WITHIN TEN MINUTES AFTER CLASS IS OVER. PROTESTS MUST BE ACCOMPANIED WITH PROTEST FEE. A COMPETING MEMBER IN THE CLASS IS THE ONLY ONE THAT CAN FILE A PROTEST.
  - a. ANY AND ALL PROTESTS MUST BE ANSWERED WITHIN 30 MINUTES OF THE COMPLETION OF THE EVENT AT WHICH PROTEST ORIGINATED. RESULTS AND PRIZE MONEY WILL BE HELD UNTIL PROTEST IS SATISFIED.
2. CHECK MAY BE MADE AT ANYTIME BY TECHMEN. THERE IS NO CHARGE FOR EXTERNAL CHECKS. CHARGE IS \$150.00 TO CHECK BORE AND STROKE. \$1,000.00 CHARGE WILL TEAR MOTOR DOWN. THE PROTESTED VEHICLE WILL BE IMPOUNDED. FEE WILL GO TO THE PERSON IN THE RIGHT.
  - a. STREET CLASSES WILL HAVE THE OPTION OF DYNO TESTING FOR \$1,000.00. THE DRIVER WHO IS BEING PROTESTED WILL HAVE THE OPTION TO DYNO OR TEAR DOWN. THE PROTESTED VEHICLE WILL BE IMPOUNDED. FEE WILL GO TO THE PERSON IN THE RIGHT.

- b. THE PERSON IN THE WRONG WILL BE REQUIRED TO PAY ALL CLUB EXPENSES INVOLVED WITH TOWING, IMPOUNDING, AND HAVING VEHICLE DYNO TESTED. THE PERSON RESPONSIBLE FOR THESE EXPENSES WILL NOT BE ALLOWED TO COMPETE UNTIL CLUB IS PAID FOR THESE EXPENSES.
3. THE COMPETITOR FILING A PROTEST, REQUESTING A TEAR DOWN OR DYNO TEST, IN THE STREET STOCK CLASSES, IS AUTOMATICALLY SUBJECT TO A TEAR DOWN HIMSELF.
4. DYNO PARAMETERS WILL BE DETERMINED BY FACTORY SPECS FOR THAT VEHICLE.
5. WHEN VEHICLE IS FOUND ILLEGAL, THE VEHICLE/DRIVER WILL BE DISQUALIFIED UNTIL HE PROVES HIMSELF LEGAL AND WILL BE HONORED STATEWIDE.
6. OWNER/DRIVER HAS THE OPTION OF HAVING TECHMAN'S INSPECTION DONE IN PRIVATE IF PROTESTED.
7. NO VIDEO.

## **PROTEST PROCEDURE FOR LAWN & GARDEN TRACTORS**

1. ANY OWNER OF A COMPETING TRACTOR MAY, FOR A COST OF \$40.00 PROTEST THE EQUIPMENT OF ANOTHER COMPETITOR.
2. THE OWNER OF THE PROTESTED TRACTOR MUST TEAR DOWN HIS EQUIPMENT IN THE PRESENCE OF A SAFETY TECH DIRECTOR. IF THE TRACTOR IS FOUND TO BE IN VIOLATION, THE OWNER WILL LOSE PRIZE MONIES. POINTS FOR THE TRACTOR WILL BE FORFEITED, AND THE OWNER, DRIVER, AND THE TRACTOR WILL BE BARRED FROM EVENTS FOR 1 YEAR AND 10 DAYS FROM THE DATE OF THE INFRACTION. THE PROTESTER WILL RECEIVE HIS MONEY BACK. IN CASE THE TRACTOR IS LEGAL, THE \$40.00 WILL BE FORFEITED TO THE OWNER OF THE TRACTOR PROTESTED.

## **2X4 & 4X4 VEHICLE DISQUALIFICATIONS (EXCEPT 4X4 & 2X4 MODIFIED)**

1. ALL VEHICLES MUST HAVE WORKABLE 4 WHEEL BRAKES OR 1 (ONE) DRIVE LINE BRAKE IN COMBINATION WITH 2 WORKING WHEEL BRAKES ON FRONT. BRAKES MUST OPERATE FROM 1 (ONE) FOOT PEDAL IN ORIGINAL LOCATION.
2. FIRE EXTINGUISHERS WITH GAUGES ARE REQUIRED IN ALL CLASSES. THEY MUST BE MOUNTED IN CAB, IN WORKING ORDER AND EASILY ACCESSIBLE TO THE DRIVER.
3. ALL CLASSES WILL BE REQUIRED TO USE ONLY AUTOMOTIVE TYPE FRONT AND REAR AXLE HOUSING.

4. ALL WEIGHTS MUST BE SAFELY SECURED TO THE VEHICLE; MAY NOT EXTEND FORWARD MORE THAN 60" FROM CENTER LINE OF FRONT AXLE; NO WEIGHT IN CAB OR UNDER HOOD. BALLAST & SANDBAGS ARE ALLOWED IF SECURED IN BODY.
5. NO DUAL WHEELS OR CHAINS ALLOWED.
6. ALL TIRES TO RUN IN CORRECT ROTATION; ALL TIRES MUST HAVE RUBBER OR RUBBER COMPOUND CONTACT BETWEEN TIRES AND GROUND.
7. IF ORIGINAL VEHICLE HAS DOORS, THEY MUST BE ON AND CLOSED. ALL DOORS MUST HAVE SINGLE LATCH DESIGN, ALLOWING DOOR TO BE OPENED INSIDE AND OUTSIDE.
8. TRUCK BODY-STYLE MUST HAVE BEEN OR BE AVAILABLE FROM DEALER AS MASS PRODUCED. TRUCK MUST HAVE METAL CAB AND OUTER SKINS. TRUCK MUST HAVE A PRESENTABLE VAN/ PICKUP BED WITH COVER OR FLATBED IN PLACE. TRUCK MUST HAVE HOOD AND GRILL IN PLACE AS INTENDED BY THE MANUFACTURER. CUSTOMIZ- ING ALLOWED.

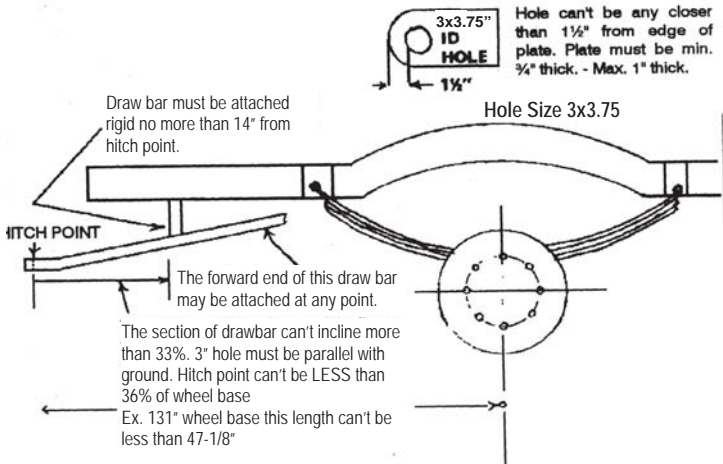

9. ALL 3 CLASSES MUST RUN WITH FULL HOOD EXCEPT EXHAUST. MODIFIED AND SUPER STOCK MAY RUN FUEL SYSTEMS THROUGH HOOD.
10. NO HOLES IN FIREWALLS OR FLOOR BOARDS. NO GAS TANKS, BATTERY, OR RADIATORS IN CAB OF TRUCK UNLESS FACTORY INSTALLED.
11. FRONT AND REAR BUMPERS AND TAILGATE OPTIONAL. FRONT AND REAR GLASS OR PLEXIGLAS REQUIRED.

### **4X4 AND 2X4 FUELS**

1. PUMP GASOLINE, PUMP GASOHOL, AND ALCOHOL (ALCOHOL ALLOWED IN MODIFIED CLASS ONLY.) ALL FUELS MUST PASS FUEL TEST ACCORDING TO NHRA SPECS. ALCOHOL OPTIONAL BY PROMOTER. IF PROMOTER DOES NOT ALLOW ALCOHOL, EVENT WILL NOT BE A MSTTPA CHAMPIONSHIP SERIES POINTS PULL.

## **4X4 & 2X4 PRO-STOCK & SUPERSTOCK HITCH QUALIFICATIONS**

1. FROM POINT OF HITCH TO CENTER OF REAR AXLE SHALL BE NO LESS THAN 36% OF SUPER STOCK OR VEHICLE WHEELBASE. IF CANNOT RUN 36% HITCH BECAUSE BED IS TOO LONG, BED MAY BE CUT TO THE 36% LENGTH. HITCH MUST BE CLEAR AND VISIBLE FOR HOOKUP.
2. DRAW-BAR MUST BE EQUIPPED WITH STEEL HITCHING DEVICE NO LESS THAN 3/4" THICK AND MUST HAVE A 3" OPENING CAPABLE OF ACCEPTING A 3" OD PIPE. CLEVIS MAY BE USED AT JUDGES DISCRETION.
3. NO PART OF HITCH MAY BE INCLINED MORE THAN 33%. DRAW BAR MUST BE HOOKING DEVICE, SECURED FRONT AND BACK, MUST BE SECURED TO MORE THAN 14" FROM HITCHING POINT.
4. HITCH MUST BE RIGID IN ALL DIRECTIONS, SOLIDLY MOUNTED TO VEHICLE FRAME. NO DEVICES MAYBE USED TO RAISE HITCH HEIGHT WHILE PULLING OR IT WILL RESULT IN A DISQUALIFICATION. HIGH POINT OF HITCH CANNOT EXCEED 26" BEFORE, DURING OR AFTER PULL. PULLING POINT CAN BE NO MORE THAN 1-1/2" FROM BACK EDGE OF HITCHING DEVICE. 3" HOLE IN HITCH MUST BE PARALLEL WITH GROUND. NO CLEVIS, CHAIN OR CABLE ALLOWED IN HITCHING DEVICE
5. HITCH HEIGHT FOR 4X4 TRUCKS WILL BE CONSISTENT WITH SPECIFICATIONS FOR EACH INDIVIDUAL CLASS.
6. HITCH: NO PORTION OF VEHICLE MAY INTERFERE WITH SLED, CHAIN OR HOOK DURING PULL OR WHILE BEING HOOKED OR UNHOOKED. AN AREA 6" WIDE AND 12" HIGH IMMEDIATELY ABOVE AND BELOW THE DRAW-BAR MUST BE FREE OF ALL OBSTRUCTIONS (INCLUDING WEIGHTS, WHEELIE BARS AND SECOND DRAW-BARS) FOR EASE OF HOOKING AND UNHOOKING. IF BODY EXTENDS MORE THAN 12" BEHIND POINT OF HOOK, THE OPEN AREA MUST BE 18" ABOVE DRAW-BAR AND 24" WIDE AT THE REAR MOST POINT OF BODY.

## **4X4 DRIVE SHAFT QUALIFICATIONS. PROSTOCK, SUPERSTOCK, MODIFIED & SEMI'S**

1. DRIVE-SHAFT MUST HAVE AT LEAST TWO LOOPS ON EACH SHAFT OR SHIELDING LOOPS MINIMUM 3/4" WIDE, 1/8" STEEL OR 3/8" METAL.
2. MAXIMUM LOOP CLEARANCE 2".
3. NO CABLE OR CHAIN IN ANY CLASS EXCEPT STREET STOCK.
4. VEHICLES THAT HAVE A SHAFT BETWEEN THE TRANSMISSION AND THE TRANSFER CASE NEED ONLY 1 LOOP IF THAT SHAFT IS NOT MORE THAN 12" LONG AND LOOP IS IN THE MIDDLE.

5. ALL DRIVELINE U-JOINTS ARE TO BE ENCLOSED IN A 360 DEGREE SHIELD 1/4" THICK STEEL OR 3/8" METAL. ALL U-JOINT COVERS MUST BE A MINIMUM OF 6" WIDE AND MAXIMUM OF 2" CLEARANCE FROM U-JOINT. SHIELD SHOULD RESTRAIN ANY BROKEN PARTS. JOINT SHOULD NOT BE VISIBLE FROM SIDE, TOP OR BOTTOM.

## **HUB SHIELDS**

1. ALL VEHICLES EXCEPT STOCK FARM TRACTORS MUST HAVE ALL DRIVEN AXLES COVERED WITH A SHIELD WITH A HOLE IN CENTER TO LOCK AND UNLOCK HUBS, HOOKED BEHIND THE WHEEL OR HOOKED ON THE WHEEL WITH BOLTS OR NUTS. NO SNAP ON WHEEL COVERS ALLOWED.
2. ALL SHIELDS MUST BE METAL.

## **STREET STOCK CLASS**

1. ENGINE AND DRIVE TRAIN MUST BE SAME SIZE AS MASS PRODUCED BY FACTORY AND INTENDED BY ORIGINAL MANUFACTURER. FUEL INJECTION WILL BE ALLOWED FOR THAT YEAR TRUCK.
  - a. STREET STOCK 2X4, 6500 LB. - TO BE LEFT UP TO PROMOTER.
  - b. MUST HAVE STOCK APPEARING BUMPER IN STOCK LOCATION.
2. HEADERS ALLOWED BUT MUST BE STREET LEGAL. EXHAUST TO BE STREET LEGAL. DUAL EXHAUST PERMITTED. NO CYLINDER HEAD, CAM SHAFT OR MANIFOLD MODIFICATIONS.
3. TIRES WILL BE ROAD INSPECTABLE & STREET LEGAL. 33" MAXIMUM HEIGHT BY ACTUAL MEASUREMENT. 10" MAXIMUM TREAD WIDTH. 20" MAXIMUM WHEEL ALLOWED
  - a. NO LOADED TIRES.
4. NO DRAW-BARS ALLOWED IN STREET STOCK CLASSES. PULL OFF TRAILER HITCH ONLY. DRAWER BUILT NO HIGHER THAN 24". MUST HAVE A MINIMUM 3" HOLE AND BE PARALLEL TO GROUND. MUST BE IN STOCK LOCATION. THE HOOK POINT WILL BE THE REARWARD MOST POINT ON THE VEHICLE.
5. BLOCKING OR TRACTION BARS ALLOWED IN STREET STOCK CLASSES.
6. DRIVE-SHAFTS MUST BE PROTECTED BY TWO LOOPS OF EITHER STEEL OR CHAIN 1/4" THICK OR 3/4" WIDE 1/8" THICK STEEL, SAFETY OF WHICH AT THE DISCRETION OF JUDGES OR TECHMEN.
7. STREET STOCK NOT TO EXCEED 7000 LB. ANY ADDITIONAL WEIGHT TO BE IN BODY ONLY. MUST BE STATE LICENSE AND STATE INSPECTION SNOWPLOW HEADGEAR WILL BE ALLOWED.
8. HITCH HEIGHT WILL BE 24".
9. IF HITCH HEIGHT IS TOO HIGH YOU CANNOT CHAIN VEHICLE DOWN TO MEET HEIGHT REQUIREMENTS. A SHACKLE MAY BE USED TO LOWER VEHICLE.

10. STREET STOCK MEANS STREET STOCK. ALL HOODS WILL BE OPENED BY TECH COMMITTEE OR TRACK JUDGE BEFORE THEY ARE ALLOWED TO PULL.
11. ALL TRUCKS ARE SUBJECT TO TECH COMMITTEE APPROVAL.
12. JUDGES OR TECHMEN DECISIONS WILL BE FINAL ON ANY POINT OF CONTROVERSY. ANY DISAGREEMENT WILL RESULT IN A DISQUALIFICATION.
13. MUST BE STATE LICENSED & INSPECTED.
14. POINT SERIES FOR THE STREET TRUCKS.
15. GAS STOCK 1 TON CLASS IF AVAILABLE. NO DIESEL.
16. NO SUPER CHARGERS

## **SUPER STREET STOCK DIESEL CLASS** *(Also Know as 2.5 Diesel)*

1. **8,500 LBS.** MAX WEIGHT
2. HITCH HEIGHT TO BE 20" MAX MUST BE REARWARD MOST POINT OF THE VEHICLE WITH A 3" WIDE BY 3.75" LONG OPENING. MUST BE REESE TYPE RECEIVER AND HITCH.
3. DOT APPROVED TIRES MAX SIZE IS 35" X 12.50 AS LABELED BY MANUFACTURER, NO CHAINS OR STUDS.
4. TRUCK MUST HAVE VALID REGISTRATION **AND PASSED INSPECTION.**
5. OEM DRIVELINE ONLY. THIS APPLIES TO FRONT AND REAR END HOUSINGS, TRANSMISSIONS, AND TRANSFER CASES. AFTER MARKET GEARS, LOCKERS, AXLES AND CV JOINTS ALLOWED.
6. VEHICLE IS LIMITED TO ONE TURBO 2.5" INDUCER BORE AND WILL BE CHECKED WITH A 2.55 SLUG. IT IS THE DRIVER'S RESPONSIBILITY TO PROVIDE ACCESS TO THE TURBO FOR THE TECH MAN
7. ALL TRUCKS LIMITED TO ONE (1) INJECTOR PUMP. LIFT PUMPS ALLOWED.
8. P-PUMPS ALLOWED ONLY ON VEHICLES PRE 1988. MUST BE STOCK APPEARING.
9. ANY OEM WHEEL BASE ALLOWED. NO MODIFICATIONS ALLOWED, MUST BE FACTORY.
10. DUAL REAR WHEELS NOT ALLOWED
11. DRIVE SHAFT HOOPS RECOMMENDED, OR CHAINS MANDATORY. MUST BE AT LEAST 5/16" CHAIN OR CABLE, NO NYLON STRAPS. 2 CHAINS OR CABLES PER SHAFT.
12. TRANSMISSION BLANKET RECOMMENDED
13. GUILLOTINE AIR SHUT-OFF RECOMMENDED

14. ALL WEIGHTS MUST BE IN BODY. NO ADDED WEIGHT IN CAB, UNDER THE HOOD, IN THE FRAME OR IN A BUMPER OR BULL PAR
15. ENGINE MUST BE FACTORY FOR THE VEHICLE AND BE IN OEM LOCATION
16. NO HAND THROTTLES ALLOWED
17. NO WATER AND/OR METHANOL INJECTION. NO NITROUS OR OXYGEN ENHANCING AGENTS. NO PROPANE. DIESEL FUEL ONLY. VEHICLES MAY BE CHECKED WITH A SNIFFER.
18. VEHICLES MUST RETAIN FACTORY SUSPENSION PARTS. BLOCKS ARE ALLOWED. LIFT KITS ALLOWED.
19. SLED STOPS RECOMMENDED
20. EXHAUST MUST EXIT UPWARD
21. AIR TO AIR INTERCOOLING ONLY. NO WATER TO AIR INTERCOOLERS
22. FUEL MAP ENHANCEMENT ALLOWED
23. A/M EXHAUST AND INTAKE ALLOWED

### **3.0 PRO STOCK DIESEL 4X4 TRUCK**

1. CLASS WILL RUN AT 8,000 POUNDS.  
**ALL MUST FOLLOW THE LUCAS OIL PRO PULLING CURRENT RULES. RULE BOOKS CAN BE PICKED UP FROM MSTTPA OFFICERS.**

### **4X4 AND 2X4 PRO-STOCK CLASS**

1. **ENGINE RULES**
  - a. MOTOR NOT TO EXCEED 406 CUBIC INCHES. (400 BORED .030 IVER.) NO G.M. BIG BLOCKS ALLOWED.
  - b. MUST RUN FLAT TOP PISTONS (NO DOME). TO BE CHECKED AT PLUG HOLE.
  - c. CAMS MAY NOT EXCEED .500 GROSS LIFT INTAKE AND EXHAUST MEASURED AT VALVE. CAM CHECK NOT CONSIDERED VISUAL.
  - d. FUELIE HEADS ALLOWED. HEADS MUST BE CAST IRON. NO ANGLE PLUGS. NO ROLLER CAMS. LIFTERS OR ROCKERS.
  - e. FACTORY CAST IRON DUAL INTAKE (DUAL PLANE). ALUMINUM DUAL PLANE INTAKE ON 351 & 400 M ONLY. SPACERS BETWEEN INTAKE & HEADS, OR SPACERS WELDED TO SAME NOT ALLOWED - ADAPTER 1/2 INCH THICK MAY BE USED TO ADAPT HOLLEY TO SPREAD BORE MANIFOLD IS ALLOWED. CARBURETOR SPACERS ARE NOT ALLOWED.

- f. CARBURETORS TO BE USED;
    - A. GM TRUCKS: ROCHESTER SPREAD BORE 4 BBL OR HOLLEY 3310-2,3,4,4 BBL DUAL FEED, SINGLE PUMP.
    - B. FORD TRUCKS: AUTOLIGHT MOTORCRAFT 4 BBL OR HOLLEY 331 0-2,3,4,4 BBL DUAL FEED, SINGLE PUMP.
    - C. DODGE TRUCKS: CARTER 4 BBL OR HOLLEY 3310-2,3,4,4 BBL DUAL FEED, SINGLE PUMP.
    - D. ALL CARBURETORS MUST HAVE AIR HORNS ON THEM
  - g. ANY TYPE OF TIMING ASSEMBLY ALLOWED.
  - h. FACTORY FUEL INJECTION ALLOWED. 1986 AND NEWER.
  - i. STOCK IGNITION ONLY, NO AFTER MARKET IGNITION.
2. HEADERS ALLOWED, MUST EXIT UNDER VEHICLE AND POINT STRAIGHT BACK.
  3. TIRES WILL BE ROAD INSPECTABLE AND STREET LEGAL 10" MAXIMUM TREAD WIDTH AT GROUND CONTACT, 16.5' MAXIMUM WHEEL ALLOWED. NO CUTTING OR GROOVING ALLOWED
  4. MINIMUM LENGTH OF DRAW-BAR 36% OF WHEELBASE, MEASURED FROM CENTER LINE OF REAR WHEELS.
  5. WEIGHT CLASSES TO BE 5500 LB. AND 6000 LB.
  6. SOLID REAR SUSPENSION ALLOWED.
  7. DIESELS WILL BE ALLOWED.
  8. ALL TRUCKS ARE SUBJECT TO TECH COMMITTEE APPROVAL.
  9. REAR WEIGHTS NOT TO EXCEED 60" FROM THE FURTHEST PART OF DIFFERENTIAL. FRONT WEIGHTS NOT TO EXCEED MORE THAN 60" FROM CENTER LINE OF FRONT AXLE.
  10. PRO-STOCK MUST HAVE HELMETS, DRIVE SHAFT SHIELDING, KILL SWITCHES AND METAL HUB SHIELDS.
  11. ELECTRIC WATER PUMPS AND FANS ALLOWED.
  12. ANY TYPE OF FUEL PUMP ALLOWED.

## **4X4 SUPER STOCK CLASS**

1. ENGINE IS LIMITED TO 500 CID, CAST IRON OR ALUMINUM HEADS. CAST IRON BLOCK ONLY. ENGINE AND TRANSMISSION TO REMAIN IN STOCK LOCATION.
2. BIG BLOCKS ALLOWED WITH RESTRICTIONS TO FOLLOW;
  - a. ANY SINGLE 4 BBL CARBURETOR WITH ANY INTAKE MANIFOLD MUST FIT UNDER HOOD.
  - b. NO AIM FUEL INJECTION ALLOWED.
3. ANY IGNITION MAY BE USED.



4. HEADERS OR OPEN EXHAUST WILL BE ALLOWED BUT MUST EXIT VERTICALLY, NOT ANGLED DOWN. NO HOOD ALTERATIONS OTHER THAN FOR EXHAUST AND FUEL SYSTEMS. FANS AND WATER PUMPS MUST BE SHIELDED 360 DEGREES WITH 1/16TH. STEEL OR .060 THICK ALUMINUM. ATTACHED WITH METAL BRACKETS, NOT ATTACHED TO FIBERGLASS SHROUDS. NO COMPUTER CONTROLS OF ANY KIND. HEADERS MUST POINT UPWARD THRU THE HOOD. NO EXCEPTION.
5.
  - a. AUTOMATIC TRANSMISSIONS TO BE USED, IT IS MANDATORY THE VEHICLE HAVE A SCATTER BLANKET. NTPA APPROVED, CHUTE TYPE BLANKET, 360 DEGREES AROUND TRANSMISSION.
  - b. STANDARD TRANSMISSIONS TO BE USED, IT IS MANDATORY A SEMA APPROVED FLY WHEEL, BELL HOUSING AND PRESSURE PLATE BE USED.
  - c. **OEM GEAR CASE (TRANSMISSION & TRANSFER) ALLOWED. AFTERMARKET GEARS ALLOWED.**
6. ANY STALL CONVERTER MAY BE USED. KILL SWITCHES ARE MANDATORY AND MUST BE IN WORKING ORDER AND MOUNTED IN CENTER OF BED ABOVE HITCH.
7. ORIGINAL WHEELBASE FOR THAT FACTORY PRODUCED 4X4 PICKUP.
8. ANY GEAR RATIO ALLOWED, THEREFORE, ANY DANA 60 OR 70 CORP. FRONT OR REAR ENDS MAY BE USED. MUST BE 1-1/2 TON OR SMALLER. MAY USE HARDENED AXLES.
9. HITCH HEIGHT FOR ALL SUPERSTOCK PICKUPS IS 24".
10. TIRE SIZE LIMITED TO 14" WIDE, 36" TALL. NO BAR-TYPE TIRES ALLOWED. 20" DIAMETER. NO CUTTING OR GROOVING ALLOWED.
11. WEIGHT CLASS TO BE 5800 LB. AND 6200 LB.
12. SOLID REAR SUSPENSION ALLOWED.
13. ALL TRUCKS WILL HAVE SF1 APPROVED HARMONIC BALANCER OR A SHIELD, 1/4" STEEL OR 3/8" ALUMINUM, TO COVER WIDTH OF BALANCER, WATER PUMP CAN BE PART OF SHIELD.
14. SEAT TO BE MOVED ANYWHERE IN CAB ENCLOSURE.
15. NO AFTERMARKET GEAR BOX ALLOWED (I.E. SCS OR PRO-FAB)
16. MAXIMUM 33 DEGREE ANGLE OF HITCH.
17. NO ALUMINUM BLOCKS ALLOWED.
18. NO TUBE TYPE CHASSIS ALLOWED, ONLY OEM MANUFACTURED ALLOWED.

## **4X4 MODIFIED CLASS**

1. ALL VEHICLES MUST COMPLY WITH CURRENT NTPA RULES. (SEE NTPA RULE BOOK) WITH THE FOLLOWING EXCEPTIONS:
  - a. ALL MAINE STATE PULLERS ASSOCIATION BYLAWS, GENERAL TRUCK RULES, 4X4 DISQUALIFICATION, 4X4 FUELS, 4X4 DRIVE SHAFT QUALIFICATIONS, SUPERSTOCK AND MODIFIED, OVER RIDE ANY RULE IN THE NTPA RULE BOOK.
  - b. ANY FACTORY PRODUCED STEEL OR FIBERGLASS BODIED VEHICLE, (MAXIMUM WHEELBASE 133”).
  - c. ALL VEHICLES MUST BE NATURALLY ASPIRATED WITH SINGLE ENGINES. NO DIESEL ENGINES
  - d. TINTED WINDOWS WILL BE ALLOWED AT TECHMEN'S DISCRETION. SEMA APPROVED FLYWHEEL, PRESSURE PLATE, & BELL HOUSING DOES NOT HAVE TO BE STAMPED BY NTPA, BUT WILL BE INSPECTED BY TECHMEN.
  - e. ANY ELIMINATOR SLED NEED NOT BE NTPA APPROVED.
  - f. 2 CLASSES WILL BE RUN AT 6,200 LBS EACH.
  - g. ALL TRUCKS AND TRACTORS USING ALCOHOL FUEL - IT IS MANDATORY TO WEAR A FIRE SUIT, CONSISTING OF A MINIMUM OF ONE (1) LAYER NOMEX 3 OR THE EQUIVALENT OF SF1 CERTIFICATION.
  - h. TRUCKS MAY USE APPROVED FULL TRANSMISSION BLANKET OR SF1 APPROVED BELL HOUSING AND TRANS BODY WITH BILLET ACCESS COVER.
  - i. ENGINES MUST COMPLY WITH ENGINE LIMITATIONS LISTED IN 1996 NTPA RULE BOOK. LIMIT TO 650 CU IN. 2 VALVES PER CYLINDER, 1 SPARK PLUG PER CYLINDER.
  - j. HITCH HEIGHT TO BE 26”

## **TWO WHEEL DRIVE RULES**

1. ALL GENERAL TRUCK RULES, FUEL RULES, AND HITCH RULES ARE THE SAME AS FOUR WHEEL DRIVE CLASSES.
2. DRIVE-SHAFT QUALIFICATIONS ARE THE SAME AS FOUR WHEEL DRIVE CLASSES EXCEPT THOSE RULES APPLYING TO SHAFTS NONEXISTENT ON TWO WHEEL DRIVES.

## **2X4 SUPERSTOCK CLASS RULES**

1. ENGINE LIMITED TO 500 CID, CAST IRON OR ALUMINUM HEADS, CAST IRON BLOCK ONLY. ENGINE AND TRANSMISSION TO REMAIN IN STOCK LOCATION. BIG BLOCKS ALLOWED WITH RESTRICTIONS TO FOLLOW: ANY SINGLE BBL CARB WITH ANY INTAKE, MANIFOLD TO FIT UNDER HOOD. NO A/M FUEL INJECTION

- ALLOWED.
2. ANY SINGLE 4 BBL CARBURETOR WITH ANY INTAKE MANIFOLD MUST FIT UNDER HOOD.
  3. ANY IGNITION CAN BE USED.
  4. HEADERS OR OPEN EXHAUST WILL BE ALLOWED BUT MUST EXIT UP OR BACK, NOT ANGLED DOWN, NO HOOD ALTERATIONS OTHER THAN EXHAUST AND FUEL SYSTEMS. FANS AND WATER PUMPS MUST BE SHIELDED 360 DEGREES WITH 1/16TH STEEL OR .060 THICK ALUMINUM, ATTACHED WITH METAL BRACKETS NOT ATTACHED TO FIBERGLASS SHROUDS.
  5.
    - A. TRANSMISSIONS MUST BE AUTOMOTIVE TYPE IN 2X4 PICKUPS. IF AN AUTOMATIC TRANSMISSIONS IS TO BE USED, IT IS MANDATORY THE VEHICLE HAVE A SCATTER BLANKET. NTPA APPROVED, CHUTE TYPE BLANKET, 360 DEGREES AROUND TRANSMISSION.
    - B. TRANSMISSION MUST BE AUTOMOTIVE TYPE AVAILABLE IN 2X4 PICKUPS. IF A STANDARD TRANSMISSION IS TO BE USED, IT IS MANDATORY A SEMA APPROVED FLY WHEEL, BELL HOUSING AND PRESSURE PLATE BE USED.
    - C. AFTER MARKET INTERNAL GEARS ALLOWED**
  6. ANY STALL CONVERTER MAY BE USED. KILL SWITCHES ARE MANDATORY AND MUST BE IN WORKING ORDER AND MOUNTED IN CENTER OF BED ABOVE HITCH.
  7. ORIGINAL WHEEL BASE FOR THAT FACTORY PRODUCED 2X4 PICKUP.
  8. ANY GEAR RATIO ALLOWED. THEREFORE, ANY DANA 60 OR 70 CORP FRONT OR REAR ENDS MAY BE USED. MUST BE 1-1/2 TON OR SMALLER. MAY USE HARDENED AXLES.
  9. HITCH HEIGHT FOR ALL SUPERSTOCK PICKUPS IS 26".
  10. TIRE SIZE LIMITED TO 14" WIDE, 36" TALL. NO BAR TYPE TIRES ALLOWED. 16.5 DIAMETER. NO CUTTING OR GROOVING ALLOWED.
  11. WEIGHT CLASS TO BE 5800 LB AND 6200 LB.
  12. SOLID REAR SUSPENSION ALLOWED.
  13. ALL TRUCKS WILL HAVE A SF1 APPROVED HARMONIC BALANCER OR SHIELD 1/4" STEEL OR 3/8" ALUMINUM TO COVER WIDTH CF BALANCER, WATER PUMP CAN BE PART OF SHIELD.
  14. SEAT TO BE STOCK FACTORY LOCATION ONLY.

## **2X4 MODIFIED**

1. 2X4 TO BE BUILT ACCORDING TO NTPA PULLING RULES WITH THE FOLLOWING EXCEPTIONS:
  - a. DIESEL ENGINES WILL BE ALLOWED WITH PROPER SHIELDING AND SAFETY REQUIREMENTS. A LIMIT OF 575 CU. IN. AND TWO VALVE PER CYLINDER.

- b. ALL TRUCKS MUST HAVE WORKABLE BRAKES FRONT & REAR.
- c. ALL TRUCKS AND TRACTORS USING ALCOHOL FUEL, IT IS MANDATORY TO WEAR A FIRE SUIT, CONSISTING OF A MINIMUM OF 1 LAYER NOMEMEX 3 OR THE EQUIVALENT OF SF1 CERTIFICATION.
- d. 2 CLASSES WILL BE RUN AT 6,200 LBS. EACH.
- e. HITCH QUALIFICATIONS SAME AS CURRENT NTPA RULES. HITCH HEIGHT TO BE 30".
- f. TRUCK MUST HAVE A PRESENTABLE VAN/PICKUP BED WITH COVER OR FLATBED IN PLACE.

## GENERAL FARM TRACTOR RULES

- 1. ALL TRACTORS EQUIPPED WITH A TURBOCHARGER SHALL BE REQUIRED TO HAVE AN EXHAUST PIPE THAT DISCHARGES VERTICAL. NO CURVED STACKS.
- 2. RAIN CAPS ARE NOT ALLOWED.
- 3. ANY TRACTOR WITH A TURBOCHARGER TO FOLLOW NTPA GUIDELINES FOR CROSS BOLTS IN THE EXHAUST

## STOCK FARM TRACTOR RULES & REGULATIONS

- 1. ALL TRACTORS TO BE STOCK AND CHECKED FOR RPM'S. GO STRICTLY BY ENGINE RPMS. 3000 RPM MAX FOR 4 & 6 CYLINDER, 3400 RPM MAX FOR V-8 CYLINDER.
  - A. IF ENGINE NEEDS TO BE REPLACED IT IS REPLACED WITH A OEM REPLACEMENT ENGINE WITH THAT MAKE & MODEL, NO FRAME ALTERATIONS.
- 2. CONTEST OPEN TO TRACTORS WITH RUBBER TIRES. NO 4 WHEEL DRIVES ALLOWED. NO DUAL TIRES, TIRE STUDS OR CHAINS PERMITTED. ALL POWER MUST BE TRANSMITTED THROUGH THE WHEELS.
- 3. DRIVERS 14 & 15 ALLOWED TO PULL IN STOCK CLASS WITH PARENTAL PERMISSION AND PASSING WITH CERTIFIED FARM TRACTOR COURSE WITH CERTIFICATE. DRIVERS 16 AND 17 YEARS OF AGE ARE PERMITTED TO PULL WITH PARENTAL PERMISSION. DRIVERS 18 YEARS OF AGE AND OLDER, PERMISSION IS NOT REQUIRED.
- 4. TIRE SIZES: 0-**10,500** LB. - 18.4 TIRE SIZE, **12,500** - 20,000 LB. - 20.8 TIRE SIZE. **NO ALUMINUM REAR WHEELS.**
- 5. ONLY 1 DRIVER MAY DRIVE SAME TRACTOR IN EACH CLASS.
- 6. DRIVER MUST NOT LEAVE SEAT OF TRACTOR WHILE PULLING.

7. WEIGHT OF TRACTOR SHALL INCLUDE THE DRIVER.
8. CHAIN MUST BE HOOKED TO THE FOLLOWING DRAW BAR SPECIFICATIONS. MINIMUM DRAW BAR LENGTH 18" FROM CENTER OF REAR WHEEL TO POINT OF HOOK. MEASURED HORIZONTALLY, DRAW BAR TO BE STATIONARY IN ALL DIRECTIONS. MAXIMUM HEIGHT OF 20' FROM TOP OF HITCHING DEVICE PERPENDICULAR TO GROUND. DRAW BAR MUST BE EQUIPPED WITH STEEL HITCHING DEVICE NOT MORE THAN 1" THICK, WITH 3" DIAMETER OPENING. CROSS-SECTIONAL THICKNESS MUST BE 7/8" MINIMUM. PULLING POINT MAY NOT BE MORE THAN 1-1/2" FROM BACK EDGE OF HITCHING DEVICE. NO SUPPORTS ATTACHED TO DRAW BAR.
  - a. DRAW-BARS TO BE RIGID WITH NO MOVEMENT ALLOWED WHEN READY TO HOOK TO SLED TO PULL. DRAW-BAR SPECIFICATIONS TO BE MINIMUM LENGTH OF 18" MEASURED HORIZONTALLY FROM CENTER OF REAR AXLE TO POINT OF HOOK. MAXIMUM HEIGHT TO BE 20" FROM THE TOP OF HITCHING DEVICE PERPENDICULAR TO GROUND. DRAW-BAR TO BE A STEEL HITCHING DEVICE NOT MORE THAN 1" THICKNESS, WITH A 3" DIAMETER OPENING, CROSS-SECTIONAL THICKNESS MUST BE A MINIMUM OF 7/8". PULLING POINT MAY NOT BE MORE THAN 1-1/2" FROM THE BACK EDGE OF HITCHING DEVICE. NO SUPPORTS ATTACHED TO DRAW-BAR.
9. CLASS WILL BE CANCELED IF NO ENTRIES IN WEIGHT CLASS.
10. NO PORTION OF TRACTOR MAY INTERFERE WITH SLED OR SLED HITCH DURING PULL.
11. ALL WEIGHT MUST BE SAFELY SECURED TO TRACTOR AND MUST NOT EXTEND REARWARD BEYOND REAR TIRES 6", NOR CAN WEIGHT EXTEND MORE THAN 13' FROM THE CENTER OF THE REAR AXLE TO THE FARTHEST POINT FORWARD. NO MOVABLE WEIGHT BRACKET ALLOWED BEFORE, DURING, OR AFTER. TRACTORS WILL NOT BE ALLOWED TO PULL WITH SUCH BRACKET EVEN IF IT'S UNHOOKED.
12. ALL TRACTORS MUST BE EQUIPPED WITH WORKABLE REAR WHEEL BRAKES.
13. ALL TRACTORS MUST HAVE A STRONG AND RIGID SEAT. ALL TIP SEATS MUST BE SECURELY FASTENED WHILE PULLING; SEATS WILL BE THOROUGHLY INSPECTED BY OFFICIALS.
14. THE USE OF STABILIZER BARS IS STRONGLY RECOMMENDED.
15. ALL TIRES WILL TURN IN CORRECT ROTATION.
16. IN CASE OF DISPUTE OR MISUNDERSTANDINGS, THE DECISION OF THE JUDGES OR SUPERINTENDENTS WILL BE CONSIDERED FAIR, IMPARTIAL AND FINAL.
17. THERE WILL BE NO OTHER CANS ON TRACTOR OR IN DRIVER'S POSSESSION WHILE ON THE PULLING TRACK OR HE WILL BE DISQUALIFIED. AIR TANKS DISCONNECTED.

18. ANY UNSPORTSMANLIKE CONDUCT WILL BE AN IMMEDIATE DISQUALIFICATION OF THE TRACTOR DRIVE & PIT CREW. ANY PURSES WON BY TRACTOR/DRIVER WILL BE RENEGED. THE TRACTOR/DRIVER MAY NOT BE ALLOWED TO PULL FOR THE CONTINUATION OF THE COMPETITION, AT THE DISCRETION OF THE JUDGES & OFFICIALS.
19. OBVIOUS CONSUMPTION OF ALCOHOLIC BEVERAGES WILL BE GROUNDS FOR DISQUALIFICATION & OR BARRED FROM COMPETITION.
20. CONTESTANTS MUST PULL AT POSITION DRAWN WITHIN 3 MINUTES OF TIME SLED IS AT READINESS; ANY DELAY WILL MEAN DISQUALIFICATION. IF PRESIDING JUDGE IS NOTIFIED HE MAY DROP A CONTESTANT HAVING MECHANICAL PROBLEMS 3 POSITIONS. THIS MAY BE DONE ONLY ONCE PER CONTESTANT PER CLASS.
21. JUDGES DECISION WILL BE FINAL ON ANY POINT OF CONTROVERSY; ANY DISAGREEMENT WILL RESULT IN DISQUALIFICATION.
22. EXCESSIVE OIL AND WATER LEAKS ARE SUBJECT TO DISQUALIFICATIONS.
23. ANY TRACTOR THAT LEAVES COURSE BOUNDARIES WILL BE DISQUALIFIED. FLAPS ARE NOT INCLUDED AS PART OF SLED.
24. STOCK FARM CLASSES TO BE: 6,000 LBS (60HP), 7,000 LBS (70HP), 8,500 LBS (80HP), 10,500 LBS, 12,500 LBS, 14,500 LBS, 16,500 LBS, 19,000 LBS. A CLASS NEEDS TO BE OFFERED A MINIMUM OF 2 TIMES DURING THE COMPETITION SEASON TO BE ELIGIBLE FOR YEAR END POINTS.
25. SIDE SHIELDS ARE RECOMMENDED, TO BE A MINIMUM THICKNESS OF .060".
26. NO ELECTRONICALLY CONTROLLED ENGINES, INCLUDES NO COMPUTERS (LAPTOP)
27. **12,500 LBS UP TO 22,000 LBS. TIE BARS, ENGINE, REAR END**

### **SUPER FARM TRACTORS - 9,300 LBS.**

1. ALL TRACTORS MUST COMPLY WITH NTPA RULES CERTIFICATION REQUIREMENTS. EQUIPMENT CURRENTLY BEING COMPETED MUST MEET NTPA SPECIFICATIONS & RULES BY 2011 (NO GRAND-FATHER CLAUSES).
2. A/M OR FABRICATED EXHAUST MANIFOLDS AND RAM AIR ALLOWED

### **SUPERSTOCK TRACTORS**

1. SUPERSTOCK TRACTORS WILL PULL ACCORDING TO NATIONAL RULES IN WEIGHT AND CLASS.

### **MODIFIED**

1. MODIFIED TRACTORS WILL PULL ACCORDING TO NATIONAL RULES IN BOTH WEIGHT AND CLASS.

## **PROSTOCK TRACTORS**

1. VEHICLES MUST COMPLY WITH NTPA RULES & CERTIFICATION REQUIREMENTS BY NO LATER THAN 2011. (NO GRANDFATHER CLAUSES)

## **PROFARM TRACTORS**

1. THE DIVISION WILL RUN AT 8,500 LBS.
2. SAFETY
  - A. NO RIDERS AT ANY TIME
  - B. 2.5 LB. FIRE EXTINGUISHER WITHIN REACH OF DRIVER REQUIRED.
  - C. DRAW-BARS TO BE STATIONARY IN ALL DIRECTIONS.
  - D. WEIGHTS WILL NOT INTERFERE WITH SLED OR CHAIN
  - E. ALL VEHICLES TO HAVE "WHEELIE BARS"
    1. STABILIZER TO BE A MINIMUM OF 32" FROM CENTER OF REAR AXLE TO REAR MOST POINT
    2. MINIMUM WIDTH 20" FROM OUTSIDE OF PADS
    3. PADS NOT TO EXCEED 10" OFF THE GROUND
    4. PADS TO BE A MINIMUM OF 5" SQUARE
    5. STABILIZER ASSEMBLY MUST SUPPORT WEIGHT OF THE TRACTOR IN THE HEAVIEST CLASS PULLED.
  - F. AIR SHUT OFF MUST BE CABLE OPERATED MANDATORY GUILLOTINE TYPE. CABLE MUST BE LOCATED 4 FEET ABOVE THE POINT OF HOOK AND WITHIN 6 INCHES OF THE CENTER OF THE TRACTOR, AND HAVE A 2 INCH RING IN CLEAR VIEW.
  - G. DEAD MAN THROTTLE REQUIRED, DUAL RETURN SPRINGS.
  - H. SIDE SHIELDS OF ALUMINUM OR STEEL REQUIRED, MINIMUM THICKNESS OF 0.060"
  - I. HELMETS AND FIRE SUITS MANDATORY IN PRO FARM CLASS
  - J. MANDATORY THAT TRACTORS HAVE A 3 BAR ROLL CAGE TO MEET SFI 47.1.
  - K. STEEL FLYWHEEL RECOMMENDED, SCATTER BLANKET, OR STEEL SHIELDS REQUIRED.
3. ENGINES
  - a. BLOCK TO BE SAME AS ORIGINAL MANUFACTURER
  - b. MUST BOLT TO FACTORY BELL HOUSING

- c. MAXIMUM DISPLACEMENT: 410 CID-8,500#. PLUS OR MINUS 1%
  - d. **WATER INJECTION, OR COOLING OF TURBOS IS ALLOWED**
  - e. TURBOS: ONE 3" IN/3" OUT
  - f. 13MM P-PUMPS MAX
  - g. DIESEL OR GASOLINE ONLY, NO ALCOHOL
  - h. HEAD TO BE SAME MANUFACTURER AS ENGINE BLOCK, NO AFTER MARKET HEADS ALLOWED. 24 VALVE HEAD ALLOWED.
4. TIRES
- a. MAXIMUM SIZE:  
8,500# 18.4
  - b. NO LIMIT ON RIM WIDTH
  - c. RADIALS ALLOWED
  - d. NO PROFESSIONAL PULLING TIRES OF ANY SORT ARE ALLOWED
5. DRAW BAR
- a. DRAW BARS MUST NOT EXCEED 20 INCHES IN HEIGHT OR LESS THAN 18 INCHES FROM CENTER OF THE AXLE TO HOOKING POINT. NO PART OF THE DRAW BAR MAY EXTEND REARWARD BEYOND POINT OF HOOK. DRAW BARS ARE TO BE STATIONARY IN ALL DIRECTIONS. NO CLEVIS.
6. THESE RULES SHALL BE MAINTAINED FOR (3) THREE YEARS WITH NO RULE CHANGES, UNLESS 75% OF THE ACTUAL PULLERS OF THE CLASS AGREE TO & SIGN OFF ON A CHANGE. THE ATTEMPT IS TO ALLOW PEOPLE TO BUILD FOR THE CLASS AND KNOW THAT IT WILL BE THE SAME RULES FOR AT LEAST THE NEXT THREE YEARS.

## **MINI RULES GENERAL**

- 1. MODIFIED MINI TRACTORS ARE DEFINED AS ANY TRACTOR WITH OUT STANDARD BLOCK OR CRANKCASE FOR MAKE AND MODEL OF CHASSIS IN WHICH ENGINE IS MOUNTED.
- 2. NO PORTION OF ANY TRACTOR MAY EXCEEDS' FORWARD OF THE CENTER OF THE REAR WHEEL.
- 3. NO PORTION OF ANY TRACTOR SHALL EXCEED 6' IN WIDTH.
- 4. AFTERMARKET TRANSMISSIONS ARE ALLOWED.
- 5. WEIGHT CLASSES TO BE 1650 LB. & 1800 LB.
- 6. V-8 MINI MODIFIED REAR ENDS ARE TO BE AS MASS PRODUCED BY OEM MANUFACTURERS. (I.E. FORD, GM OR DODGE) AS FOUND IN PASSENGER CARS OR LIGHT DUTY TRUCKS. MUST BE ABLE TO ACCEPT OEM CENTER SECTIONS. MAY BE ALUMINUM OF OEM OR TO OEM SPECS AND LIKENESSES. NO AFTERMARKET WILL BE ALLOWED OF PLANETARY VERSIONS OR PLANETARY TYPE.



## **CHASSIS**

1. ALL TRACTORS SHALL HAVE WIDE FRONT AXLES. FRONT WHEELS SHALL TRACK WITHIN THE REAR WHEELS.

## **ENGINES**

1. V-8 MINI MODIFIED TRACTORS WILL BE NATURALLY ASPIRATED. MAXIMUM CUBIC INCHES TO BE 410 CI. SINGLE ENGINE ONLY, WITH ONLY TWO (2) VALVES PER CYLINDER AND ONE (1) SPARK PLUG PER CYLINDER. NO BIG BLOCKS OR HEMIS ALLOWED. NO ALUMINUM BLOCKS ALLOWED.
2. A DEFLECTION SHIELD IS REQUIRED ON BOTH SIDES OF ALL ENGINES. SHIELD MUST EXTEND THE COMPLETE LENGTH OF BLOCK CASTING AND BE SECURELY FASTENED. IT IS TO BE MADE OF ALUMINUM OR STEEL A MINIMUM OF .060" THICK OR SAFETY BLANKET MATERIAL. SHIELDS MUST BE SOLID MOTOR MOUNTS, FILTERS, STEERING RODS, ETC., CANNOT SERVE AS PART OF SHIELD, PROVIDING IT COVERS REQUIRED AREAS OF BLOCK CASTING. IT IS RECOMMENDED THAT A QUICK RELEASE FASTENER BE USED.
3. STARTER MOTORS, FUEL FILTERS, OIL FILTERS AND FUEL INJECTION PUMPS MAY NOT BE USED AS SHIELDING. SHIELDING MAY COVER OR PASS BEHIND STARTER OR FUEL PUMP.
4. SHIELDING MUST EXTEND FROM BASE OF HEAD OR THE UPPER-MOST POINT OF PISTON, TRAVEL TO 2" BELOW BOTTOM CENTER OF CRANKSHAFT THROW, AND BE SECURELY FASTENED.
5. SIDE SHIELDS MUST BE MOUNTED INDEPENDENTLY OF THE ENGINE BLOCK. MOTOR MOUNT, BLOCK SAVER PLATE AND HEADER MOUNTING OR CHASSIS MOUNTING IS ACCEPTABLE.
6. ALL BLOW-BY TUBES MUST EXIT FORWARD OF REAR TIRES. ENGINE CRANK VENTING: ALL ENGINE CRANK CASE VENTING BLOW-BY TUBE MUST BE VENTED BELOW THE HEAD OF THE ENGINE AND EXTEND DOWN TO THE ENGINE PAN.
7. ALL VEHICLES MUST BE EQUIPPED WITH A DEADMAN THROTTLE, ALL THROTTLES WORKING IN A FORWARD-REARWARD DIRECTION, THROTTLES SHALL BE CLOSED IN THE REAR MOST POSITION. NO HYDRAULIC THROTTLES ALLOWED. ALL THROTTLES MUST HAVE DUAL RETURN SPRINGS TO THE CLOSED POSITION. ALL FOOT THROTTLES TO HAVE A TOE STRAP.
8. HARMONIC BALANCERS; ALL AUTOMOTIVE ENGINES EQUIPPED WITH A HARMONIC BALANCER: BALANCER SHALL BE SOLID STEEL OR BE SF1 CERTIFIED.
9. A BOLT IN THE CRANKSHAFT TO HOLD DAMPER PULLEY IS REQUIRED.
10. ALL ENGINE FANS MUST BE SHROUDED WITH STEEL 1/16" OR THICKER, 360° DEG.

## **EXHAUST SYSTEMS**

1. ALL EXHAUST MUST DISCHARGE VERTICALLY. HEIGHT TO BE A MINIMUM OF ONE FOOT ABOVE THE BEND IN THE PIPE WHICH DISCHARGES VERTICALLY MEASURED FROM TOP OF THE PIPE TO BOTTOM OF BEND. ALL EXHAUST PIPES MUST BE SECURELY ATTACHED, VERTICAL PS DEFINED AS BEING WITHIN 10 DEGREES, IN ANY DIRECTION OF BEING PLUMB. RAIN CAPS MAY NOT BE USED. NO MEGAPHONE PIPES ALLOWED.

## **FUEL AND FUEL CONTAINERS**

1. ALL FORMS OF NITROMETHANE (INCLUDING NITROUS OXIDE) ARE ILLEGAL AS A FUEL OR FUEL ADDITIVE FOR PULLING. LEGAL FUELS ARE ALCOHOL, WATER, DIESEL FUEL, AVIATION GAS, GASOLINE, PROPANE GAS, NO OXYGEN CARRIERS AND COMBUSTION ACCELERATORS.
2. NO PRESSURIZED FUELS ALLOWED EXCEPT IN UL. APPROVED PRESSURE TANKS. NO OXYGEN ALLOWED.

## **KILL SWITCHES**

1. ALL KILL SWITCHES MUST BE MOUNTED INDEPENDENT OF THE DRAW BAR AND OR WHEELIE BARS.
2. ALL PULLING VEHICLES MUST HAVE AN AUTOMATIC IGNITION KILL SWITCH, IN WORKING ORDER AT ALL TIMES. TRACK OFFICIALS HAVE THE OPTION OF CHECKING KILL SWITCHES AS MANY TIMES AS THEY FEEL IS ADEQUATE AT ANY EVENT. SWITCHES MUST BE CHECKED WITH ENGINE RUNNING.
3. KILL SWITCH MUST BE IN REAR CENTER (MAXIMUM OF 6" OFF CENTER IN ANY DIRECTION), 18" ABOVE THE POINT OF HOOK.
4. ON A SPARK IGNITION ENGINE, THE KILL SWITCH MUST BREAK OR GROUND THE IGNITION CIRCUIT. ON VEHICLES EQUIPPED WITH SPARK IGNITION CIRCUIT. ON VEHICLES EQUIPPED WITH SPARK IGNITION ENGINES AND ELECTRIC FUEL PUMPS THE KILL SWITCH MUST ALSO BREAK CURRENT TO THE FUEL PUMP.
5. THE BREAK AWAY KILL SWITCHES MUST HAVE ATTACHED TO THEM A MINIMUM OF A 2" DIAMETER RING. THE CABLE FROM THE SLED WILL BE ATTACHED TO THIS RING.
6. PORTION OF THE KILL SWITCH AND MOUNTING BRACKETS MUST BE ABLE TO STAND 32 POUNDS OF PULL PER SWITCH WHEN PULLED INDEPENDENTLY OR COLLECTIVELY.
7. KILL SWITCH RING MUST BE SECURED WITH A NYLON TIE WRAP 1/8". THIS WRAP MUST BE BROKEN FOR ARE-PULL.
8. IF VEHICLE HAS KILL SWITCH OR SHUTOFF LOCATED IN LEGAL POSITION AND DURING THE PULL IT IS PULLED AND NYLON STRAP BROKEN, AND THE PRESIDING JUDGE INSPECTS AND FINDS SWITCH CAPABLE OF OPERATING PROPERLY UNDER NORMAL CONDITIONS, VEHICLE WILL BE ALLOWED TO RE-PULL IMMEDIATELY OR DROP SIX POSITIONS. DECISION TO DROP MUST BE MADE BEFORE VEHICLE LEAVES THE TRACK. IT IS THE PULLER'S RESPONSIBILITY TO SEE THAT THE SWITCH IS CHECKED BY THE OFFICIAL BEFORE LEAVING THE TRACK.

9. ALL IGNITION ENGINES MUST HAVE BAR TYPE MASTER SHUTOFF SWITCH FOR ALL MOTORS IN WORKING ORDER WITHIN EASY REACH OF DRIVER.

## **SAFETY**

1. IF PRESIDING OFFICIAL AND TECH OFFICIAL FEEL A VEHICLE IS UNSAFE, THEY HAVE THE RIGHT NOT TO ALLOW VEHICLE TO PULL.
2. ALL PULLING VEHICLES, MUST BE EQUIPPED WITH A MINIMUM OF 2 LB HALON TYPE FIRE EXTINGUISHER, FULLY CHARGED, IN WORKING CONDITION AND CONVENIENT TO OPERATOR.
3. ALL DRIVERS MUST WEAR HELMETS. ALL HELMETS MUST HAVE CHIN STRAP FASTENED WHILE PULLING. HELMETS MUST MEET OR EXCEED SNELL 85 RATING OR MUST BE SF1 SPEC .312. NO MODIFICATIONS OR ALTERATIONS ALLOWED.
4. ALL TRUCKS AND TRACTORS USING ALCOHOL FUEL IT IS MANDATORY TO WEAR A FIRE SUIT, CONSISTING OF A MINIMUM OF ONE (1) LAYER NOMEX 3 OR THE EQUIVALENT OF SF1 CERTIFICATION.
5. COMPETING CARD HOLDER MUST BE SEATED IN OR ON THE VEHICLE WHEN HIS/HER ENGINE OR ENGINES ARE BEING STARTED AND RUNNING & HAVE COMPLETE CONTROLS OF THE VEHICLE AT ALL TIMES. ONLY WHEN THE VEHICLE IS HOOKED TO THE SLED CAN THE DRIVER LEAVE THE SEAT WITH THE ENGINE RUNNING.
6. A REVERSE SAFETY LIGHT SYSTEM IS REQUIRED ON ALL TRACTORS. A WHITE LIGHT AUTOMOTIVE QUALITY MINIMUM 2" IN DIAMETER, MUST BE MOUNTED DIRECTLY ABOVE OR BELOW THE SAFETY KILL SWITCH AT THE REAR OF THE TRACTOR. A LIGHT IN THE DRIVER'S COMPARTMENT MUST BE OPERATED OFF THE SAME SYSTEM. BOTH LIGHTS ARE TO BE ACTIVATED BY A SHIFT LEVER SUCH THAT IT WILL BE LIT ONLY WHEN THE VEHICLE IS IN REVERSE.
7. ALL PULLING VEHICLES MUST BE EQUIPPED WITH A STARTER INTERRUPTER SWITCH ON THE GEARSHIFT WHICH WILL ALLOW STARTER ENGAGEMENT ONLY IN A NEUTRAL GEARSHIFT POSITION.

## **SEATS AND FENCERS**

1. ALL SEATS MUST HAVE NO MORE THAN 2" BEHIND REAR OF SEAT. A SUBSTANTIAL BACKREST MADE OF 1/2" CROSS SECTION OF STEEL OR METAL EQUAL IN STRENGTH WITH A MINIMUM 4" WIDE AND 6" LONG PAD FIRMLY ATTACHED; OR A MANUFACTURED SEAT EQUAL IN STRENGTH.
2. FENDERS TO CONSIST OF BARRIER BETWEEN DRIVER AND TIRE FENDER TO BE A MINIMUM OF 1" OVER HEIGHT OF TIRE, FENDER TO CURL 4" HORIZONTALLY FROM VERTICAL EDGE OVER THE TIRE, IN THE SAME CONFIGURATION AS THE TIRE. MINIMUM LENGTH OF 18" AT THE TOP OF THE FENDER. MUST BE ABLE TO SUPPORT THE WEIGHT OF THE DRIVER. FENDERS OR TIRE SHIELDS MUST BE CONSTRUCTED SO THAT WHEN THE DRIVER IS SEATED AND THE HANDS ARE ON THE WHEEL, HE CANNOT TOUCH THE REAR TIRE WITH ANY PART OF HIS BODY.

3. WHEELS OR SKID PADS TO BE A MINIMUM OF 1/2 THE TIRE DIAMETER LENGTH WHEN MEASURED FROM REAR AXLE CENTER LINE TO REAR OF PAD. PAD TO BE 6" (MAXIMUM) ABOVE GROUND. ONE SKID PAD OR WHEELS TO BE ON EACH SIDE OF THE TRACTOR, THE COMBINATION STRONG ENOUGH TO SUPPORT THE WEIGHT OF THE TRACTOR.

## **TIRES**

1. NO DUAL TIRES, TIRE STUDS OR CHAINS PERMITTED. ALL POWER MUST BE TRANSMITTED THROUGH THE WHEELS.
2. RIM SIZE TO BE 16" DIAMETER, MAXIMUM WIDTH OF LUGS TO BE NO WIDER THAN THAT OF FACTORY MANUFACTURED 18.4X16.1 TIRES. NO TIRE REPAIRS (BOOTS, SECTION REPAIR, VULCANIZED SPOTS, ETC. TO BE ALLOWED.

## **CLUTCHES, FLYWHEELS & AUTOMATICS**

1. THE USE OF TORQUE CONVERTERS, AUTOMATIC SHIFTS, ETC., WILL BE PERMITTED.
2. ALL AUTO TRANSMISSIONS AND TORQUE CONVERTERS WILL BE COVERED WITH A BLANKET MEETING CURRENT SF1 SPECIFICATIONS OR 2 BLANKETS MEETING SEMA APPROVED SPECIFICATIONS. BLANKET IS TO EXTEND FROM REAR OF ENGINE BLOCK TO FRONT OF TAIL HOUSING. BLANKET MUST BE FASTENED FORWARD SECURELY W/2 STRAPS ON EACH SIDE, 1" ABOVE CRANK-SHAFT CENTER LINE & 1" BELOW CRANKSHAFT CENTER LINE. BLANKET SHOULD HAVE 6" OF OVERLAP. STRAPS MUST BE 2" WIDE W/ NOT MORE THAN 1" SPACING BETWEEN EACH STRAP
3. ALL PULLING VEHICLES USING AN AUTO TRANSMISSION MUST BE EQUIPPED WITH A POSITIVE REVERSE GEAR LOCKOUT.
4. ALL PULLING VEHICLES USING A CLUTCH WILL BE REQUIRED TO HAVE A SF1 APPROVED STEEL PLATE OR STEEL BILLET FLYWHEEL.
5. NO LIGHTENING HOLES ALLOWED ON THE TRANSMISSION FACE OF THE BELL HOUSING. ONE COOLING HOLE ALLOWED, MAXIMUM 1" IN DIAMETER ON THE FACE OF THE BELL HOUSING. BELL HOUSING MAY NOT BE WELDED UP AND REUSED.
6. NO CHEMICAL MILLING ALLOWED.
7. THERE SHALL BE TWELVE 5/16" GRADE 5 OR BETTER CAP SCREWS SECURING THE COVER TO THE BELL HOUSING. THE COVER MUST HAVE A PLATE OR FILLET THAT FITS FLUSH INSIDE OF THE HOUSING. THE COVER AND FILLET MUST BE STEEL. THE FILLET MUST BE WELDED TO THE COVER AND ALL BOLTS MUST BE FLUSH TO THE INSIDE.
8. THERE MUST BE FOUR BOLTS USED TO SECURE THE TRANSMISSION TO THE BELL HOUSING, 1/2" MINIMUM DIAMETER.
9. ALL BELL HOUSINGS MUST BE FLUSH ON THE INSIDE SURFACE.
10. ALL AUTOMOTIVE TYPE ENGINES WITH BELL HOUSING AND CLUTCH WILL RUN A FULL LOCK PLATE. EITHER A COMMERCIALY AVAILABLE UNIT, OR MINIMUM 3/16" STEEL OR 1/4" ALUMINUM WITH FIVE 3/8" GRADE S BOLTS EVENLY SPACED ON THE BOTTOM OF THE BELL HOUSING.

## **STABILIZER BARS**

1. STABILIZER BAR SYSTEM MUST BE ABLE TO SUPPORT THE WEIGHT OF THE TRACTOR IN THE HEAVIEST CLASS PULLED.
2. STABILIZER BARS ARE REQUIRED. THE DRAW BAR & DRAW BAR ASSEMBLY WILL NOT IN ANY WAY BE ATTACHED TO STABILIZER BAR ASSEMBLY. DEVICE IS TO HAVE WHEELS OR A SKID PLATE. WHEELS ARE TO BE AT LEAST 1" WIDE & 8" IN DIAMETER. SKID PADS TO BE AT LEAST 4" SQUARE AT GROUND CONTACT POINT.

## **DRIVELINE SHIELDING**

1. ALL REMAINING DRIVE TRAIN, EXCLUDING ANY ADDITIONAL MANUAL TRANSMISSIONS, MUST BE ENCLOSED IN 5/16" MINIMUM STEEL OR 3/8" ALUMINUM, ROUND, INSIDE DIAMETER NOT TO EXCEED 2" MORE THAN THE OUTSIDE DIAMETER OF THE LARGEST UNIVERSAL JOINT, FASTENED EVERY 6" OR CLOSER, WITH 3/8" OR LARGER BOLTS, GRADE 5, OR BUTT AND SEAM WELDED, AND SECURELY MOUNTED TO VEHICLES FRAME. APPLIES TO ALL VEHICLES WITH EXPOSED DRIVE SHAFT. NO MORE THAN 1/4" OF END OF DRIVELINE SHALL BE VISIBLE WITH DRIVELINE SHIELDING IN PLACE. NOTE: IF U-JOINTS ARE USED IN ANY DRIVE SHAFT APPLICATION, THE SHIELDING MUST BE 5/16" STEEL OR 3/8" ALUMINUM WITH 1/8" STEEL INSERT IN ALUMINUM. THE INSERT MUST BE A MINIMUM OF 6" WIDE.
2. THE OPENING AT THE BOTTOM OF THE TRANSMISSION/TORQUE CONVERTER HOUSING MUST BE ENCLOSED IN STEEL (STOCK COVER IS ACCEPTABLE).
3. ALL MINI TRACTOR ENGINE/AUTOMATIC TRANSMISSIONS COMBINATIONS MUST HAVE TWO FRONT MOTOR MOUNTS, TWO REAR MOTOR MOUNTS AND A SUPPORT SADDLE FOR REAR OF TRANSMISSION, WITH 1/2" MAXIMUM CLEARANCE; OR
4. TWO FRONT MOTOR MOUNTS, SUPPORT SADDLE AT REAR OF ENGINE WITH 1/2" CLEARANCE AND A MOUNT AT REAR OF TRANSMISSION. THIS IS TO PREVENT ENGINE OR TRANSMISSIONS FROM DROPPING IF BREAKAGE OCCURS.

## **BRAKES**

1. ALL COMPETING VEHICLES MUST BE EQUIPPED WITH WORKING REAR WHEEL BRAKES.
2. ALL DRIVELINE MUST HAVE 3/8" STEEL, 360 DEGREES AROUND BRAKE COMPONENTS, AND ENDS MUST BE CLOSED WITH 1/8" STEEL OR GREATER.

## **DRAW BAR**

1. DRAW BARS CANNOT BE SHORTER NOR HIGHER THAN SPECIFICATIONS LISTED BELOW. DRAW BAR LENGTHS ARE MEASURED FROM THE CENTER OF THE REAR WHEELS TO THE POINT OF HOOK.
  - a. DRAW BAR HEIGHT 13".
  - b. DRAW BAR LENGTH 6".

2. DRAW BARS TO BE RIGID, WITH NO MOVEMENT ALLOWED. DRAW BARS MUST HAVE THE PIVOT PIN ON THE SAME PLANE AS THE HITCH POINT AND TO THE GROUND WITHIN 1-1/2 INCHES, PLUS OR MINUS, PER FOOT OF LENGTH. THIS FORMULA TRANSLATES TO A LEGALLY ALLOWED 10 DEGREES OR LESS OF THE DRAW BAR ANGLE.
3. ALL DRAW BARS AND HITCHING DEVICES WILL BE STEEL.
4. MINI DRAW BAR AND HITCHING DEVICE TO BE ONE PIECE TOTALLY CONSTRUCTED WITH MINIMUM OF 1 INCH SOLID STEEL MATERIAL. NO HOLLOW TUBING IS PERMITTED. FRONT POINT OF DRAW BAR IS TO HAVE A MINIMUM OF 1/2 INCH CROSS SECTIONAL THICKNESS REMAINING WHERE HOLE IS DRILLED. MINIMUM 1/2 INCH PIN. DRAW BAR HEIGHT ADJUSTING BOLTS TO BE 5 INCHES OR LESS FROM HOOKING POINT THE FRONT POINT OF HOOK IS TO HAVE A MINIMUM OF A 2 INCH ROUND HOLE, MAXIMUM 2-1/4 HOLE. THE THICKNESS OF MATERIAL AROUND THE HOLE MUST BE A MINIMUM 3/4 INCH THICK AND POINT OF HOOK TO BE NO MORE THAN 3/4 INCH CROSS SECTIONAL THICKNESS AT BACK EDGE.

THE FOLLOWING MAY BE USED INSTEAD OF 4.

MINI TRACTOR DRAW BARS MUST BE EQUIPPED WITH A HITCHING DEVICE 3/4" THICK AND MUST HAVE A MIN. 2" ROUND HOLE. PULLING POINT MUST BE 3/4" FROM BACK EDGE OF HITCHING DEVICE CROSS SECTIONAL THICKNESS OF 3/4" SQUARE STEEL OR 7/8" ROUND WITH A 1/2" STEEL PIN. DRAW BAR HEIGHT ADJUSTING BOLTS TO BE 5" OR LESS FROM THE HOOKING POINT. ALL MINI TRACTORS WILL BE REQUIRED TO HAVE A DRAW BAR RESTRAINT CABLE CONSISTING OF A MIN. OF 1/2" ALL STEEL CABLE AND 2, 1/2" CLAMPS TO JOIN CABLE TOGETHER. CABLE TO GO AROUND FURTHER MOST BACK POINT OF HITCHING DEVICE & GO AROUND AXLE TIRES AND OVER REAR END HOUSING AND BE JOINED WITH 2, 1/2" CABLE CLAWS. CABLE TO BE INSTALLED AS TIGHTLY AS POSSIBLE TO PREVENT A SUDDEN JERK IF DRAW BAR BREAKS. CABLE MAY BE HELD UP AROUND BACK OF HITCHING DEVICE WITH PLASTIC CABLE TIES IN SUCH A MANNER AS NOT TO INTERFERE WITH THE SLED HOOK WHEN BEING HOOKED UP.

5. NO PORTION OF VEHICLE MAY INTERFERE WITH SLED, CHAIN OR HOOK DURING A PULL OR WHILE BEING HOOKED OR UNHOOKED.
6. AREAS 6" WIDE AND 12" HIGH IMMEDIATELY ABOVE THE DRAW BAR MUST BE FREE OF ALL OBSTRUCTIONS (INCLUDING WEIGHTS, WHEELIE BARS) FOR EASE OF HOOKING AND UNHOOKING.
7. DRAW BARS TO HAVE NO PROVISIONS TO BE MADE SHORTER THAN THE LEGAL LENGTH.
8. DRAW BARS AND WHEELIE BARS ARE NOT TO BE CONNECTED
9. NO TRICK HITCHES, NO CAM TYPE REAR ENDS. DRAW BAR DISTANCE FROM CENTER OF REAR AXLE CANNOT CHANGE DURING PULL, DRAW BAR MUST BE RIGID IN ALL DIRECTIONS.
10. ALL VEHICLES ARE REQUIRED TO HAVE A TOW HITCH ON THE FRONT OF THEIR VEHICLE.

## **MINI MODIFIED ADDING WEIGHTS**

1. WEIGHTS MUST BE SECURELY FASTENED.
2. NO TRANSFER OF WEIGHTS WHILE VEHICLE IS IN MOTION WILL BE ALLOWED.
3. WEIGHTS MUST NOT EXTEND REARWARD BEYOND THE REAR TIRES.
4. ANY BALLAST LOST WHILE HOOKED TO THE SLED AND UNDER THE GREEN FLAG WILL BE CAUSE FOR DISQUALIFICATION. A WEIGHT TOUCHING THE GROUND, ALTHOUGH IT MAY STILL BE ATTACHED TO THE PULLING VEHICLE, WILL BE CAUSE FOR DISQUALIFICATION (INTERNAL BREAK AGE EXCEPTED).
5. WEIGHT MUST NOT INTERFERE WITH THE KILL SWITCH, DRAW BAR, OR CHAIN.

## **SF1**

1. ALL TRACTORS WILL USE A ONE PIECE SOLID STEEL HARMONIC BALANCER OR AN SF1 APPROVED UNIT.
2. ALL TRACTORS USING A FLYWHEEL WILL USE A STEEL BILLET UNIT OR A SF1 APPROVED UNIT.
3. ALL FIRE SUITS WILL MEET SF1 SPECS.
4. ALL CLUTCHES AND PRESSURE PLATES WILL MEET SF1 SPECS OR A BLANKET MEETING SEMA OR NHRA SPECS WILL BE USED OVER A SAFETY BELL HOUSING MEETING SF1 SPEC 6.1.
5. ALL TRACTORS USING STANDARD TRANSMISSIONS WILL USE A BELL HOUSING MEETING SF1 SPEC 6.1. A BLOCK SAVER PLATE OF 3/16 STEEL OR 1/4 ALUMINUM WILL BE USED ON BOTTOM 1/2 OF BELL HOUSING. IF NO CLUTCH PEDAL IS USED THIS AREA WILL BE FILLED IN WITH A FILLIT OF THE SAME MATERIAL & THICKNESS THAT THE BELL HOUSING IS MADE OF. THE FILLIT WILL BE BOLTED IN WITH A MINIMUM OF (5) 5/16 GRADE 5 BOLTS. THE BELL HOUSING CANNOT BE ALTERED FROM ORIGINAL MANUFACTURER. IF CLUTCH PEDAL IS USED A SHIELD WILL BE USED TO ENCLOSE THIS AREA TO KEEP ANY MATERIAL FROM COMING OUT. THIS WILL BE OF 5/16 STEEL OR 3/8 ALUMINUM.

## **GENERAL RULES FOR LAWN & GARDEN, NON-AUTOMOTIVE, 4 CYL, V8 MINIS**

1. ALL PULLS WILL BE ON A SOIL SURFACE.
2. WIDTH OF TRACK TO BE 12' MINIMUM AND LENGTH TO BE 100' MINIMUM AND MAXIMUM OF 300' UNLESS FLOATING FINISH IS USED. SHUT DOWN TO BE DETERMINED UPON LENGTH OF TRACK AND IT WILL BE MARKED.
3. NO ONE WILL BE ALLOWED ON THE TRACK DURING PULLING EXCEPT TRACK CREW, SAFETY-TECH DIRECTORS AND IN THE LAWN & GARDEN CLASS A PARENT OR GUARDIAN IS ALLOWED BUT CAN'T TOUCH TRACTOR WHEN THE TRACTOR IS PULLING.

4. NO WEIGHTS SHALL INTERFERE WITH HITCHING TO THE DRAG. ALL WEIGHTS, SEATS MUST NOT MOVE WHEN UNDER THE GREEN FLAG AND IF IT DOES YOU WILL BE DISQUALIFIED.
5. A PULL MUST START FROM A TIGHT HITCH - NO JERKING.
6. DRIVER'S MUST REMAIN IN THE SEAT AT ALL TIMES AND NO BOUNCING. DRIVERS FEET MUST REMAIN ON THE TRACTOR IN NORMAL DRIVING POSITION. DRIVERS MUST KEEP 1 HAND ON THE STEERING WHEEL AT ALL TIMES.
7. ALL DRIVERS MUST WEAR HELMETS AND ARE TO BE BUCKLED.

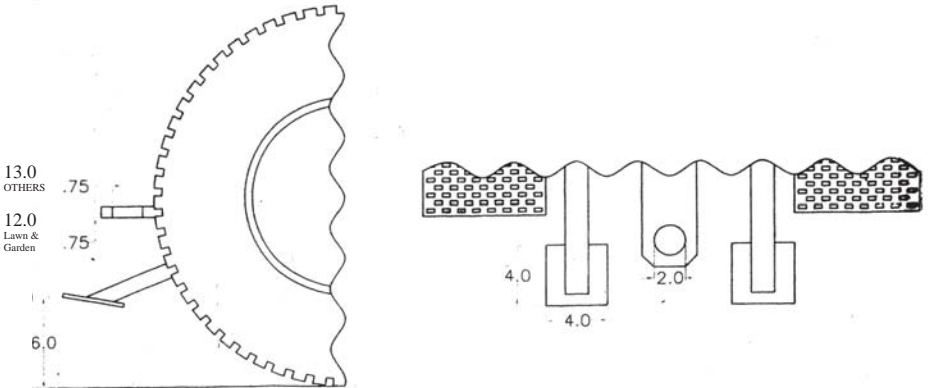

## **STOCK LAWN & GARDEN TRACTOR CLASS**

1. WEIGHT CLASSES TO BE 1100 AND 1400 LB.
2. STOCK TO BE ORIGINAL EQUIPMENT MANUFACTURE STOCK.
3. STOCK TRACTORS WILL HAVE STOCK HOOD, GRILL, MOTOR (TYPE AND SIZE), FENDERS IF SO EQUIPPED FROM THE MANUFACTURER.
4. ENGINE WILL BE FACTORY STOCK, AIR COOLED OR WATER COOLED WITH THREE CYLINDERS MAXIMUM. GOVERNOR MUST BE HOOKED UP AND WORKING AT ALL TIMES. MAX RPM 3850 RPM.
5. TRACTORS WILL USE A STOCK STYLE MUFFLER SYSTEM WITH NO STRAIGHT PIPES.
6. TRACTORS WILL USE RUBBER TIRES NOT TO EXCEED 34" IN HEIGHT & WILL HAVE WHEEL DIAMETER & TIRE SIZE & TYPE OF ORIGINAL EQUIPMENT FROM MANUFACTURER. TURF TIRES ONLY. NO CUT TIRES, DUAL WHEELS, TIRE STUDS, OR CHAINS PERMITTED.
7. OVERALL LENGTH OF THE TRACTOR NOT TO EXCEED 6 FEET MEASURED FROM THE CENTER OF THE REAR AXLE TO THE EXTREME FRONT OF THE WEIGHTS, WIDTH NOT TO EXCEED 6 FEET INCLUDING ALL WHEEL WEIGHTS.



8. ALL DRIVERS MUST WEAR HELMETS AND EYE PROTECTION WHEN PULLING.
9. DRIVERS IN STOCK LAWN AND GARDEN CLASS WILL BE ALLOWED TO PURCHASE A YEARLY COMPETITION MEMBERSHIP FOR \$25.00 (UNLESS DRIVERS CAN JOIN UNDER A FAMILY MEMBERSHIP). DRIVERS THAT PURCHASE THIS TYPE OF COMPETITION MEMBERSHIP UNDER THE STOCK LAWN & GARDEN TRACTOR CLASS WILL BE ISSUED A SPECIAL INSURANCE CARD. THIS SPECIAL INSURANCE CARD WILL BE GOOD FOR THE STOCK LAWN & GARDEN TRACTOR CLASS ONLY.
10. DRIVERS IN THE STOCK CLASS WHO ARE NOT MEMBERS MAY COMPETE WITH A ONE TIME MEMBERSHIP OF \$10.00 PER EVENT.
11. ALL WEIGHT RODS ON THE TIRES ARE NOT TO PROTRUDE MORE THAN 2 INCHES BEYOND THE LAST WEIGHT AT ANYTIME.
12. DRAW BARS WILL BE A FLAT DRAW BAR WITH A 2" OR LARGER HOLE. PULLING POINT MAY NOT BE MORE THAN 3/4" FROM THE BACK EDGE OF THE HITCHING DEVICE. THE HOOK WILL BE DROPPED IN FROM THE TOP OF THE BAR. DRAW BARS MUST BE RIGID IN ALL DIRECTIONS. HITCH HEIGHT TO BE MAXIMUM 12".
13. ALL TRACTORS WILL PULL IN TWO WHEEL DRIVE ONLY.
14. ALL TRACTORS SHALL HAVE WHEELIE PADS. PADS ARE TO BE 4"X4". MAXIMUM HEIGHT TO BE 6 INCHES. REAR OF PADS ARE TO MEASURE A MINIMUM OF 6 INCHES FROM OUTER REAR CIRCUMFERENCE OF THE TIRE. WHEELIE BARS TO BE TESTED AT A MAXIMUM WEIGHT AND STAMPED AS SUCH BY THE BOARD.
15. HITCH HEIGHT IS 12 INCHES MAXIMUM & IS MEASURED FROM THE TOP OF THE BAR
16. CLASS WILL BE OPEN TO ALL AGES 17 YEARS OLD AND YOUNGER FOR MSTTPA POINTS; OLDER MAY PULL BUT EXHIBITION ONLY.

## **NON-AUTOMOTIVE ENGINE POWERED TRACTOR CLASS**

1. WEIGHT CLASSES TO BE 1400 AND 1700 LB.
2. ALL WEIGHT RODS ON TIRES ARE NOT TO PROTRUDE MORE THAN 2 INCHES BEYOND THE LAST WEIGHT AT ANYTIME.
3. TRACTOR ENGINES:
  - A. ENGINE NOT TO EXCEED MORE THAN 1500 CC TOTAL, WITH NO MORE THAN 4 CYLINDERS.
  - B. IF DIESEL, NO MORE THAN 2 TURBOS.
4. TRACTOR WILL USE RUBBER TIRES NOT TO BE OVER 31' IN HEIGHT TIRES MAY BE CUT, MOLDED OR RE-STYLED IN ANY WAY, BUT NO ITEMS OR MATERIAL TO BE ADDED ON.
5. ALL TRACTORS WILL HAVE CLUTCH, BELT AND CHAIN GUARDS OF 1/8" OR MORE OF STEEL.
6. DRIVE TRAIN TO BE SUITABLY SHIELDED TO CONTAIN PARTS IN CASE OF BREAKAGE.

7. TRACTOR WILL USE A MUFFLER OR BAFFLED TUNED EXHAUST SYSTEM. ALL EXHAUST BEING DISCHARGED VERTICALLY, PLUS OR MINUS 10 DEGREES AT THE DIRECTORS DISCRETION.
8. NO PORTION OF ANY TRACTOR MAY EXCEED 8 FT FORWARD OF THE CENTER OF THE REAR WHEEL, NOR WILL IT EXCEED 6 FEET MAXIMUM WIDTH.
9. KILL SWITCHES ARE REQUIRED ON ALL TRACTORS, TO HAVE A 2 INCH RING MOUNTED IN THE REAR OF THE TRACTOR.
10. TRACTORS WILL HAVE FENDERS SUITABLE FOR PROTECTING THE DRIVER.
11. TRACTORS WILL BE EQUIPPED WITH A 2-1/2 LB. CLASS A.B. FIRE EXTINGUISHER
12. HITCH HEIGHT TO BE 13 INCH.
13. BACK UP LIGHT AND NEUTRAL SAFETY SWITCH NEEDED.
14. DRAW BARS WILL BE A FLAT DRAW BAR WITH A 2 INCH OR LARGER HOLE. PULLING POINT MAY NOT BE MORE THAN 3/4 FROM THE BACK EDGE OF THE HITCHING DEVICE. THE HOOK WILL BE DROPPED IN FROM THE TOP OF THE BAR. DRAW BARS MUST BE RIGID IN ALL DIRECTIONS.
15. ALL TRACTORS 2 WHEEL DRIVE ONLY.
16. ALL TRACTORS SHALL HAVE WHEELIE PADS. PADS ARE TO BE 4"X4" MAXIMUM HEIGHT TO BE 6 INCHES. REAR OF PADS ARE TO MEASURE MINIMUM OF 6 INCHES FROM OUTER REAR CIRCUMFERENCE OF THE TIRE. WHEELIE BARS TO BE TESTED AT A MAXIMUM WEIGHT AND STAMPED AS SUCH BY THE BOARD.

## **4 CYLINDER MINI MODIFIED TRACTOR CLASS**

1. WEIGHT CLASSES TO BE 1650 AND 1800 LB.
2. MUST BE AUTOMOTIVE WATER OR AIR COOLED, 4 CYLINDER 4 STROKE ENGINE. YOU MUST START WITH AN ENGINE NO MORE THAN 2500 CC OR 153 CI. YOU MAY DO ANYTHING YOU WISH INSIDE THE ENGINE.
3. YOU MAY USE ANY INTAKE MANIFOLD BUT CARBURETION IS LIMITED TO A MAXIMUM OF 500 CFM OF ANY COMBINATION, NATURALLY ASPIRATED, NON INJECTED.
4. ENGINE AND FIRST TRANSMISSION MUST BE COMPATIBLE.
5. ENGINES WITH STOCK INTAKE MANIFOLD AND CARBURETOR MUST BE EQUIPPED WITH A 3/16 THICK STEEL BELL HOUSING SAFETY SHIELD. IT MUST BE A 180 DEGREE DESIGN TO THE BOTTOM OF THE FLYWHEEL AND SECURELY ATTACHED TO THE TRACTOR, STARTING ONE INCH AHEAD OF THE FLYWHEEL OR AGAINST THE FACE OF THE ENGINE BLOCK AND BE A MINIMUM OF 6 INCHES WIDE OR THIS AREA MUST BE COVERED WITH APPROVED SF1 SAFETY BLANKET.

6. ENGINES WITH NON STOCK MANIFOLDS OR CARBURETORS MUST RUN ONE OF THE FOLLOWING:
  - a. AN APPROVED SF1 STEEL BELL HOUSING.
  - b. A BELL HOUSING COVERED WITH AN APPROVED SF1 SAFETY BLANKET
  - c. A STOCK BELL HOUSING COVERED WITH A FABRICATED SHIELD OF AT LEAST 3/16 STEEL STARTING AT THE REAR FACE OF THE ENGINE BLOCK AND EXTENDING AT LEAST REARWARD OF THE FRONT OF THE TRANSMISSION, IT IS TO BE OF A 360 DEGREE DESIGN AND ALSO TO INCLUDE THE FRONT OF THE BELL HOUSING THAT EXTENDS BELOW THE ENGINE BLOCK AS MUCH AS POSSIBLE. THE LOWER PORTION OF THE SHIELD MAY BE OF THE BOLT ON TYPE. THE INTENT OF THE SHIELD IS TO FULLY ENCASE THE BELL HOUSING AND TO CONTAIN A FAILURE IN THE AREA.
7. ALL AUTOMATIC TRANSMISSIONS MUST BE COVERED WITH AN APPROVED SAFETY BLANKET (BLANKET MUST MEET SEMA STANDARDS), OR BE COVERED WITH STEEL AS IN STANDARD TRANSMISSIONS SPECIFICATIONS.
8. ANY IGNITION SYSTEM ALLOWED. QUICK CHANGE REAR ENDS ALLOWED.
9. NO ALCOHOL FUEL ALLOWED.
10. ALL U JOINTS AND DRIVE SHAFTS MUST HAVE 360 DEGREE DESIGN SHIELDING MADE OF 1/8 STEEL. ALL FANS AND BELTS MUST BE COVERED BY 1/16 STEEL SHIELDING 360 DEGREES. (SEE DRIVELINE SHIELDING #1).
11. HARMONIC BALANCER SHALL BE SOLID STEEL OR SHROUDED WITH 1/4 STEEL NO MORE THAN ONE INCH AWAY IN DIRECTION OF ROTATION, 360 DEGREES TO BE SECURELY FASTENED.
12. TIRES WILL NOT BE ANY LARGER THAN 31 INCHES HIGH. NO DUAL WHEELS. ALL TRACTORS WILL PULL IN 2 WHEEL DRIVE.
13. ALL TRACTORS MUST MEET MINI SPECIFICATIONS ON FOLLOWING:
  - a. IGNITION KILL SWITCHES.
  - b. SAFETY SPECIFICATIONS.
  - c. EXHAUST SYSTEM.
  - d. CLUTCHES, FLYWHEELS, AND AUTOMATICS #2 AND #3 ONLY.
  - e. ENGINE SIDE SHIELDS (RULES #2 & #3 - ENGINES);
14. ALL TRACTORS WILL HAVE FENDERS SUITABLE FOR PROTECTING THE DRIVER.

15. HITCH HEIGHT IS 13 INCHES. AT THE HITCH POINT:
  - a. DRAW BAR MUST BE HORIZONTAL.
  - b. MUST HAVE A 2' OR LARGER HOLE.
  - c. MINIMUM 3/4 FROM PULLING POINT TO EDGE OF THE HITCHING DEVICE.
  - d. MINIMUM 3/4 THICK STEEL AT THE HOOKING POINT. ANY STEEL TUBING USED IN THE HITCH MUST HAVE A MINIMUM OF .160 WALL THICKNESS, ALL OTHER STEEL MUST BE MINIMUM .250. THE HITCH MUST BE RIGID IN ALL DIRECTIONS, NOT HAVING MORE THAN 1/2 PLAY.
  - e. NO PORTION OF VEHICLE MAY INTERFERE WITH SLED, CHAIN, OR HOOK DURING A PULL OR WHILE BEING HOOKED OR UNHOOKED.
  - f. DRAW BARS TO HAVE NO PROVISIONS TO BE MADE SHORTER THAN 6" FROM CENTER OF REAR AXLE.
  - g. DRAW BARS AND WHEELIE BARS ARE NOT TO BE CONNECTED.
16. ALL TRACTORS SHALL HAVE WHEELIE PADS. PADS ARE TO BE 4"X4". MAXIMUM HEIGHT TO BE 6 INCHES. REAR OF PADS ARE TO MEASURE A MINIMUM OF 6 INCHES FROM OUTER REAR CIRCUMFERENCE OF THE TIRE. WHEELIE BARS TO BE TESTED AT A MAXIMUM WEIGHT AND STAMPED AS SUCH BY THE BOARD.
17. NO PORTION OF ANY TRACTOR MAY EXCEED 8 FEET FORWARD OF THE CENTER OF THE REAR WHEEL. NOR WILL IT EXCEED 6 FEET MAXIMUM IN WIDTH.

## **MODIFIED LAWN & GARDEN TRACTOR CLASS**

1. WEIGHT CLASSES TO BE 1100 AND 1400 LB.
2. OVERALL LENGTH OF THE TRACTOR NOT TO EXCEED 6 FEET MEASURED FROM THE CENTER ON THE REAR AXLE TO THE EXTREME FRONT OF THE WEIGHTS. WIDTH NOT TO EXCEED 6 FEET INCLUDING ALL WHEEL WEIGHTS.
3. ALL DRIVERS MUST WEAR HELMETS AND EYE PROTECTION WHEN PULLING.
4. DRIVERS IN THE LAWN AND GARDEN CLASS WILL BE ALLOWED TO PURCHASE A YEARLY COMPETITION MEMBERSHIP FOR \$20.00 (UNLESS DRIVERS CAN JOIN UNDER A FAMILY MEMBERSHIP). DRIVERS THAT PURCHASE THIS TYPE OF COMPETITION MEMBERSHIP UNDER THE LAWN & GARDEN TRACTOR CLASS WILL BE ISSUED A SPECIAL INSURANCE CARD. THIS SPECIAL INSURANCE CARD WILL BE GOOD FOR THE LAWN & GARDEN TRACTOR CLASS ONLY.
5. DRIVERS IN THE MODIFIED CLASS WHO ARE NOT MEMBERS MAY COMPETE WITH ONE-TIME MEMBERSHIP OF \$10.00 PER EVENT.

6. ALL WEIGHT RODS ON THE TIRES ARE NOT TO PROTRUDE MORE THAN 2 INCHES BEYOND THE LAST WEIGHT AT ANYTIME.
7. DRAW BARS WILL BE A FLAT DRAW BAR WITH A 2-INCH OR LARGER HOLE. PULLING POINT MAY NOT BE MORE THAN 3/4" FROM THE BACK EDGE OF THE HITCHING DEVICE. THE HOOK WILL BE DROPPED IN FROM THE TOP OF THE BAR. DRAW BARS MUST BE RIGID IN ALL DIRECTIONS.
8. ALL TRACTORS WILL PULL IN TWO-WHEEL DRIVE ONLY.
9. ALL TRACTORS SHALL HAVE WHEELIE PADS. PADS ARE TO BE 4"X4". MAXIMUM HEIGHT TO BE 6 INCHES. REAR OF PADS ARE TO MEASURE A MINIMUM OF 6 INCHES FROM THE OUTER REAR CIRCUMFERENCE OF THE TIRE. WHEELIE BARS TO BE TESTED AT A MAXIMUM WEIGHT AND STAMPED AS SUCH BY THE BOARD.
10. HITCH HEIGHT IS 12" MAXIMUM AND IS MEASURED FROM THE TOP OF THE BAR.
11. TRACTORS MUST BE IN STOCK IN APPEARANCE AND HAVE HOOD, TINWARE, AND FENDERS IN PLACE.
12. ENGINES MUST BE O.E.M. PRODUCED ENGINE OF LAWN & GARDEN STYLE. KOHLER, BRIGGS, TECUMSEH, ONAN, ETC. 1 OR 2 CYL., FOUR CYCLE.
13. DRIVE TRAIN, TRANSMISSION, AXLE, TRANSAXLE, ETC. MUST BE OF STOCK APPEARANCE. NO EXPOSED ROTATING PARTS. " (SHIELDING REQUIRED)".
14. MUST USE A STOCK TYPE CARBURETOR: FLOAT BOWL STYLE, UNLESS IT IS PROVEN THAT THE ENGINE FOR THAT TRACTOR CAME WITH ANOTHER STYLE. GASOLINE OR DIESEL FUEL ONLY. NO ALCOHOL FUEL ALLOWED.
15. EXHAUST - IF MUFFLER IS NOT USED, MUST DISCHARGE VERTICAL ABOVE THE G ENGINE. HOOD MAY BE MODIFIED TO ACCEPT EXHAUST PIPES. (NO RAIN CAPS WHILE PULLING.) WITHIN 10 DEGREES OF PLUMB.
16. IF ENGINE IS NOT GOVERNED, IT MUST HAVE A DEADMAN THROTTLE CONTROL.
17. MAX TIRE SIZE 26 X 12:00 X 12. TIRE ALTERATION ALLOWED. NO CHAINS, DUAL TIRES, TIRE STUDS ALLOWED. 34" HIGH BUT NARROW TIRES THAT CAME STANDARD ON SOME MODELS WILL BE ALLOWED ON TECHMAN APPROVAL ONLY.
18. OPEN TO AGES 17 YEARS OLD OR YOUNGER FOR MSTTPA; OLDER MAY PULL BUT FOR THE EXHIBITION ONLY.
19. IF PRESIDING OFFICIAL AND TECH OFFICIAL FEEL A VEHICLE IS UNSAFE, THEY HAVE THE RIGHT NOT TO ALLOW VEHICLE TO PULL

## **SEMI TRUCK RULES**

1. TWIN-SCREW DIESEL SEMI TRACTOR WITH PRODUCTION COMMERCIAL ENGINES, MANUAL TRANSMISSIONS AND REAR ENDS ONLY. (MUST BE OVER THE ROAD TYPE).
2. HITCH HEIGHT TO BE 18", MINIMUM OF A 3" OPENING.
3. TIRES MAXIMUM SIZE 11-24.5 OR 1100-22", NOT TO BE CUT. NO MODIFIED TIRES.
4. ALL REAR AXLES SHALL BE CHAINED OR FASTENED TO PROHIBIT HITCH HEIGHT RISE.
5. 20,000 LB. MAXIMUM WEIGHT. ADDED WEIGHT CANNOT EXTEND BACK MORE THAN 50" FROM CENTER OF REAR AXLE. WEIGHT OR HITCH NOT TO INTERFERE WITH SLED HOOK-UP. NO MOVEABLE WEIGHTS.
6. ALL TRUCKS TO BE INSPECTED BY SAFETY OR TECH COMMITTEE.

## **FIFTH WHEEL**

7. THE FIFTH WHEEL MAY BE MOVED FORWARD OF THE CENTER OF THE TRUNION NO MORE THAN 24" IT MAY MOVE TO THE FURTHEST AVAILABLE POSITION. FIFTH WHEELS MAY BE WELDED AND NON-MOVABLE.

## **TIRES**

8. ALL TIRES MUST BE ROAD USE APPROVED TIRES. DUAL WHEEL AND DUAL TIRES MUST BE USED ON THE REAR AXLES. NO FLotation, BAR OR SINGLE TIRES PERMITTED ON THE REAR AXLES. NO CHAINS OR CABLES PERMITTED. NO CUTTING OF TIRES PERMITTED, MAXIMUM TIRE SIZE LIMITED TO 11.24.5 (22" WHEEL RIM).

## **VEHICLE**

9. IF ORIGINAL VEHICLE HAS DOORS, THERE MUST BE ONE AND CLOSED.
10. TRUCK MUST RUN WITH HOOD AND FENDERS ON.
11. BODY MODIFICATIONS MAY BE MADE TO THE TRUCK AS LONG AS THEY MEET SAFETY & TECH REGULATIONS AND ARE PRESENTABLE. ANY UNSAFE APPEARING VEHICLE CAN BE RE-INSPECTED BY TECHNICAL COMMITTEE AND BE DISQUALIFIED FROM COMPETITION UNLESS UNSAFE CONDITION IS CORRECTED. IF UNSAFE CONDITION IS CORRECTED, VEHICLE MUST BE RE-INSPECTED BEFORE COMPETING.
12. ALL VEHICLES MUST HAVE A SUITABLE FIREWALL BETWEEN ENGINE AND THE DRIVER. IF SUITABLE FIREWALL IS NOT IN PLACE, TECHNICAL COMMITTEE WILL DETERMINE WHETHER VEHICLE CAN COMPETE. IF VEHICLE IS PERMITTED TO COMPETE, DRIVER MUST WEAR COMPLETE N.H.R.A. APPROVED FIRE SUIT, INCLUDING HELMET AND BOOTS, DURING COMPETITION.

13. ALL BATTERIES MUST BE MOUNTED OUTSIDE THE CAB AND BE SECURED.
14. ALL VEHICLES MUST HAVE WORKABLE BRAKES.
15. EXHAUST MUST DISCHARGE UPWARD ON ALL VEHICLES.
16. FIRE EXTINGUISHERS ARE REQUIRED AND MUST BE OPERABLE. FIRE EXTINGUISHER MUST BE WITHIN EASY REACH OF DRIVER.
17. ALL VEHICLES MUST BE IN NEUTRAL WHILE BEING HITCHED OR UNHITCHED. DRIVER'S HANDS MUST BE OFF STEERING WHEEL AND GEAR SHIFTER AND VISIBLE TO TRACK CREW.
18. VEHICLES MUST BE OPERATED IN A SAFE MANNER AT ALL TIMES. DRIVER MUST HAVE COMPLETE CONTROL OF VEHICLE AT ALL TIMES.
19. NO FOREIGN MATERIALS MAY BE INTENTIONALLY SPREAD OR SPILLED ON THE TRACK BY THE VEHICLE COMPETING.
20. ALL PULLS WILL START WITH A TIGHT CHAIN; NO JERKING OF CHAIN OR SLED WILL BE PERMITTED.
21. DRIVERS MUST REMAIN SEATED DURING THE PULL AND REMAIN IN THE CAB OF VEHICLE UNTIL TRACK OFFICIALS PERMITS DRIVER TO LEAVE CAB. (UNLESS IN FIRE EMERGENCY).
22. OBVIOUS USE OF INTOXICANTS OR STIMULANTS WILL BE CAUSE FOR DISQUALIFICATION OF DRIVER & VEHICLE.
23. VEHICLE CREW MEMBERS WILL ABIDE BY THE SAME RULES AS THE DRIVER AND ARE SUBJECT TO THE SAME DISCIPLINES. CREW MEMBERS WILL PERFORM THEIR DUTIES IN A SAFE AND ORDERLY MANNER AT ALL TIMES. CREW MEMBERS WILL NOT APPROACH VEHICLE DURING OR AFTER PULL UNLESS PERMITTED BY TRACK OFFICIALS. IN THE EVENT OF AN EMERGENCY, CREW MEMBERS WILL NOT INTERFERE WITH THE TRACK OFFICIALS IN THE PERFORMANCE OF THEIR DUTIES.
24. NON-CREW MEMBERS MUST REMAIN AWAY FROM THE TRACK AND VEHICLE DURING AND AFTER COMPETITION, OR DURING AN EMERGENCY.
25. DRIVER MUST BE QUALIFIED TO DRIVE AND MUST DEMONSTRATE ABILITY TO HANDLE VEHICLE TO TECHNICAL COMMITTEE. NO DRIVERS UNDER THE AGE OF 16 WILL BE PERMITTED TO COMPETE.

## **WEIGHTS OR ADDED BALLAST**

26. WEIGHT CANNOT EXTEND MORE THAN 50" FROM THE CENTER OF THE REAR AXLE (WEIGHT INCLUDED) BACKWARD.
27. WEIGHT CANNOT EXTEND MORE THAN 24" FROM THE FURTHEST POINT FORWARD (BUMPER, GRILLE IF NO BUMPER).

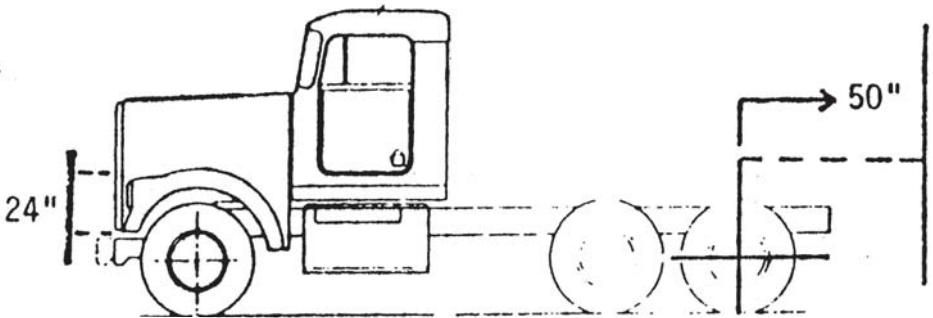

28. WEIGHT MUST BE SECURELY MOUNTED. ANY WEIGHT THAT HITS THE TRACK DURING COMPETITION WILL BE GROUNDS FOR DISQUALIFICATION AND THAT PULL TO BE STOPPED BY FLAG MAN.
29. WEIGHT MUST NOT INTERFERE WITH THE HOOKUP OF THE HITCH OR THE HOOKING OF THE SLED TO THE HITCH.
30. NO MOVABLE WEIGHTS PERMITTED DURING COMPETITION (SUCH AS HYDRAULIC-CONTROLLED WEIGHT RACKS OR BOXES).

## **CHAINING OF AXLES**

31. ALL TRUCKS WILL BE CHAINED DOWN EITHER AIR RIDE OR LEAF SPRING SUSPENSIONS.
32. THE CHAINING SHALL BE OF THE REAR DRIVE AXLE ONLY, ON BOTH SIDES OF THE AXLE, TO THE FRAME, WITH CHAIN CIRCLING THE FRAME SO THAT THE HITCH CANNOT BE RAISED.
  - A. TURNBUCKLING THE REAR DRIVE AXLE DOWN SO THAT IT WILL NOT MOVE UPWARD IS CONSIDERED CHAINING.
  - B. PINNING THE REAR DRIVE AXLE DOWN SO THAT IT WILL NOT MOVE UPWARD IS CONSIDERED CHAINING.
  - C. IF THE TRUCK IS A SINGLE REAR DRIVE, THE DRIVE AXLE WILL BE CHAINED WHETHER IT IS FRONT OR REAR AXLE. EXAMPLE: ONE AXLE IS AN AIR TAG.
  - D. CHAINING UP ANY AXLE IS NOT PERMITTED.



## **AXLES**

33. ONLY TANDEM AXLE SEMI-TRUCKS WILL BE PERMITTED TO COMPETE. NO SINGLE AXLE TRUCKS. NO DUMP TRUCKS. NO SPECIALTY TRUCKS (WELL DRILLING, WRECKERS, BOOM TRUCKS OR ROLL OFF TRUCKS ETC.) WILL BE PERMITTED TO COMPETE.
34. NO TRI-AXLE TRUCKS WILL BE PERMITTED TO COMPETE.
35. NO VEHICLE MAY COMPETE WHICH HAS CHAINED, PINNED OR IN ANY WAY RAISED THE REAR AXLE OFF THE GROUND. ALL AXLES MUST BE ON THE GROUND TO COMPETE, WHETHER DRIVE AXLES OR NOT.

## **POWER TRAIN**

36. ONE PRODUCTION-AVAILABLE COMMERCIAL TRUCK ENGINE ONLY WILL BE PERMITTED. NO MULTI-ENGINES. NO NON-COMMERCIAL TRUCK ENGINES (CAR, PICKUP TRUCKS, MILITARY, AIRCRAFT, SPECIALTY ENGINES SUCH AS RODECK, BLACK, ARIAS, ETC.) PERMITTED.

## **TURBO**

37. IF AN ENGINE IS EQUIPPED WITH TURBOCHARGERS, THE TOTAL NUMBER OF TURBOCHARGERS AVAILABLE FOR THAT ENGINE WILL BE PERMITTED. NO ADDITIONAL TURBOCHARGERS WILL BE ALLOWED.
38. TRANSMISSION AND REAR ENDS MUST BE COMMERCIAL SEMI-TRUCK FACTORY COMPONENTS. NO SPECIALTY TRANSMISSIONS OR REAR ENDS PERMITTED. AUTOMATIC TRANSMISSION PERMITTED.



# WEIGHT CLASSES

- Street Stock 7,000 lbs.
- Super Stock 6,200 lbs.
- 3.0 Diesel Trucks 8,000 lbs.
- 2.5 Diesel Trucks 8,500 lbs.
- Modified 6,200 lbs.
- Big Rig 20,000 lbs.

# CLAY

GMC-CHEVROLET  
OF LINCOLN

*HOME OF THE  
ALL AMERICAN TRUCKER!*

---

**470 MAIN ST. • LINCOLN, ME**  
**(207) 794-6191 • (207) 794-6503**



**GMC**®  
WE ARE PROFESSIONAL GRADE.®

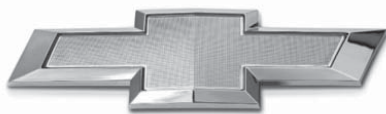

**FIND NEW ROADS™**